



DEPUIS 1978 A VOTRE SERVICE

BOSI
La forge Artistique

Éléments en fer forgé

pour grilles, portails et garde-corps

Créateur et Fabricant **Français** 

N°12 / 2024

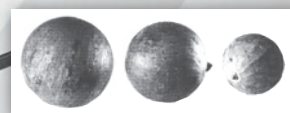

www.bosi-laforgeartistique.com



**Qualité,
Disponibilité,
Service...**



Usine



M. Franco BOSI forgeron, créa son entreprise en 1978 : **BOSI "La Forge Artistique"** dans le sud de la France.

Depuis, lui et son fils Michel, continuent de fabriquer à l'ancienne leurs propres modèles, en élargissant régulièrement leur gamme. Ils créent leurs modèles en respectant le travail d'autrefois ainsi que le style de nos régions. Aujourd'hui, c'est grâce à une équipe de forgerons professionnels, une usine de production à la fois traditionnelle et moderne ainsi qu'un important dépôt que **BOSI "La Forge Artistique"** peut satisfaire rapidement ses clients à des prix très compétitifs.







Dépôt

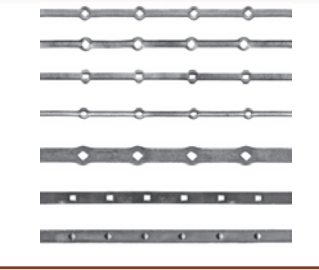
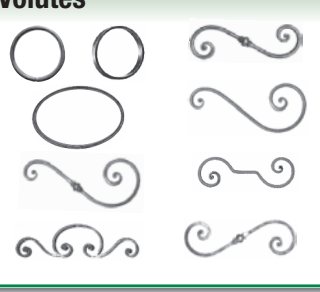
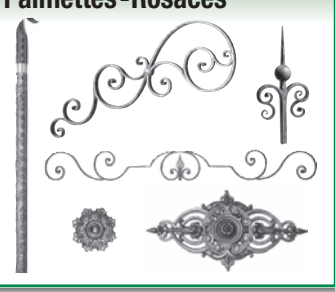

Entrepôt de stockage 1500 m²
50.000 articles en stock

Sommaire

Barreaux de balcon 4 à 21 	Barreaux et Panneaux décoratifs 22 à 28 	Montants forts Caches - Boules 29 à 33 	Montants à trous poinçonnés et accessoires 34 à 37 
Crosses et Coudes 38 	Mains-courantes Aciers lisses et martelés 39 - 40 	Traverses 41 à 43 	Barreaux-Flèches Montants de clôture - Tôle fest. 44 à 55 
Anneaux - Ovaies Volutes 56 à 60 	Éléments pour Marquises et Tonnelles 61 - 62 	Éléments pour escalier colimaçon 63 	Éléments Portails Palmettes - Rosaces 64 à 67 
Accessoires pour Portes et Portails 68 à 73 	Serrures et Tubes Pré percés 74 à 76 	Décors Barreaux - Feuilles - Fleurs 77 - 78 	Platines acier Peinture Antirouille - Divers 79 à 81 
Garnitures Bagues acier - Caches 82 	Flèches forgées et estampées - Pommés de pin 83 - 84 	Boules pleines creuses - percées 85 	Accessoires laiton Boules de départ de rampe 86 - 87 



MARTELÉ
 ART. 15C-14-910
 H. 910-□14

MARTELÉ
 ART. 21-14-910
 H. 910-□14

LISSE
 ART. 21L-14-910
 H. 910-□14

MARTELÉ
 ART. 21D2-14-910
 H. 910-□14

LISSE
 ART. 21LD2-14-910
 H. 910-□14

MARTELÉ
 ART. 21-20-1000
 H. 1000-□20

LISSE
 ART. 21L-20-1000
 H. 1000-□20

ART. 21-14-1100
 H. 1100-□14

ART. 21L-14-1100
 H. 1100-□14

ART. 21-16-1300
 H. 1300-□16

ART. 21L-16-1300
 H. 1300-□16

ART. 21-20-1300
 H. 1300-□20

ART. 21L-20-1300
 H. 1300-□20

ART. 21-18-2000
 H. 2000-□18

ART. 21L-18-2000
 H. 2000-□18



barreau **15C-14-910** □ 14
 montant fort **MT15C-25-1200** □ 25
 boule **B4**
 crosse **S45**
 carré martelé **CM14-2000** H 2000



barreau **21-14-910** □ 14
 montant fort **MT21-25-1200** □ 25
 volute **V204M-14X6**
 platine **PLA** Ø 80
 boule de départ **B15** Ø 80
 carré martelé **CM14-2000** H 2000

Les côtes sont approximatives et données à titre indicatif.
 Les barreaux sont bruts à recouper et à redresser.

BARREAUX FORGÉS A CHAUD DANS LA MASSE DU FER

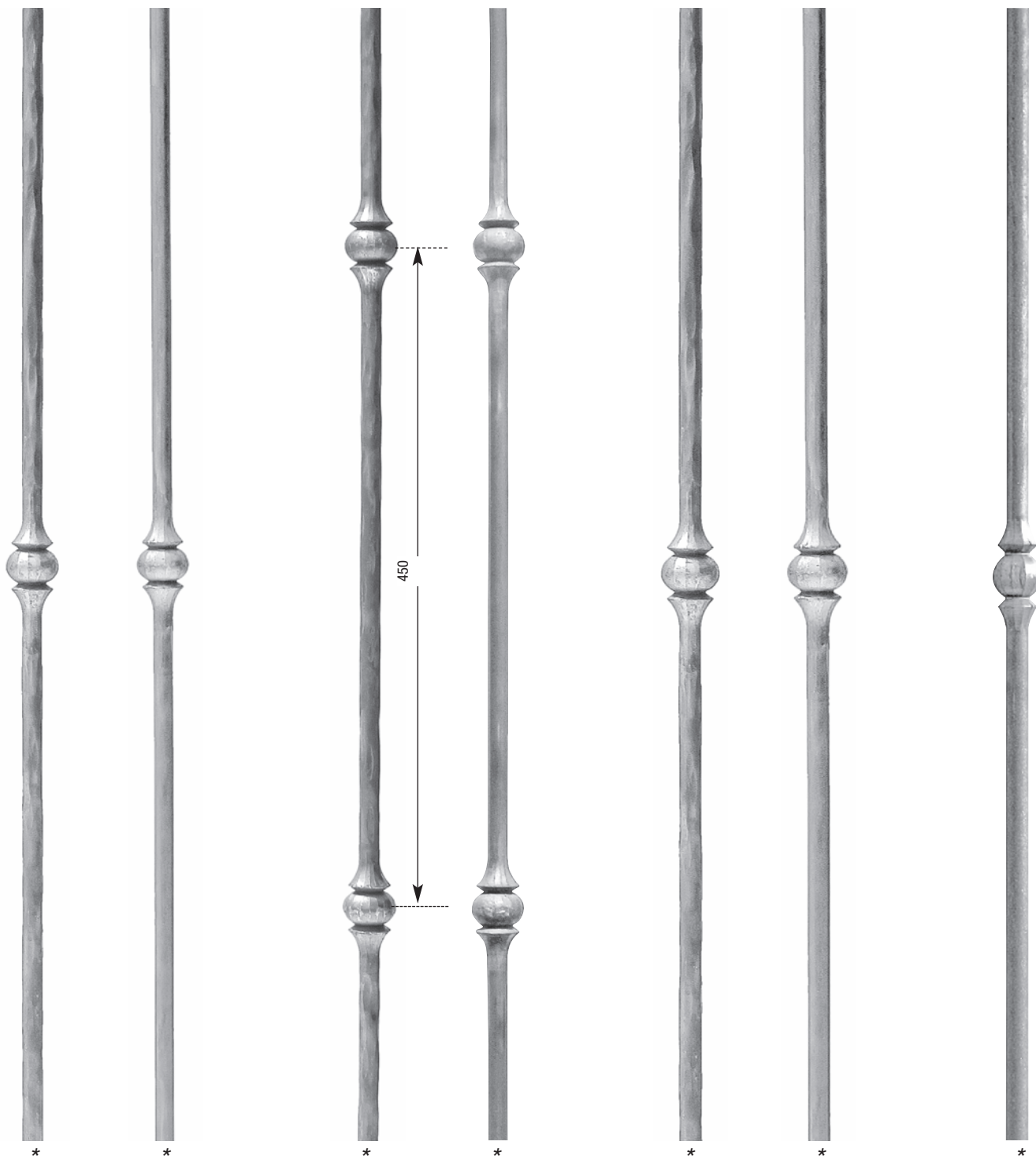

MARTELÉ	LISSE
ART. 15M-14-910 H. 910-Ø14	ART. 15L-14-910 H. 910-Ø14
ART. 15M-14-1100 H. 1100-Ø14	ART. 15L-14-1100 H. 1100-Ø14

MARTELÉ	LISSE
ART. 15MD2-14-910 H. 910-Ø14	ART. 15LD2-14-910 H. 910-Ø14

MARTELÉ	LISSE
ART. 15M-20-1000 H. 1000-Ø20	ART. 15L-20-1000 H. 1000-Ø20
ART. 15M-20-1300 H. 1300-Ø20	ART. 15L-20-1300 H. 1300-Ø20
	ART. 15L-20-2000 H. 2000-Ø20

LISSE
ART. 85L-14-910 H. 910-Ø14



barreau **15 MB-14-910** Ø 14
 montant fort **MT15C-25-1200** □ 25
 platine **PLA** Ø 80
 boule départ **B15** Ø 80
 carré martelé **CM14-2000** H 2000



barreau **15MB-14-910** Ø 14
 barreau **GR-14-910** Ø 14
 montant fort **MT15C-25-1200** □ 25
 boule **B4**
 volute **VOLS45G**
 crose **S45G**

Les côtes sont approximatives et données à titre indicatif. Les barreaux sont bruts à recouper et à redresser. *Modèle déposé



MARTELÉ	LISSE	MARTELÉ	LISSE	MARTELÉ	LISSE	MARTELÉ	MARTELÉ	MARTELÉ	MARTELÉ	LISSE
ART. CM14B-910 H. 910-□14	ART. CL14B-910 H. 910-□14	ART. RM14B-910 H. 910-Ø14	ART. RL14B-910 H. 910-Ø14	ART. 25-14-910 H. 910-□14	ART. 25L-14-910 H. 910-□14	ART. 5-14-910 H. 910-□14	ART. 23-14-910 H. 910-□14	ART. 39-14-910 H. 910-□14	ART. 38-14-910 H. 910-Ø14	
ART. CM14-1100 H. 1100-□14	ART. CL14-1100 H. 1100-□14	ART. RM14-1100 H. 1100-Ø14	ART. RL14-1100 H. 1100-Ø14							
ART. CM14-2000 H. 2000-□14	ART. CL14-2000 H. 2000-□14	ART. RM14-2000 H. 2000-Ø14	ART. RL14-2000 H. 2000-Ø14							



barreau **21-14-910** □ 14
 montant fort **MT21-25-1200** □ 25
 volute **V204M-14X6**
 platine **PLA** Ø 80
 boule départ **B15** Ø 80
 carré martelé **CM14-2000** H 2000



barreau **V6-14-910** □ 14
 barreau **30-14-910** □ 14
 montant fort **MT30-25** □ 25
 crosse **S45**
 carré martelé **CM14-2000** H 2000

Les côtes sont approximatives et données à titre indicatif.
Les barreaux sont bruts à recouper et à redresser.

BARREAUX FORGÉS A CHAUD DANS LA MASSE DU FER

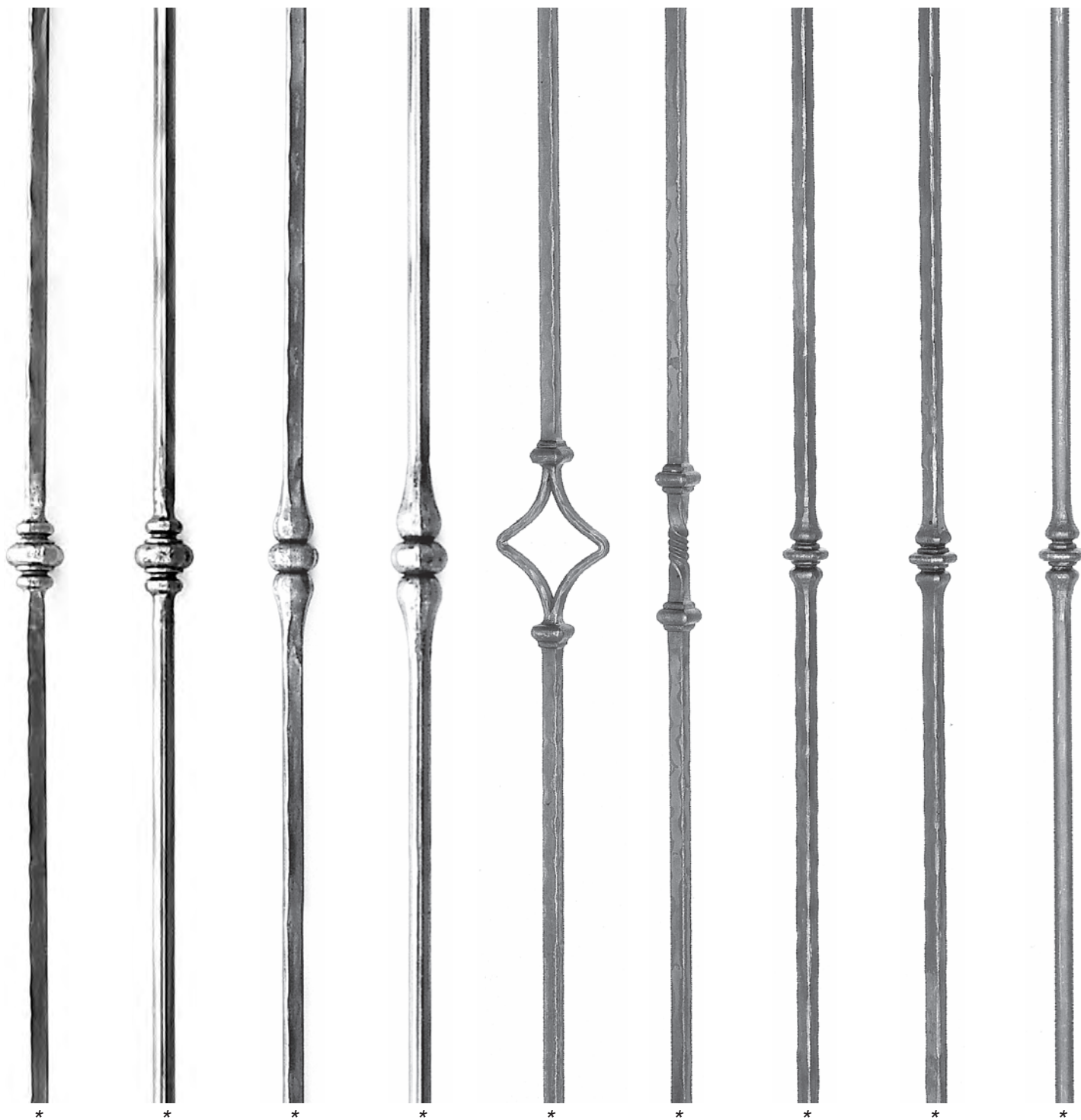

MARTELÉ	LISSE	MARTELÉ	LISSE	MARTELÉ	MARTELÉ	MARTELÉ	MARTELÉ	LISSE
ART. 51-14-910 H. 910-□14	ART. 50-14-910 H. 910-Ø14	ART. 53-14-910 H. 910-□14	ART. 52-14-910 H. 910-Ø14	ART. 29-14-910 H. 910-□14	ART. 30-14-910 H. 910-□14	ART. 32-14-910 H. 910-□14	ART. 33-14-910 H. 910-□14	ART. 31-14-910 H. 910-Ø14

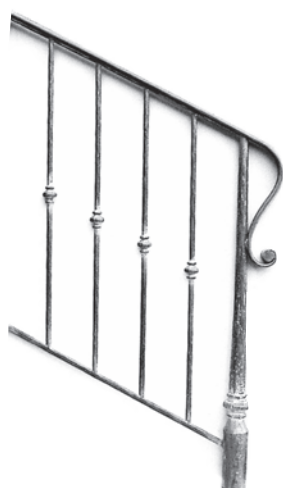

barreau 50-14-910 Ø 14
montant fort MT41-22-1200
crosse S45
carré martelé CL14-2000



barreau 15MB-14-910 Ø 14
barreau GR-14-910 Ø 14
montant fort MT15-25-1200 □ 25
boule B4
volute VD10
crosse S45G + VOL S45G

Les côtes sont approximatives et données à titre indicatif.
Les barreaux sont bruts à recouper et à redresser. *Modèle déposé

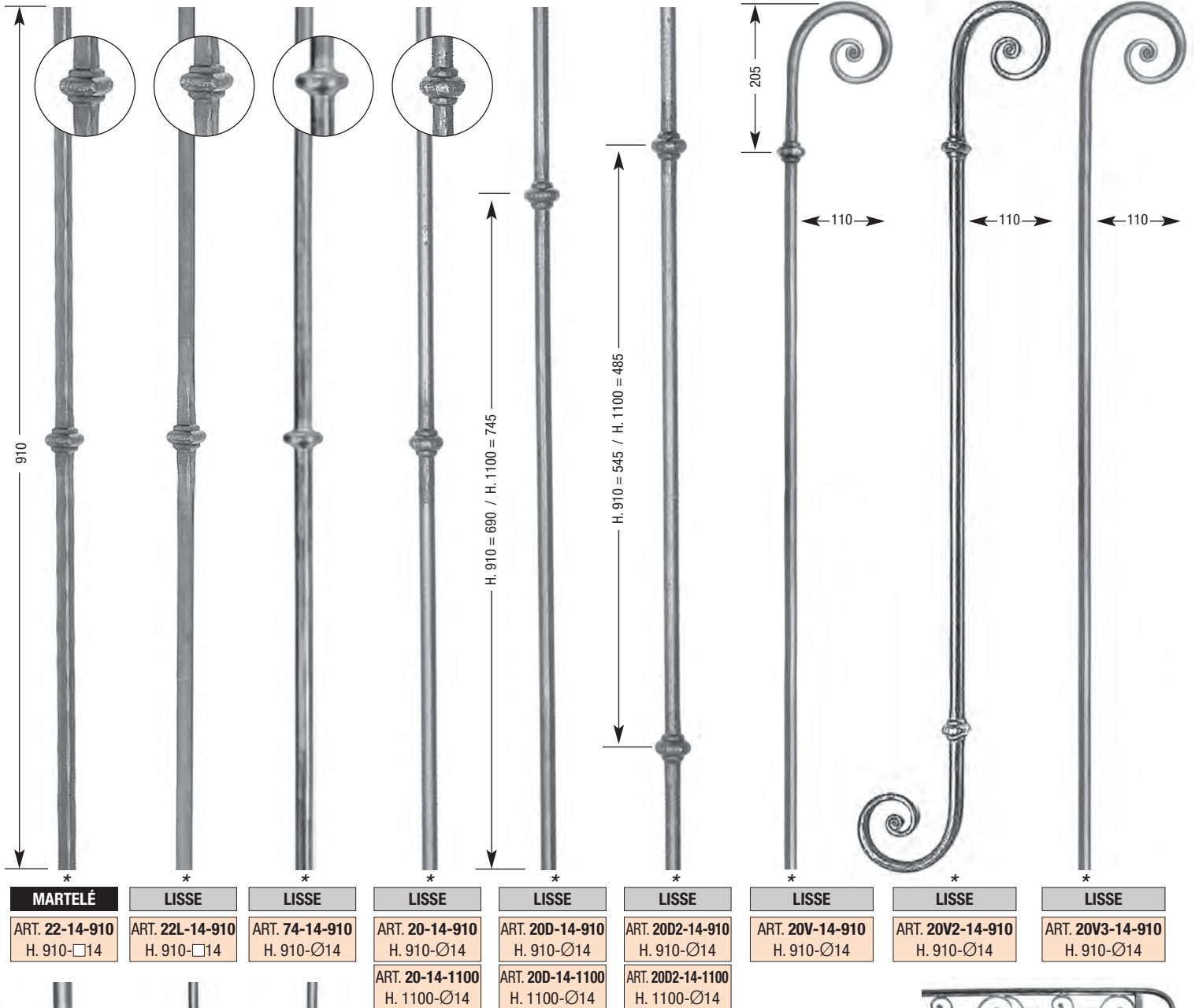

barreau	20-14-910	Ø 14
volute	V214L-14X6	
montant fort	MT22L-25-1200	□ 25
crosse	S45	
carré lisse	CL14-2000	H 2000



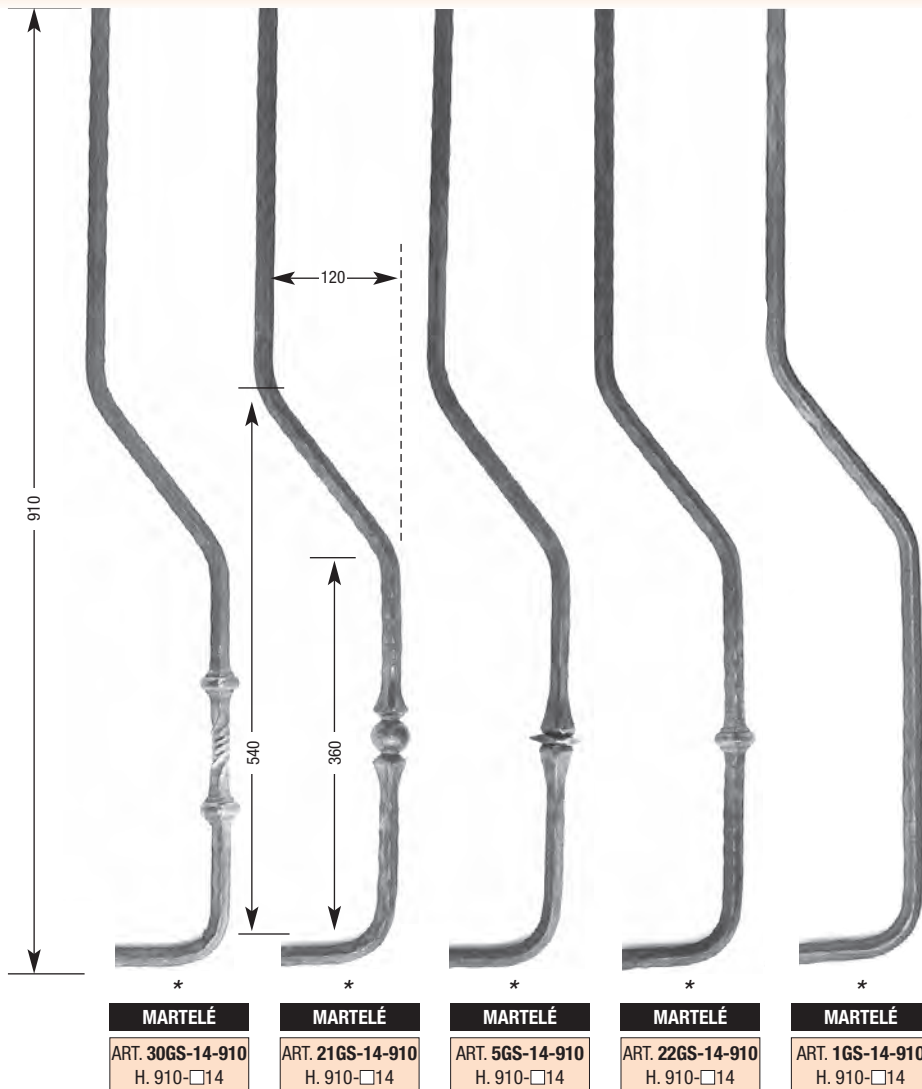

MARTELÉ
ART. 30GS-14-910
H. 910-□14

MARTELÉ
ART. 21GS-14-910
H. 910-□14

MARTELÉ
ART. 5GS-14-910
H. 910-□14

MARTELÉ
ART. 22GS-14-910
H. 910-□14

MARTELÉ
ART. 1GS-14-910
H. 910-□14

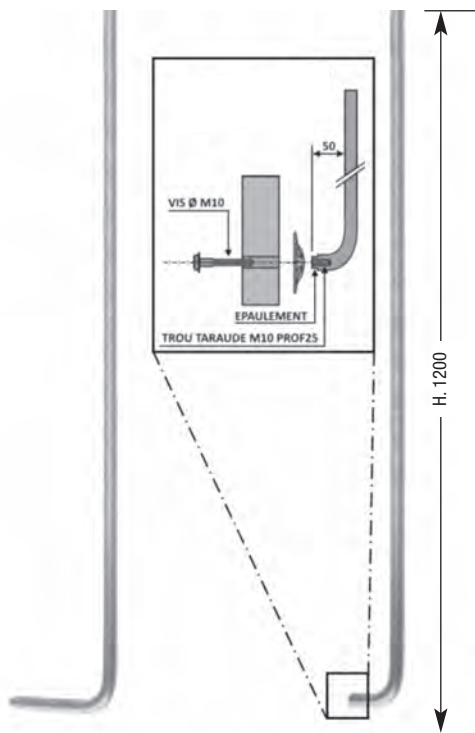

LISSE
ART. RL16C1
H. 1200-Ø16

LISSE
ART. RL16C2
H. 1200-Ø16
Taraudage M10

LISSE
ART. RL14C3
H. 1200-Ø14
2 trous Ø 6,5

Insert acier doux
Ø 8 mm



ART. F62-373
Ø 35 mm - H 102 mm
Insert Ø 8 mm
Trou Ø 16 mm

Insert acier doux
Ø 8 mm



ART. F62-374
Ø 35 mm - H 102 mm
Insert Ø 8 mm
Trou Ø 16 mm

ART. F62-375
L 60 mm - H 140 mm
Tige filetée 18
Trou Ø 16 mm



ART. F68-203
section 20x10 mm
Longueur : 175 mm

ART. F68-202
section 20x20 mm
Longueur : 175 mm

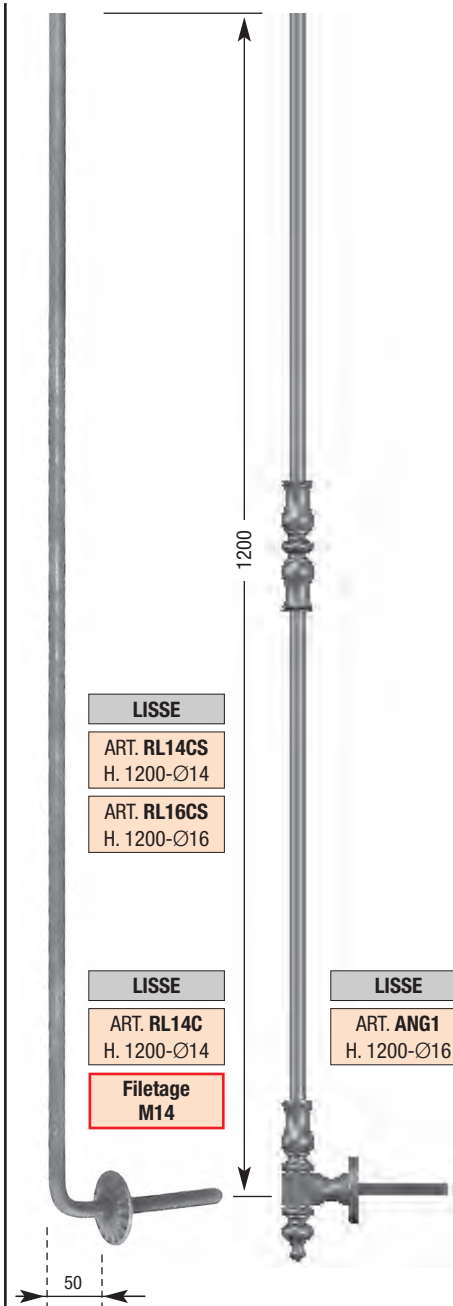

LISSE
ART. RL14CS
H. 1200-Ø14

LISSE
ART. RL16CS
H. 1200-Ø16

LISSE
ART. RL14C
H. 1200-Ø14

Filetage M14

LISSE
ART. ANG1
H. 1200-Ø16

ACIER



LISSE
ART. ANG2
120x30 - trou Ø16

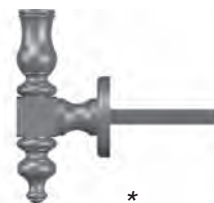

LISSE
ART. ANG3
145x70-trou Ø16
tige filetée M16

LAITON



LISSE
ART. AR78360
135x40 - trou Ø16



LISSE
ART. AR34300
135x95 - trou Ø16

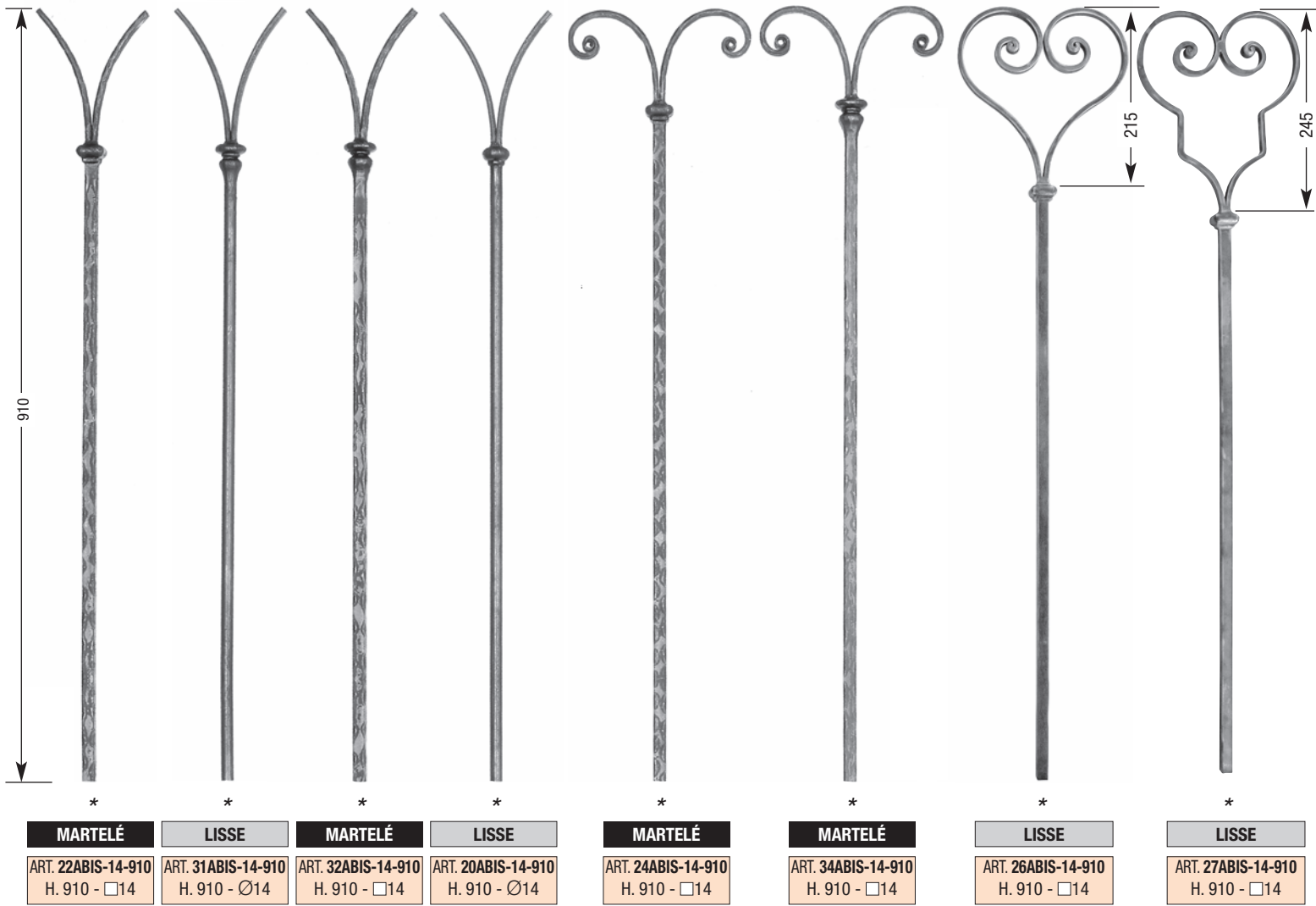

MARTELÉ	LISSE	MARTELÉ	LISSE	MARTELÉ	MARTELÉ	LISSE	LISSE
ART. 22ABIS-14-910 H. 910 - □14	ART. 31ABIS-14-910 H. 910 - Ø14	ART. 32ABIS-14-910 H. 910 - □14	ART. 20ABIS-14-910 H. 910 - Ø14	ART. 24ABIS-14-910 H. 910 - □14	ART. 34ABIS-14-910 H. 910 - □14	ART. 26ABIS-14-910 H. 910 - □14	ART. 27ABIS-14-910 H. 910 - □14

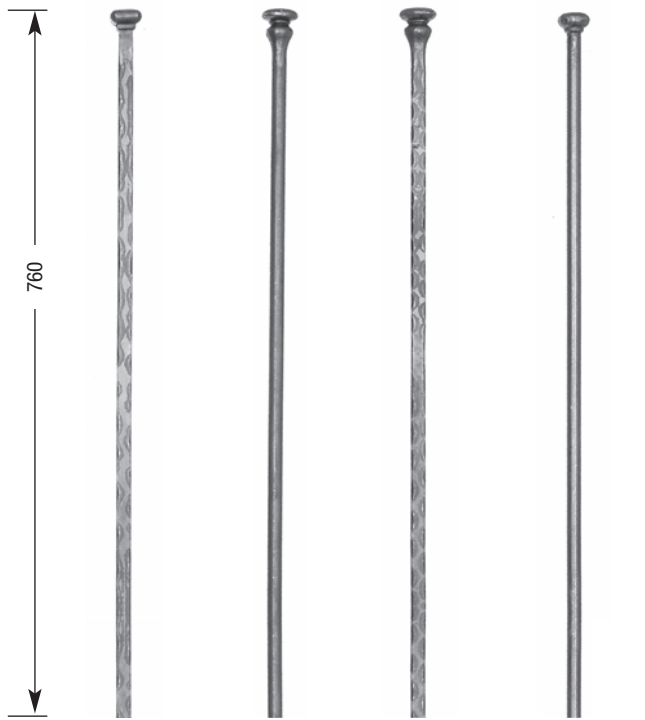

ART. A1M	MARTELÉ
ART. A1L	LISSE
□ 14 X 6	

ART. A2M	MARTELÉ
ART. A2L	LISSE
□ 14 X 6	



barreau	31ABIS-14-910	Ø 14	
montant fort	MT31-30-1200	Ø 30	
crosse	S45		
carré lisse	CL14-2000	H 2000	
barreau	34ABIS-14-910	□ 14	
montant fort	MT32M-25-1200	□ 25	
crosse	S45		
carré martelé	CM14-2000	H 2000	

MARTELÉ	LISSE	MARTELÉ	LISSE
ART. 22A-14-760 H. 760 - □14	ART. 31A-14-760 H. 760 - Ø14	ART. 32A-14-760 H. 760 - □14	ART. 20A-14-760 H. 760 - Ø14

BARREAUX ET MONTANTS FORGÉS **modèles déposés*

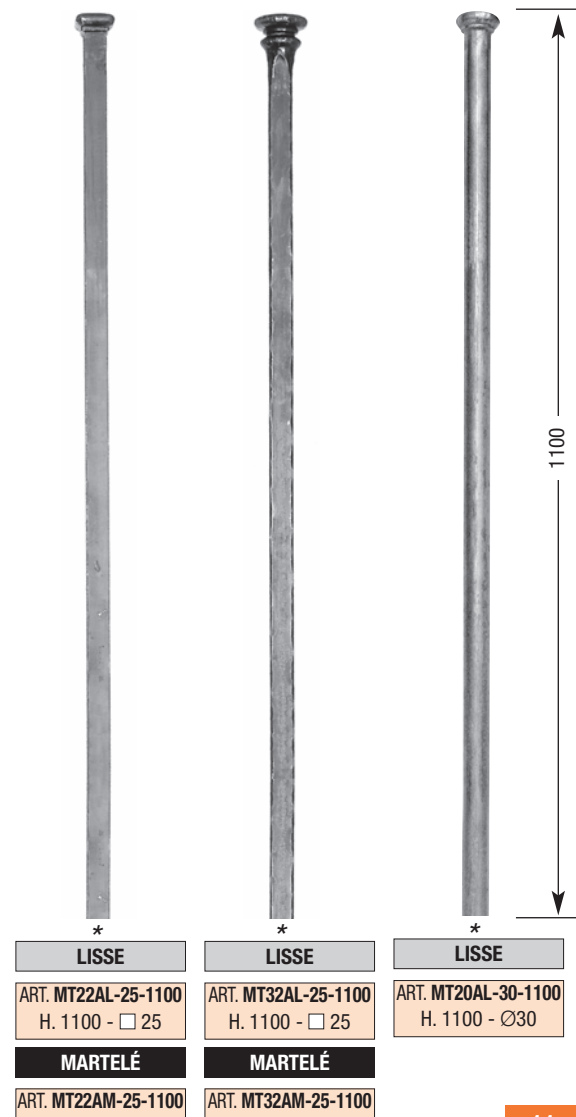
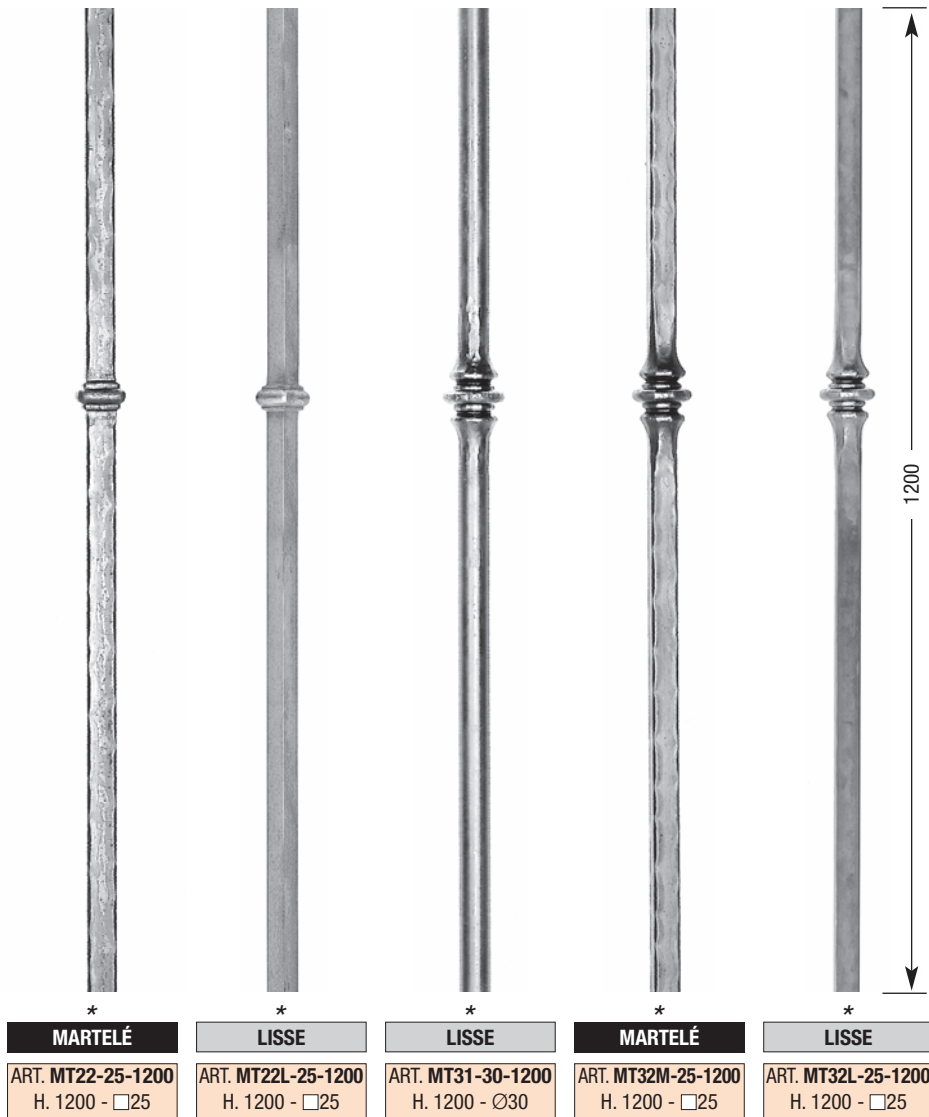
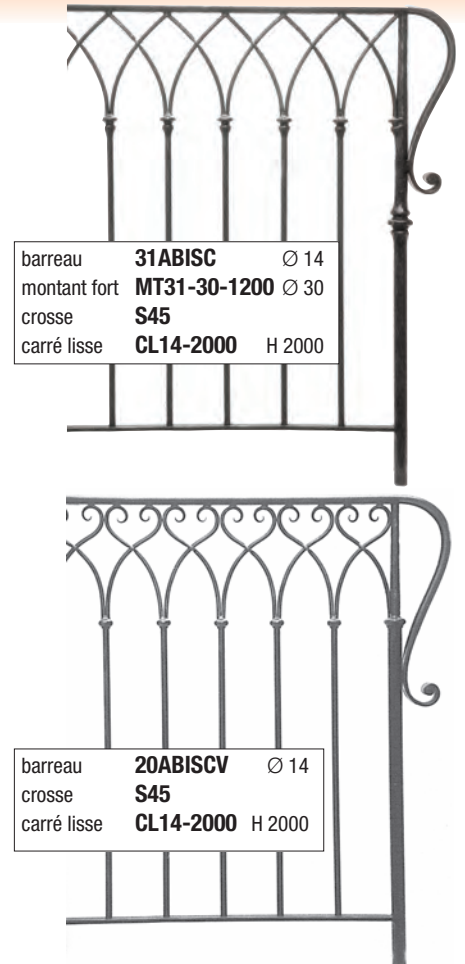
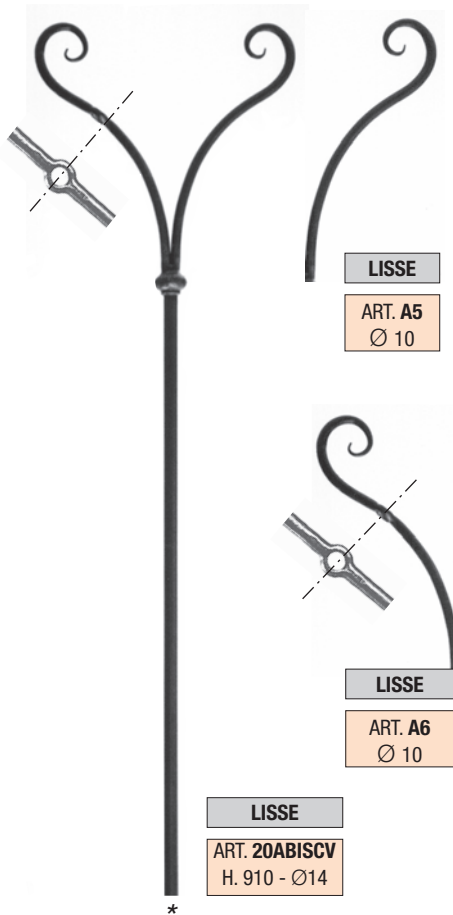
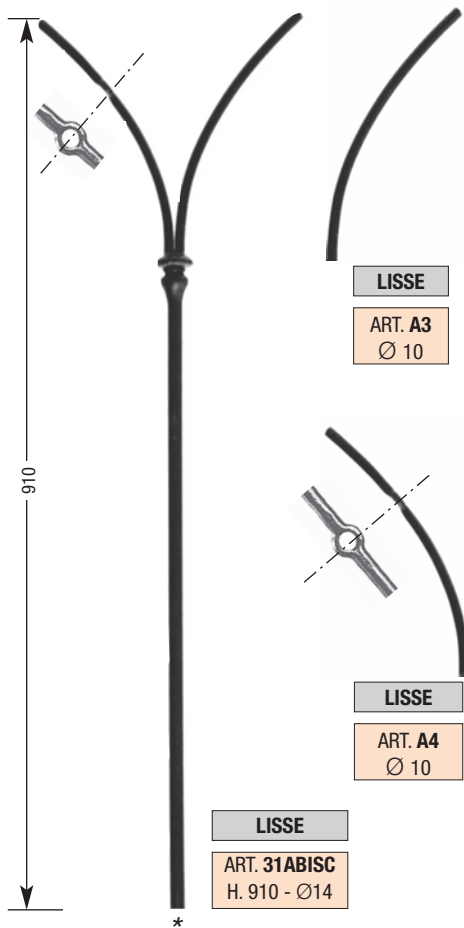

BARREAUX FORGÉS A CHAUD DANS LA MASSE DU FER COMPTEMPORAINS



*
LISSE
 ART. 70-14-910
 H. 910 - Ø14

*
LISSE
 ART. 71-14-910
 H. 910 - □14

*
LISSE
 ART. 72-14-910
 H. 910 - Ø14

*
LISSE
 ART. 73-14-910
 H. 910 - Ø14

*
LISSE
 ART. 80L-14-910
 H. 910 - Ø14

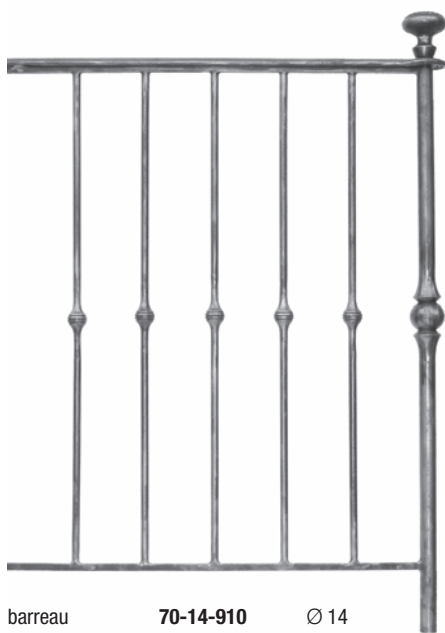

barreau **70-14-910** Ø 14
 montant fort **MT15L-30-1200** Ø 30
 platine **PLA** Ø 80
 boule de départ **B16** Ø 80
 carré lisse **CL14-2000** H 2000



barreau **80L-14-910** Ø 14
 montant fort **MT80L-30-1200** Ø 30
 volute **V104L-14X6** □ 14x6
 crosse **S45**
 carré lisse **CL14-2000** H 2000

BARREAUX FORGÉS A CHAUD



MARTELÉ
ART. CP7
□12



barreau **16-12-910** □ 12
montant fort **MT51-25-1200** □ 25
crosse **S45**
carré martelé **CM14-200** H 2000

BARREAUX FORGÉS A CHAUD DANS LA MASSE DU FER

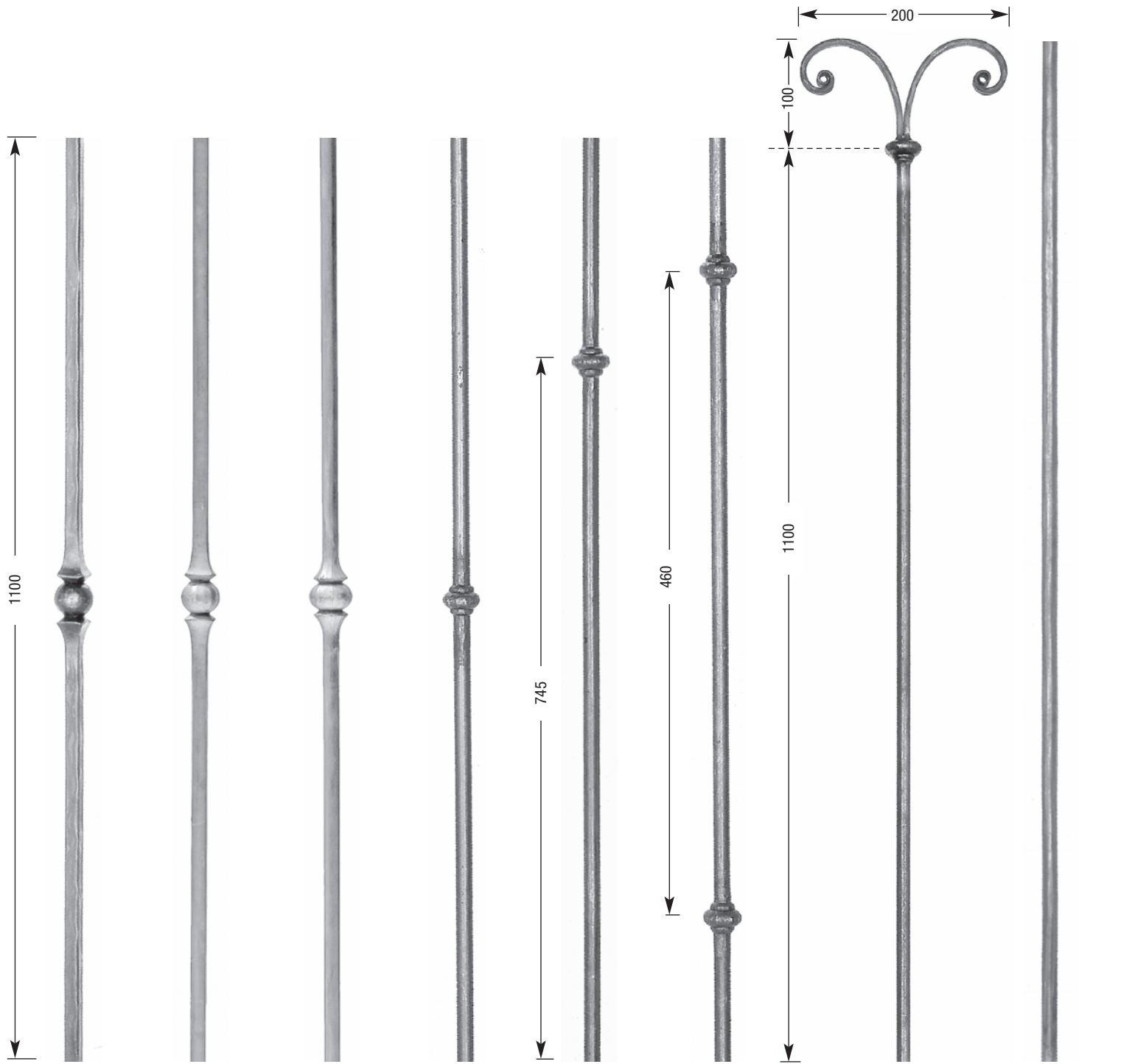

*	*	*	*	*	*	*	*
MARTELÉ	LISSE	LISSE	LISSE	LISSE	LISSE	LISSE	LISSE
ART. 21-14-1100 H. 1100-□14	ART. 21L-14-1100 H. 1100-□14	ART. 15L-14-1100 H. 1100-Ø14	ART. 20-14-1100 H. 1100-Ø14	ART. 20D-14-1100 H. 1100-Ø14	ART. 20D2-14-1100 H. 1100-Ø14	ART. 25ABIS-14-1200 H. 1200-Ø14	ART. RL14-1200 H. 1200-Ø14
							ART. RL14-1100 H. 1100-Ø14

TRAVERSES POINÇONNÉES POUR GARDE CORPS

Hauteur 2000 - Vide 100



ART. TR10-14 TROU Ø 14 - 16 TROUS
 □ 25 x 10

ÉLÉMENTS GARDE CORPS

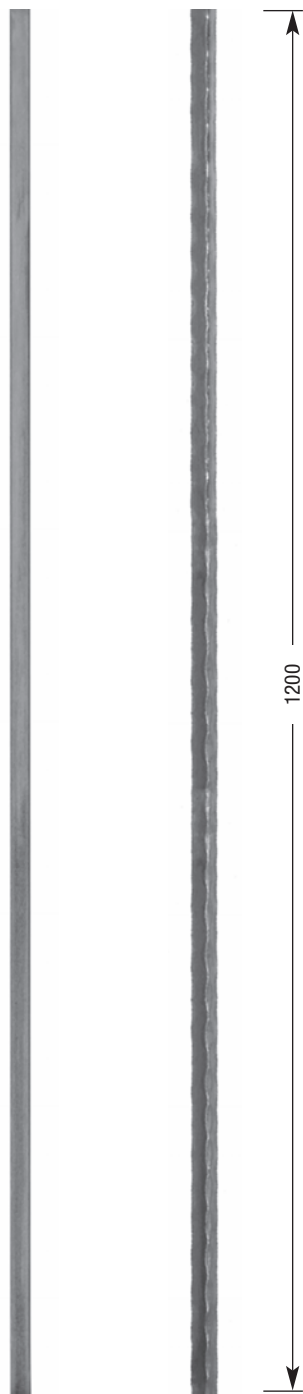

1200

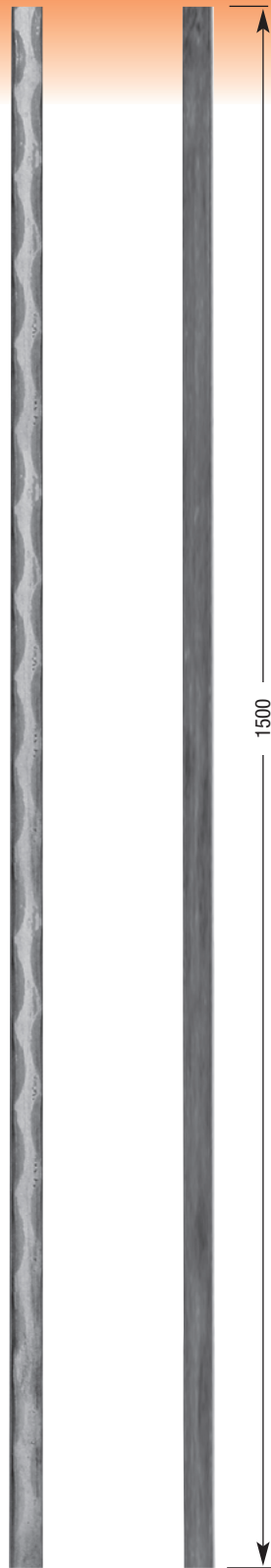

1500

**TUBE PRÉPERCÉ
POUR SERRURE
STREMLER**

Tube 40x40 - H. 1500

**TUBE GÂCHE
PRÉPERCÉ
POUR SERRURE
STREMLER**

Tube 40x40 - H. 1500

**ENTRÉE
DE
SERRURE**



ART. ES1
L 25 x H 50
ép. 6 mm

**SERRURE
STREMLER**
pour portillon
de piscine



ART. SERPISCINE

**PLAT-GACHE
PRÉPERCÉ**



Plat 40 x 10
H. 300

ART. PLATA

**PAUMELLE
TRUCLOSE
automatique**



ART. PAUM
(vendu par paire)

**Poignée
ART. POIGNÉE-A-7**

□ 7 mm

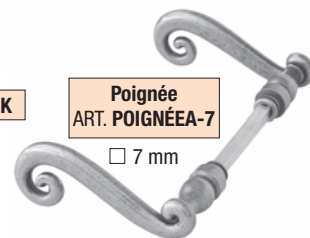

Cylindre
largeur 60 mm

ART. CYLINDREA-60

* LISSE	* MARTELÉ
ART. CL14-1200 H. 1200-□14	ART. CM14-1200 H. 1200-□14
ART. CL14-1100 H. 1100-□14	ART. CM14-1100 H. 1100-□14

MARTELÉ	LISSE
ART. CM25-1500 H. 1500-□25	ART. CL25-1500 H. 1500-□25

ART. TUBEA

ART. TUBEK



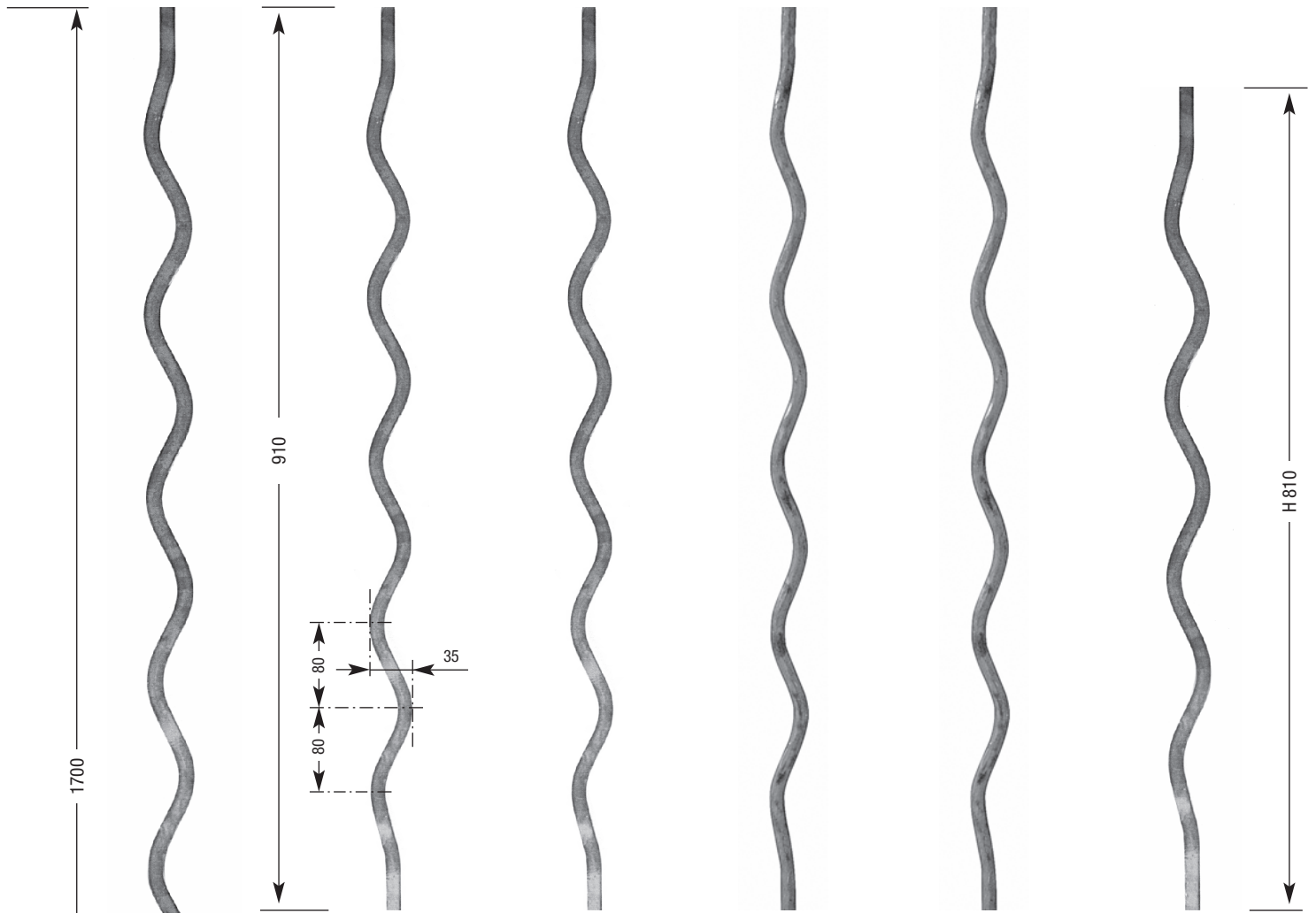

LISSE
ART. 7L-14-910 H. 910 - □14
ART. 7L-16-910 H. 910 - □16

MARTELÉ
ART. 7M-14-910 H. 910 - □14
ART. 7M-16-910 H. 910 - □16

LISSE
ART. 7LR-14-910 H. 910 - Ø14
ART. 7LR-16-910 H. 910 - Ø16

MARTELÉ
ART. 7MR-14-910 H. 910 - Ø14
ART. 7MR-16-910 H. 910 - Ø16

LISSE
ART. 7L-14-810 H. 810 - □14
ART. 7L-16-810 H. 810 - □16

LISSE
ART. 7L-14-1700 H. 1700 - □14
ART. 7L-14-6000 H. 6000 - □14



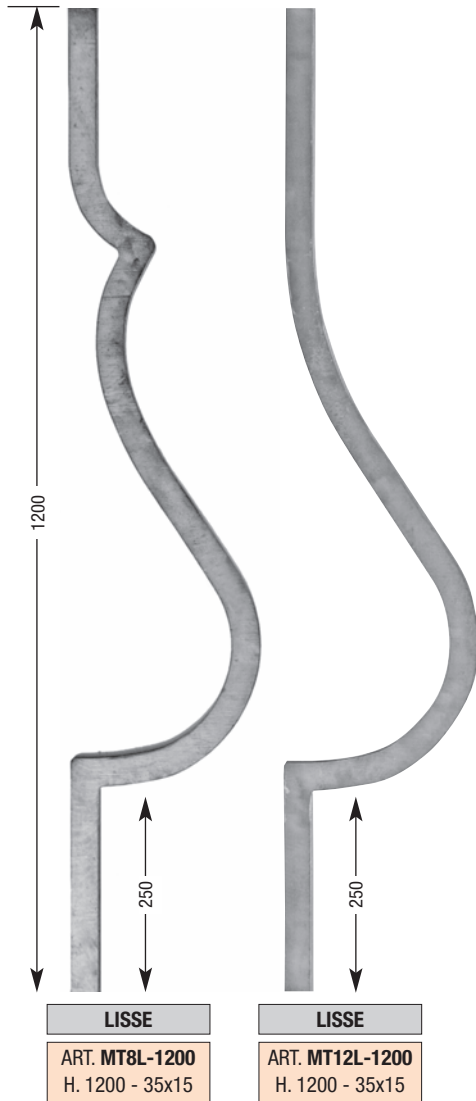

LISSE
 ART. MT8L-1200
 H. 1200 - 35x15

LISSE
 ART. MT12L-1200
 H. 1200 - 35x15

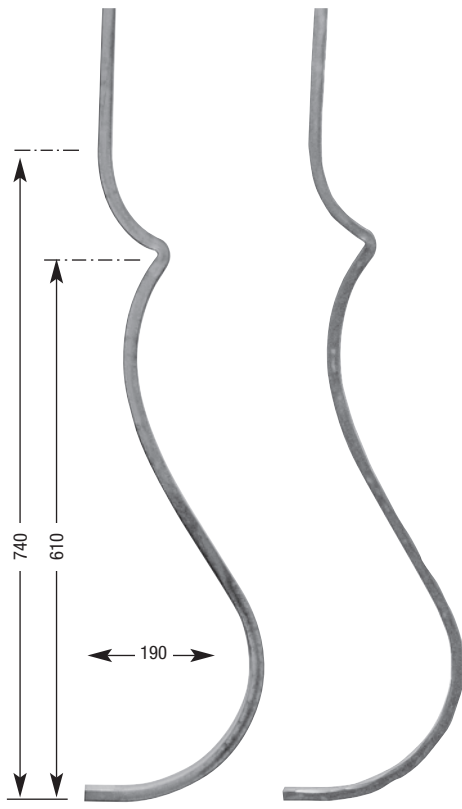

LISSE

- ART. 8L-14-910
H. 910 - □14
- ART. 8L-16-910
H. 910 - □16

MARTELÉ

- ART. 8M-14-910
H. 910 - □14
- ART. 8M-16-910
H. 910 - □16

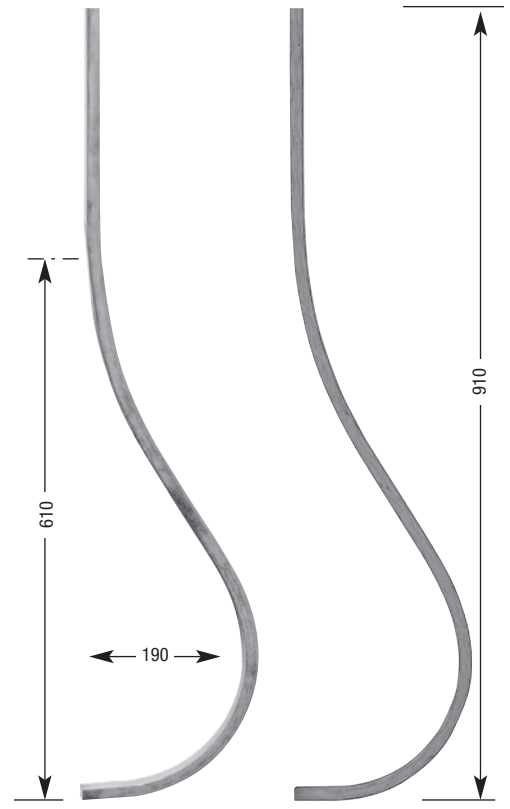

LISSE

- ART. 12L-14-910
H. 910 - □14
- ART. 12L-16-910
H. 910 - □16

MARTELÉ

- ART. 12M-14-910
H. 910 - □14
- ART. 12M-16-910
H. 910 - □16

- ART. 8L-14-1300
H. 1300 - □14
- ART. 8L-16-1300
H. 1300 - □16
- ART. 8L-14-1800
H. 1800 - □14
- ART. 8L-16-1800
H. 1800 - □16

- ART. 12L-14-1300
H. 1300 - □14
- ART. 12L-16-1300
H. 1300 - □16
- ART. 12L-14-1800
H. 1800 - □14
- ART. 12L-16-1800
H. 1800 - □16

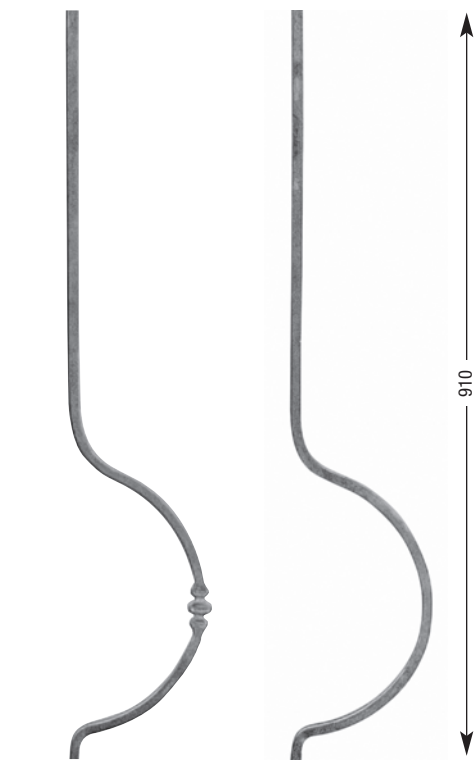

LISSE
 ART. 103GLS-14-910
 H. 910 - □14

LISSE
 ART. 1GLSB-14-910
 H. 910 - □14

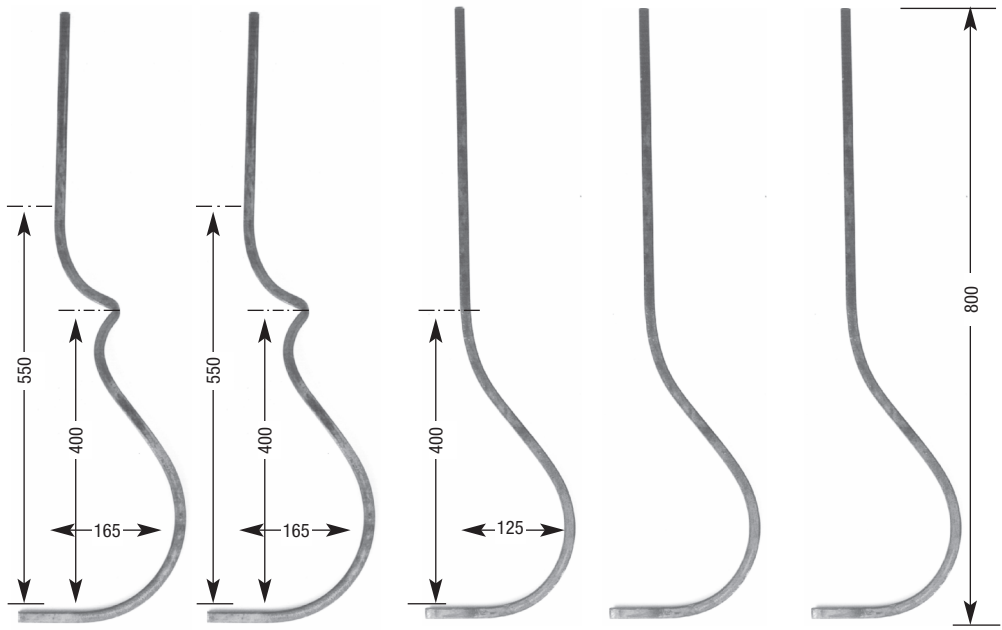

LISSE

- ART. 8CL-14-800
H. 800 - □14

MARTELÉ

- ART. 8CM-14-800
H. 800 - □14

LISSE

- ART. 12CL-14-800
H. 800 - □14

MARTELÉ

- ART. 12CM-14-800
H. 800 - □14

LISSE

- ART. 12CRL-14-800
H. 800 - Ø14

BARREAUX DE BALCON TORSADÉS

Hauteurs différentes sur commande

BARREAU EN TUBE RETREIN

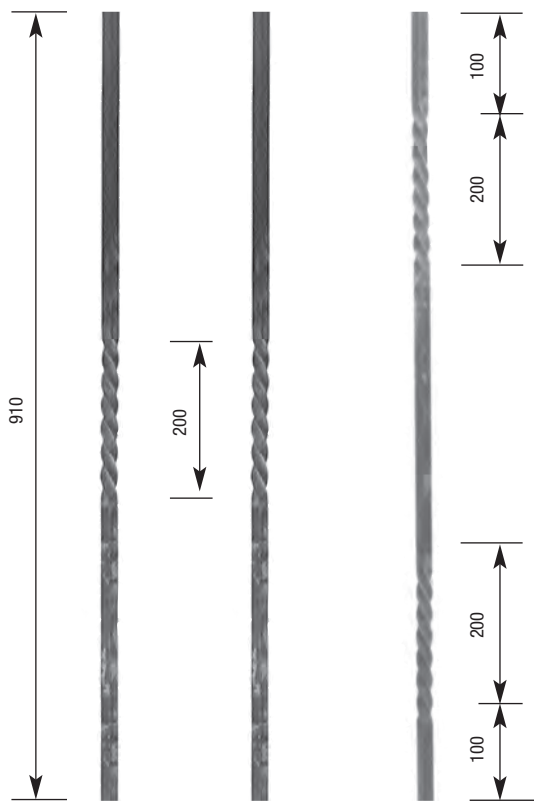
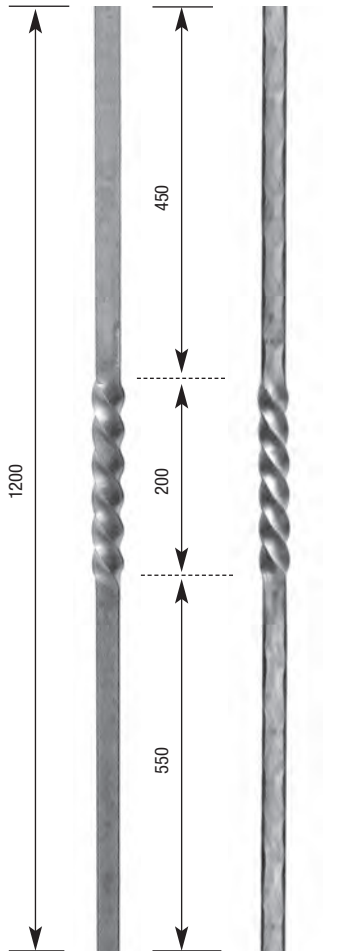

LISSE	MARTELÉ
ART. MTT1L-25-1200 H. 1200-□25	ART. MTT1M-25-1200 H. 1200-□25

LISSE	MARTELÉ	LISSE	MARTELÉ	LISSE
ART. T1L-14-910 H. 910-□14	ART. T1M-14-910 H. 910-□14	ART. T2L-14-910 H. 910-□14	ART. T2M-14-910 H. 910-□14	ART. TL-14-910 H. 910-□14
ART. T1L-16-910 H. 910-□16	ART. T1M-16-910 H. 910-□16	ART. T2L-16-910 H. 910-□16	ART. T2M-16-910 H. 910-□16	ART. TL-16-910 H. 910-□16
ART. T1L-18-910 H. 910-□18	ART. T1M-18-910 H. 910-□18	ART. T2L-18-910 H. 910-□18	ART. T2M-18-910 H. 910-□18	ART. TL-18-910 H. 910-□18
ART. T1L-20-910 H. 910-□20	ART. T1M-20-910 H. 910-□20	ART. T2L-20-910 H. 910-□20	ART. T2M-20-910 H. 910-□20	ART. TL-20-910 H. 910-□20

LISSE
ART. 81L-14X6-910 H. 910-□14x6

LISSE
ART. RET1-910 H. 910

GARNITURE DE BARREAU

Modèle déposé International

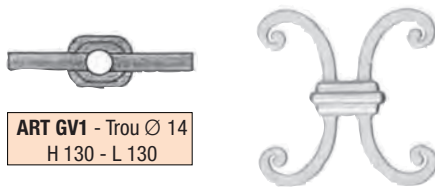

ART GV1 - Trou Ø 14
H 130 - L 130

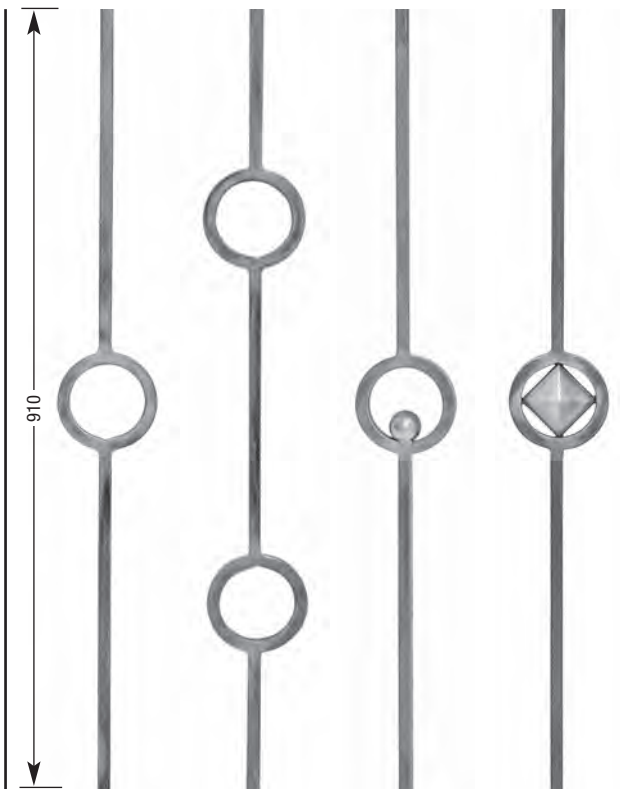
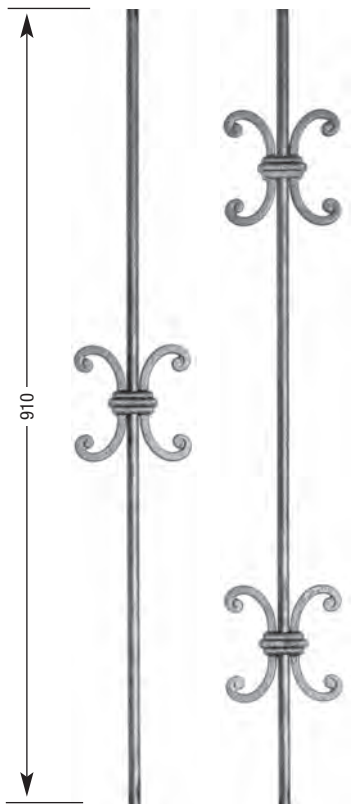
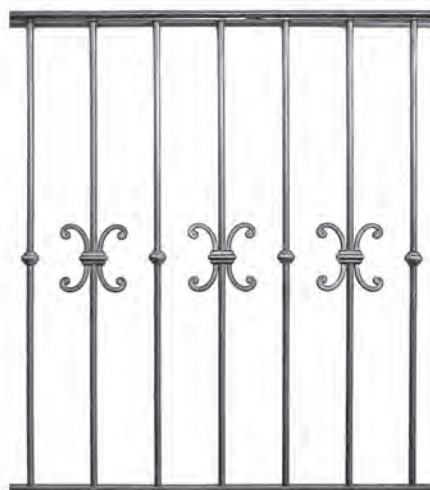

LISSE	LISSE
ART. 56-14-910 H. 910 - Ø14	ART. 57-14-910 H. 910 - Ø14

LISSE	LISSE	LISSE	LISSE
ART. 82L-14-910 H. 910-□14 anneau Ø 110	ART. 82LD-14-910 H. 910-□14 anneau Ø 110	ART. 83L-14-910 H. 910-□14 anneau Ø 110	ART. 84L-14-910 H. 910-□14 anneau Ø 110

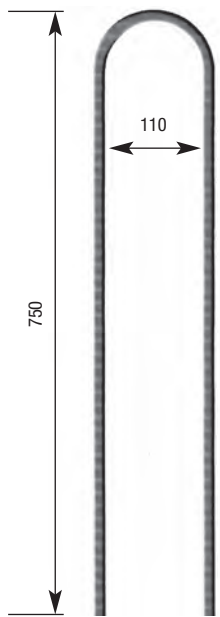

LISSE
ART. 54-14-750
H. 750 - □14



LISSE
ART. 59-14-750
H. 750 - Ø14



LISSE
ART. 64-14-910
H. 910 - □14
ART. 64-14-1200
H. 1200 - □14
ART. 64-14-1500
H. 1500 - □14



LISSE
ART. 63-14-910
H. 910 - Ø14
ART. 63-14-1200
H. 1200 - Ø14
ART. 63-14-1500
H. 1500 - Ø14



LISSE
ART. 65-14-1200
H. 1200 - □14
ART. 65-14-1500
H. 1500 - □14



LISSE
ART. 66-14-1200
H. 1200 - Ø14
ART. 66-14-1500
H. 1500 - Ø14

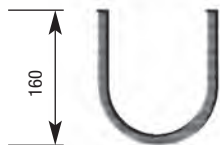

LISSE
ART. 55-14-160
H. 160 - □14



LISSE
ART. 60-14-160
H. 160 - Ø14



LISSE
ART. 62-14-910
H. 910 - □14



LISSE
ART. 61-14-910
H. 910 - Ø14

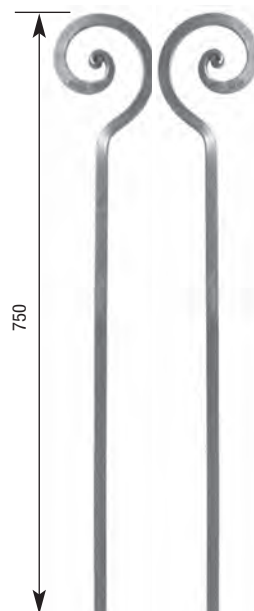
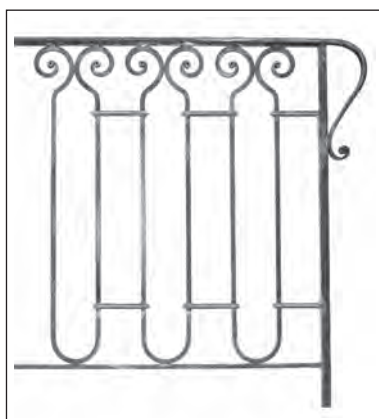
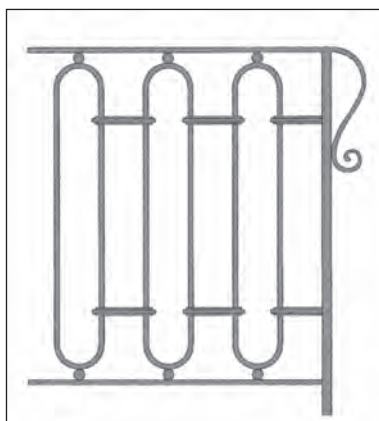

LISSE
ART. 58-14-750
H. 750 - □14



LISSE
ART. 55-14-160
H. 160 - □14

BARETTES MOULURÉES

*modèles déposés



ART. BA2 trous □14



ART. BA1 trous Ø14



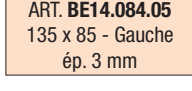
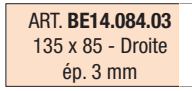
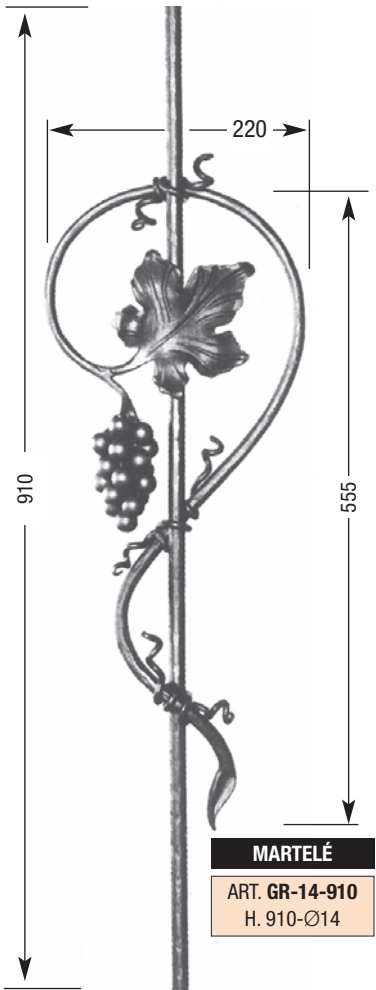

barreau 15MB-14-910 Ø 14
barreau GR-14-910 Ø 14
montant fort MT15C-25-1200 □ 25
boule B4
volute VOLS45G
crosse S45G

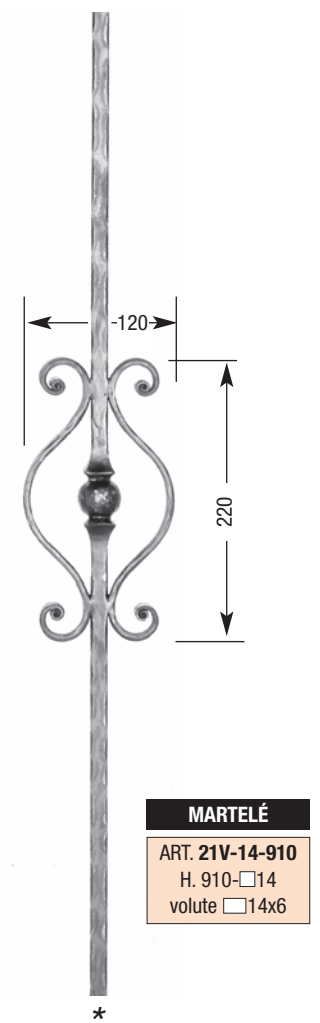
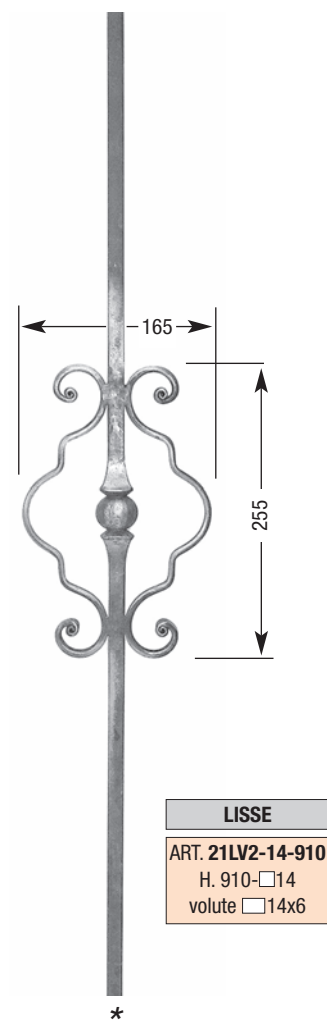
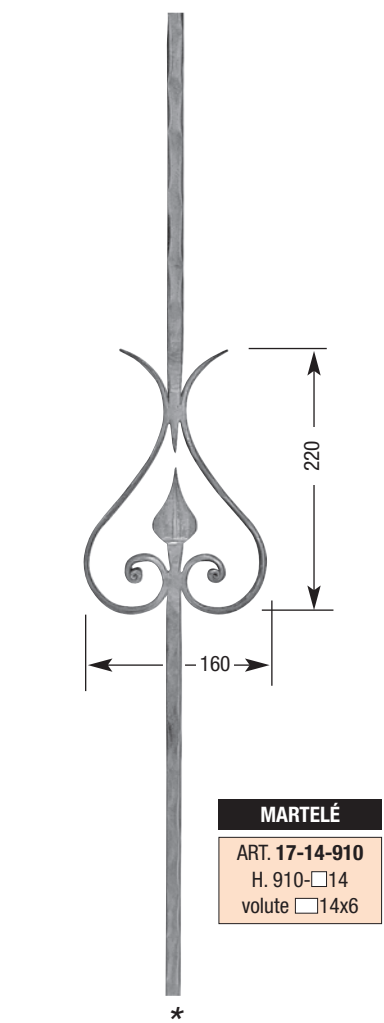
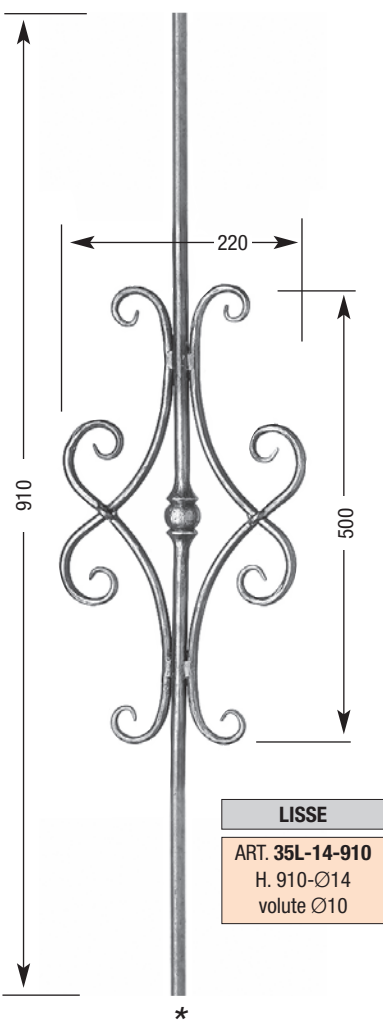

BARREAUX FORGÉS DÉCORATIFS

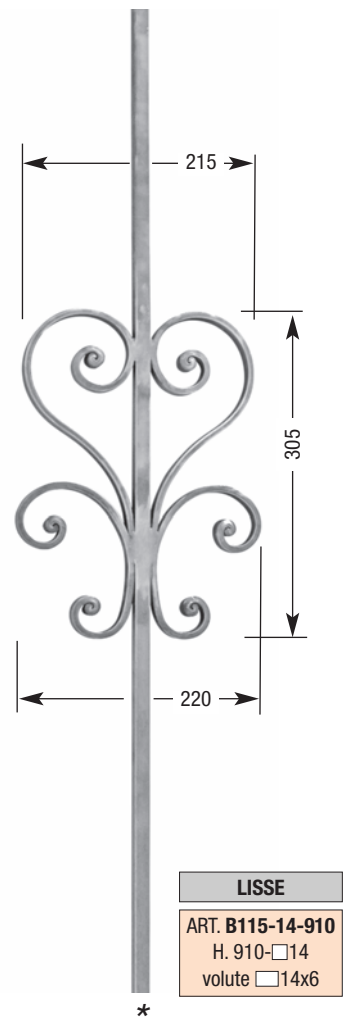
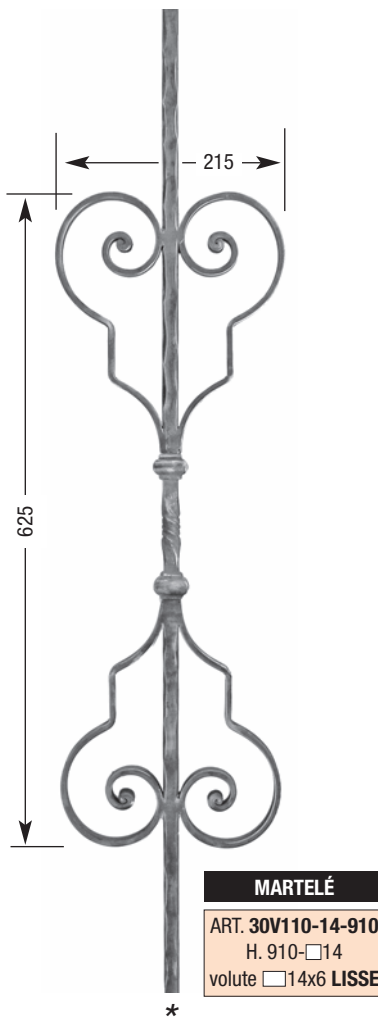
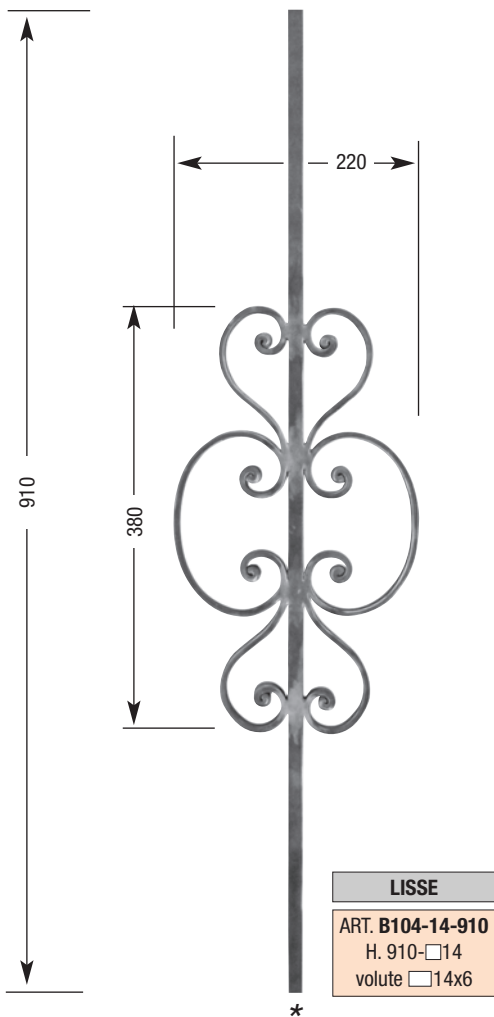
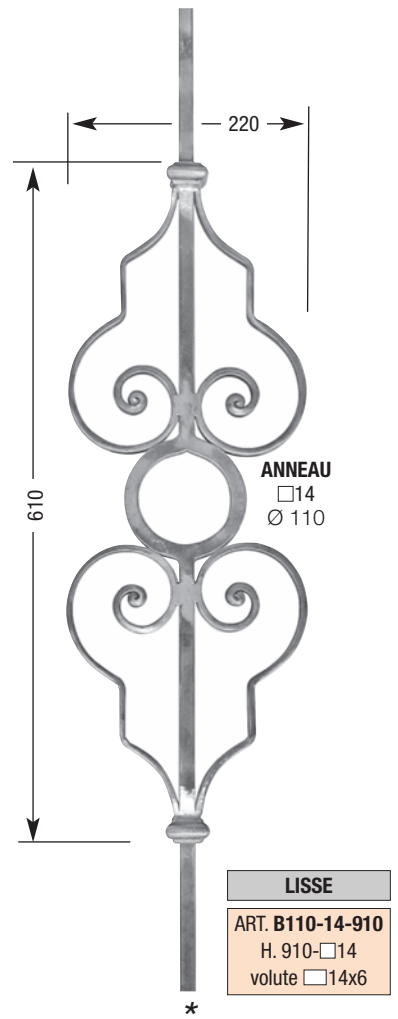
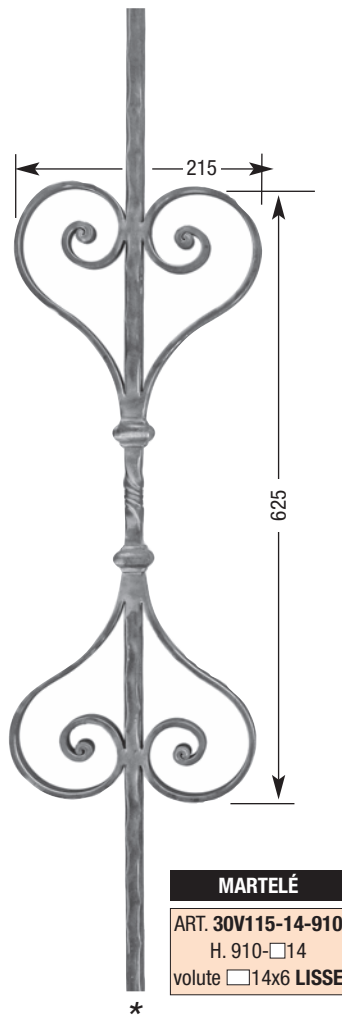
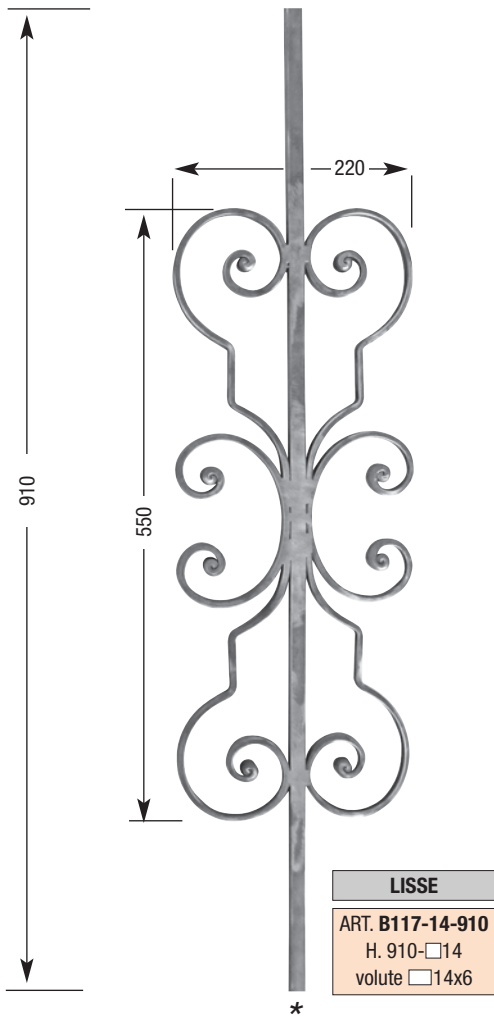

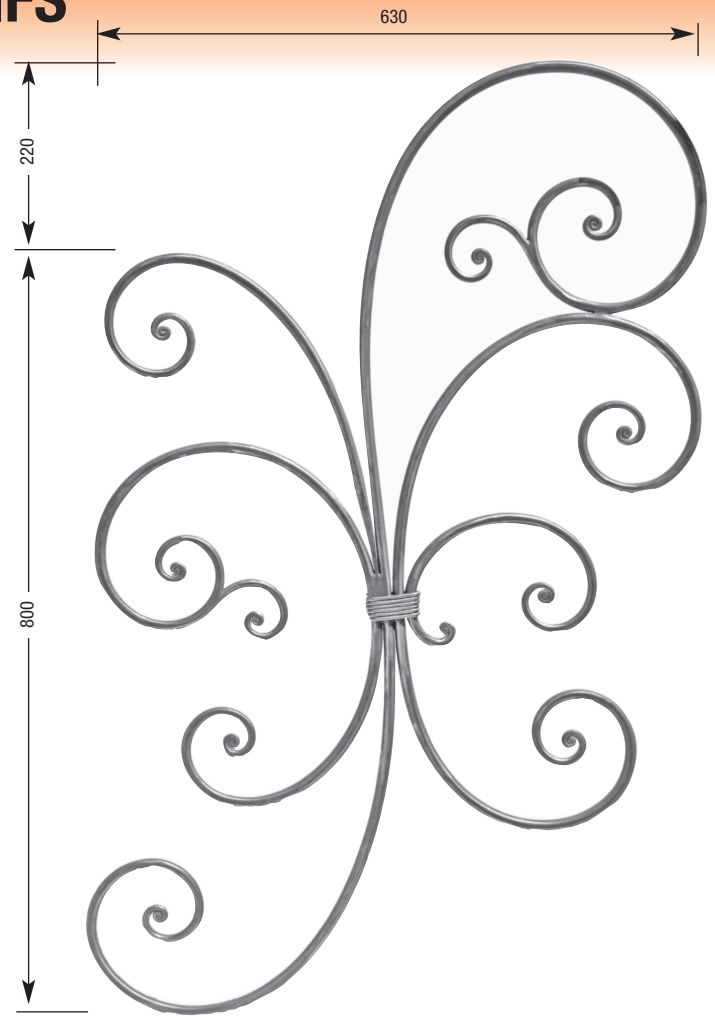

*

LISSE

ART. PANV4-12-800
 H. 800 - Ø12

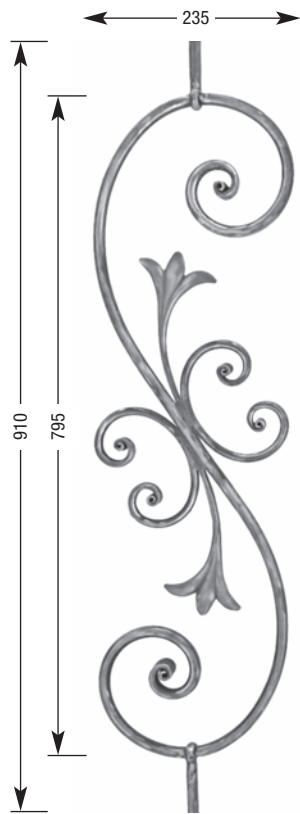

*

LISSE

ART. PAN35-14-910
 H. 910 - Ø14

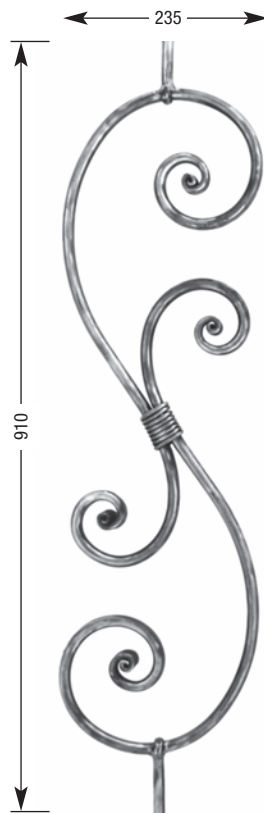

*

LISSE

ART. PANV-14-910
 H. 910 - Ø14

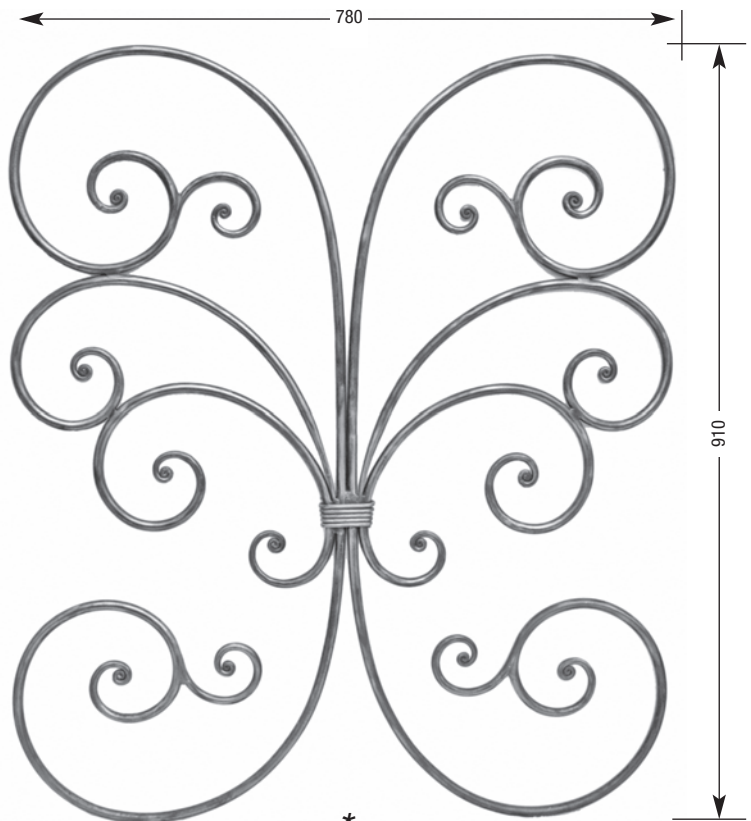

*

LISSE

ART. PANV5-12-910
 H. 910 - Ø12

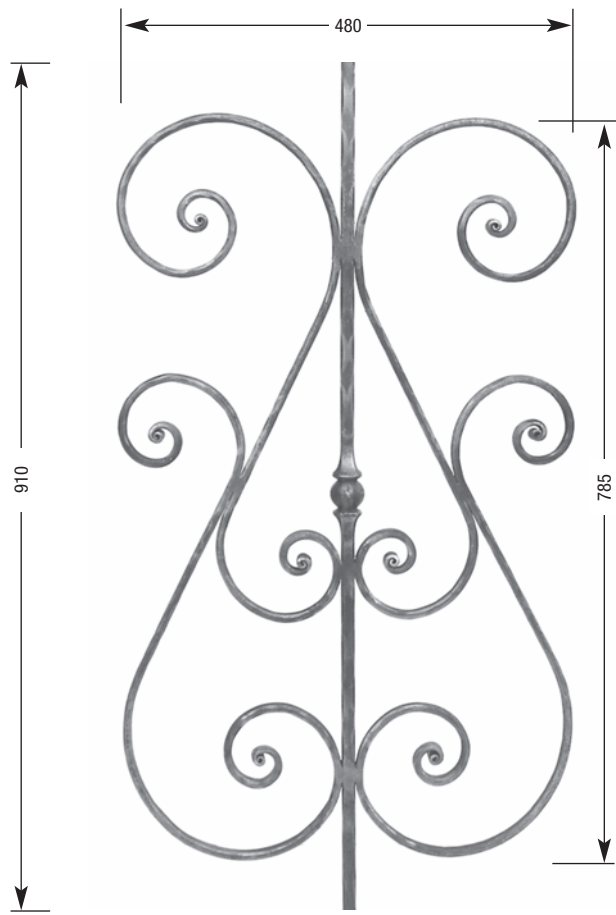

MARTELÉ
 ART. PAN21-14-910
 H. 910 - □14 - Vol. □14x8

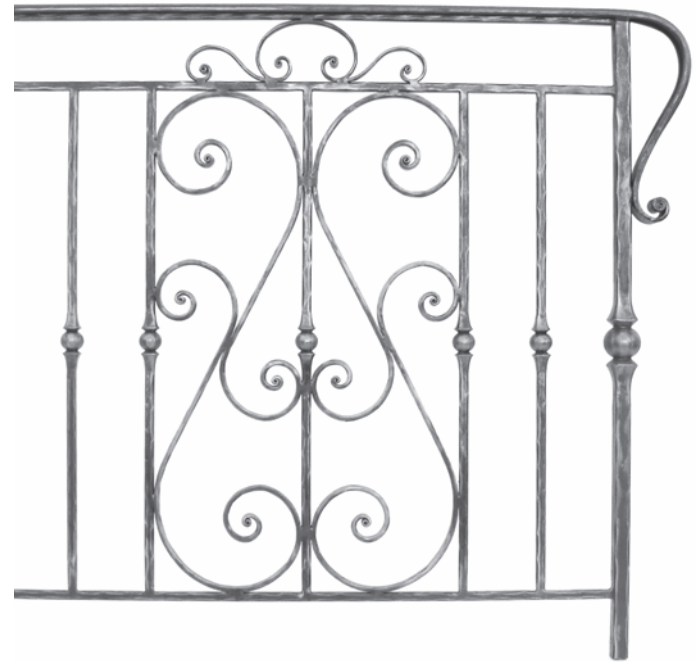

- | | | |
|----------------|--------------|--------|
| PANNEAU VOLUTE | PAN21-14-910 | □ 14 |
| barreau | 21-14-910 | □ 14 |
| montant fort | MT21-25-1200 | □ 25 |
| volute | V204M | □14x6 |
| crose | S45 | |
| carré martelé | CM14-2000 | H 2000 |

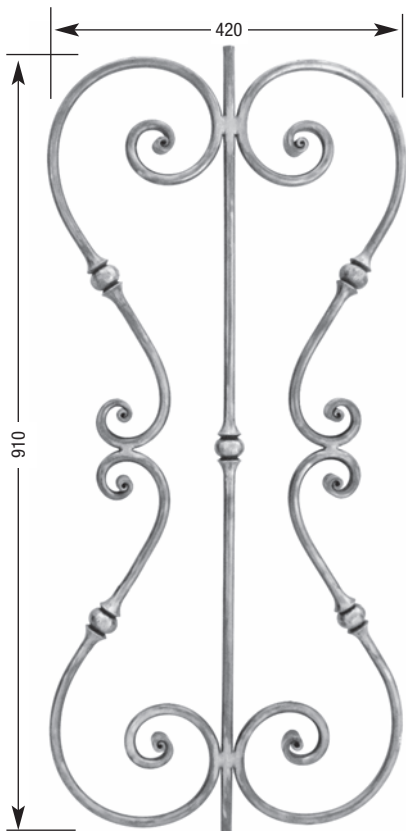

LISSE
 ART. PAN15L-14-910
 H. 910 - Ø14

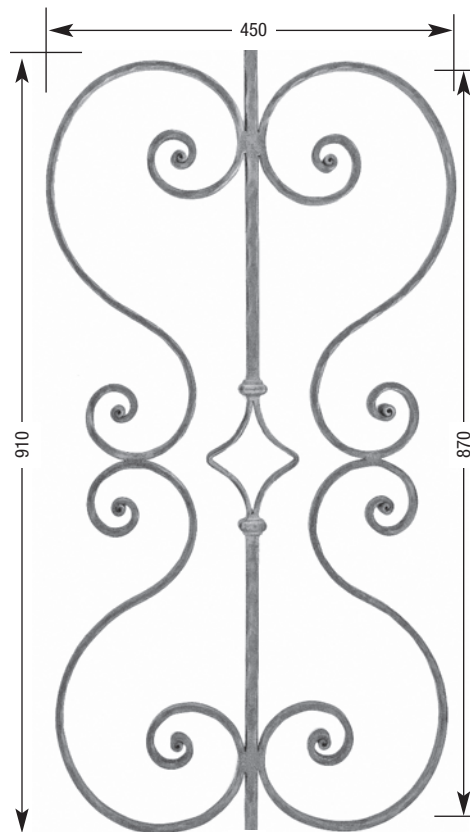

MARTELÉ
 ART. PAN29-14-910
 H. 910 - □14 - Vol. □14x8

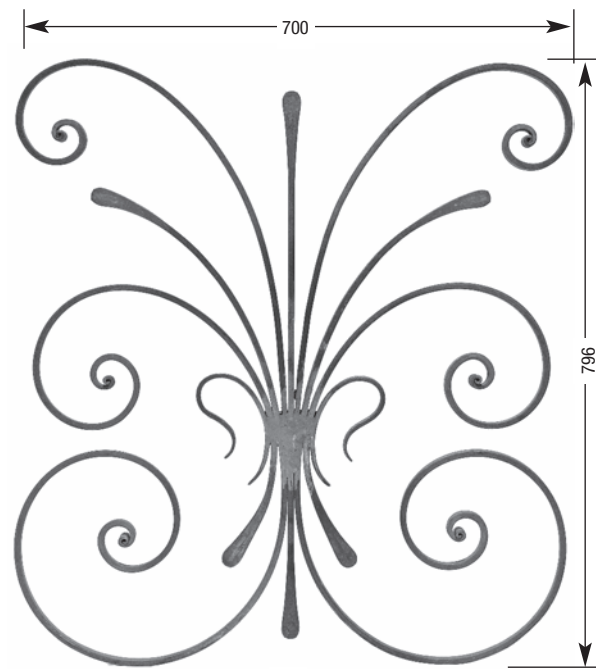

LISSE
 ART. PANV6
 H. 796 - □14 X 8



LISSE

ART. 071-88-119
 H. 940 x L. 500
 section Ø12
 Double face



LISSE

ART. 070-88-119
 H. 940 x L. 500
 section Ø12
 Double face



LISSE

ART. 072-88-119
 H. 980 x L. 600
 section Ø12
 Double face



LISSE

ART. 073-88-119
 H. 980 x L. 600
 section Ø12
 Double face



LISSE

ART. BRF6-210
 H. 900 x L. 500
 section □ 16 x 8

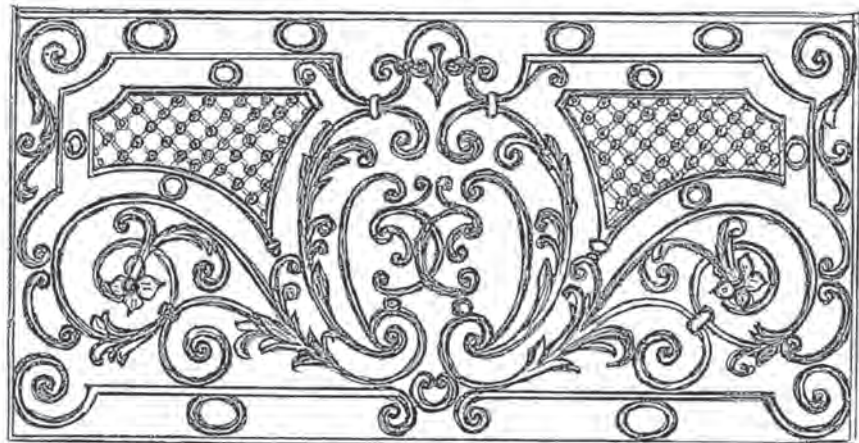

LISSE

ART. BRF6-204
 H. 900 x L. 1800
 section □ 16 x 8

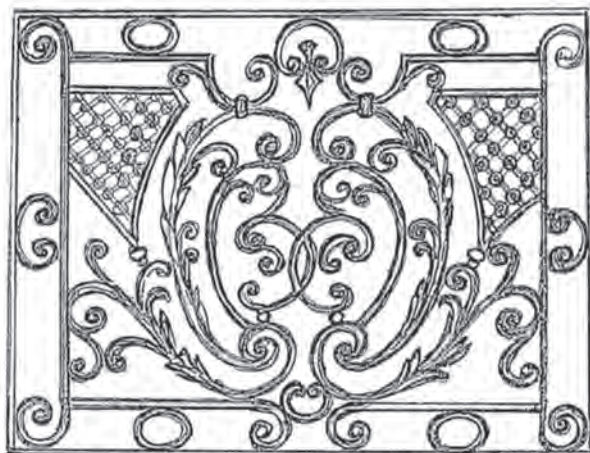

LISSE

ART. BRF6-206
 H. 900 x L. 1200
 section □ 16 x 8



LISSE

ART. BRF6-208
 H. 900 x L. 800
 section □ 16 x 8



MARTELÉ
 ART. BRF7-106-S
 H. 800 x L. 750
 section Ø 12 - 14



MARTELÉ
 ART. BRF7-106-D
 H. 800 x L. 750
 section Ø 12 - 14



MARTELÉ
 ART. BRF7-107-S
 H. 880 x L. 750
 section Ø 12 - 14



MARTELÉ
 ART. BRF7-107-D
 H. 880 x L. 750
 section Ø 12 - 14



MARTELÉ
 ART. BRF14-25
 H. 730 x L. 1000
 section Ø 8 - 10 - 14



MARTELÉ
 ART. BRF14-15
 H. 830 x L. 1000
 section Ø 8 - 10 - 14



MARTELÉ
 ART. BRF14-4
 H. 930 x L. 750
 section □ 16 - Ø 14



MARTELÉ
 ART. BRF14-34
 H. 750 x L. 660
 section Ø 12



LISSE
 ART. BRF14-45
 H. 780 x L. 800
 section Ø 14



LISSE
 ART. BRF14-47
 H. 750 x L. 900
 section Ø 14



LISSE

ART. BRF6-175
 H. 760 x L. 835
 section □ 16 x 10



LISSE

ART. BRF6-176
 H. 770 x L. 840
 section □ 16 x 10



LISSE

ART. BRF6-177
 H. 910 x L. 1250
 section □ 16 x 10



LISSE

ART. BRF6-191
 H. 850 x L. 1250
 section □ 16 x 10



LISSE

ART. BRF6-192
 H. 850 x L. 600
 section □ 16 x 10



LISSE

ART. BRF6-194
 H. 850 x L. 150
 section □ 16 x 10



LISSE

ART. BRF6-195
 H. 825 x L. 1475
 section □ 16 x 10



LISSE

ART. BRF6-226
 H. 950 x L. 620
 section □ 16 x 10



LISSE

ART. BRF6-232
 H. 830 x L. 270
 section □ 12



LISSE

ART. BRF14-37
H. 750 x L. 620
section Ø 12



LISSE

ART. BRF14-40
H. 750 x L. 750
section Ø 12



*

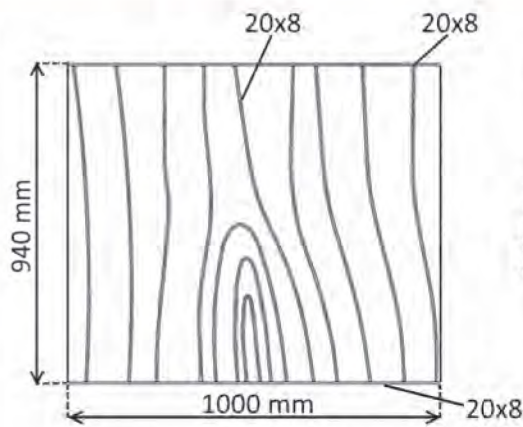
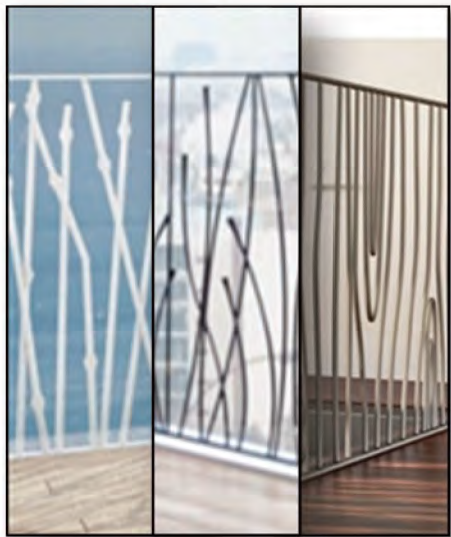

LISSE

ART. BT6042W010
L. 1000 - H. 940
section ■ 20 x 8

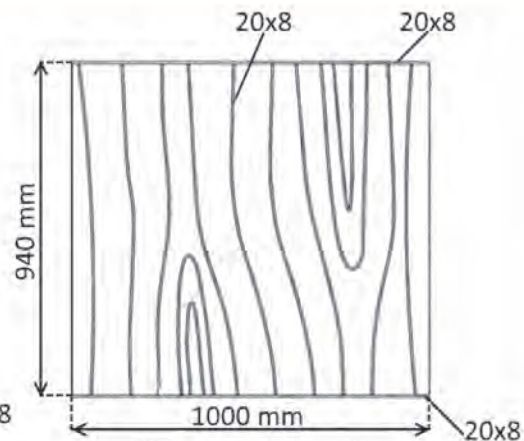

LISSE

ART. BT6041W010
L. 1000 - H. 940
section ■ 20 x 8

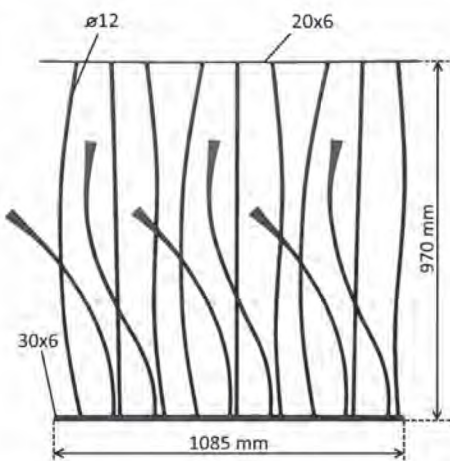

LISSE

ART. BT60301020
L. 1085 - H. 970
● 12 - ■ 20x6 - ■ 30x6

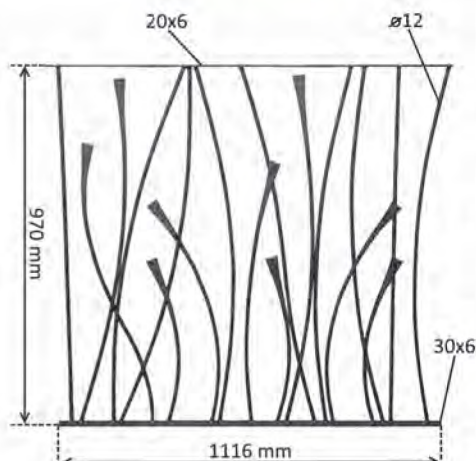

LISSE

ART. BT60301010
L. 1116 - H. 970
● 12 - ■ 20x6 - ■ 30x6

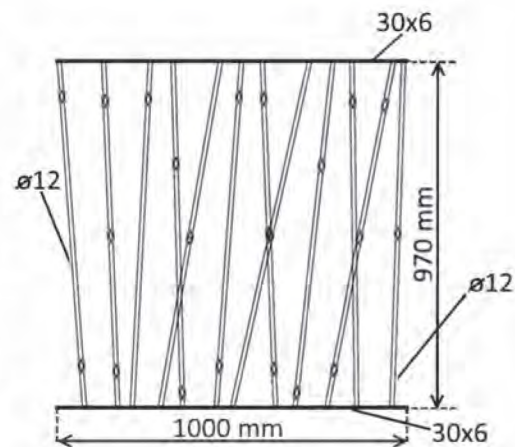

LISSE

ART. GCD-74-12
L. 1000 - H. 970
● 12 - ■ 30x6

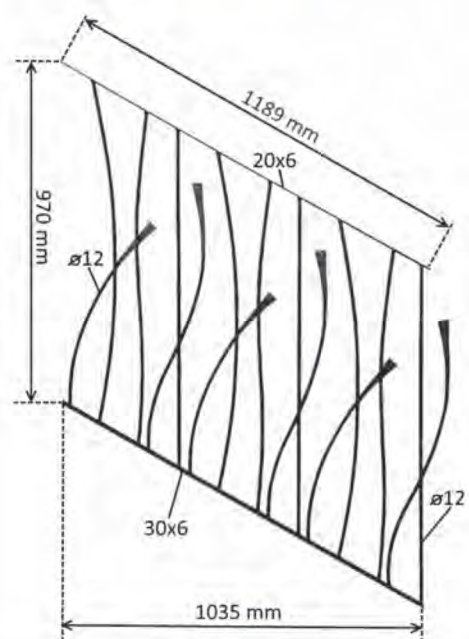

LISSE

ART. BT60302020
L. 1189 - H. 970
● 12 - ■ 20x6 - ■ 30x6

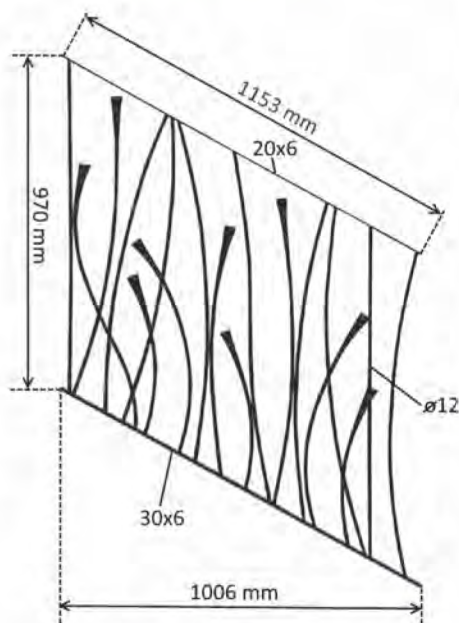

LISSE

ART. BT60302010
L. 1153 - H. 970
● 12 - ■ 20x6 - ■ 30x6

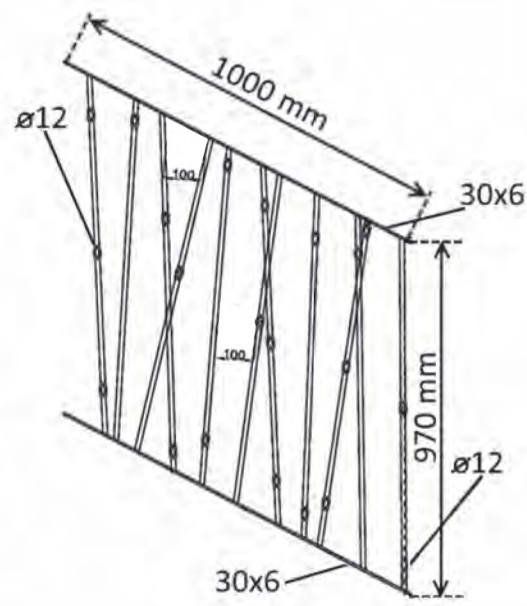

LISSE

ART. GCD-74-12P
L. 1000 - H. 970
● 12 - ■ 30x6

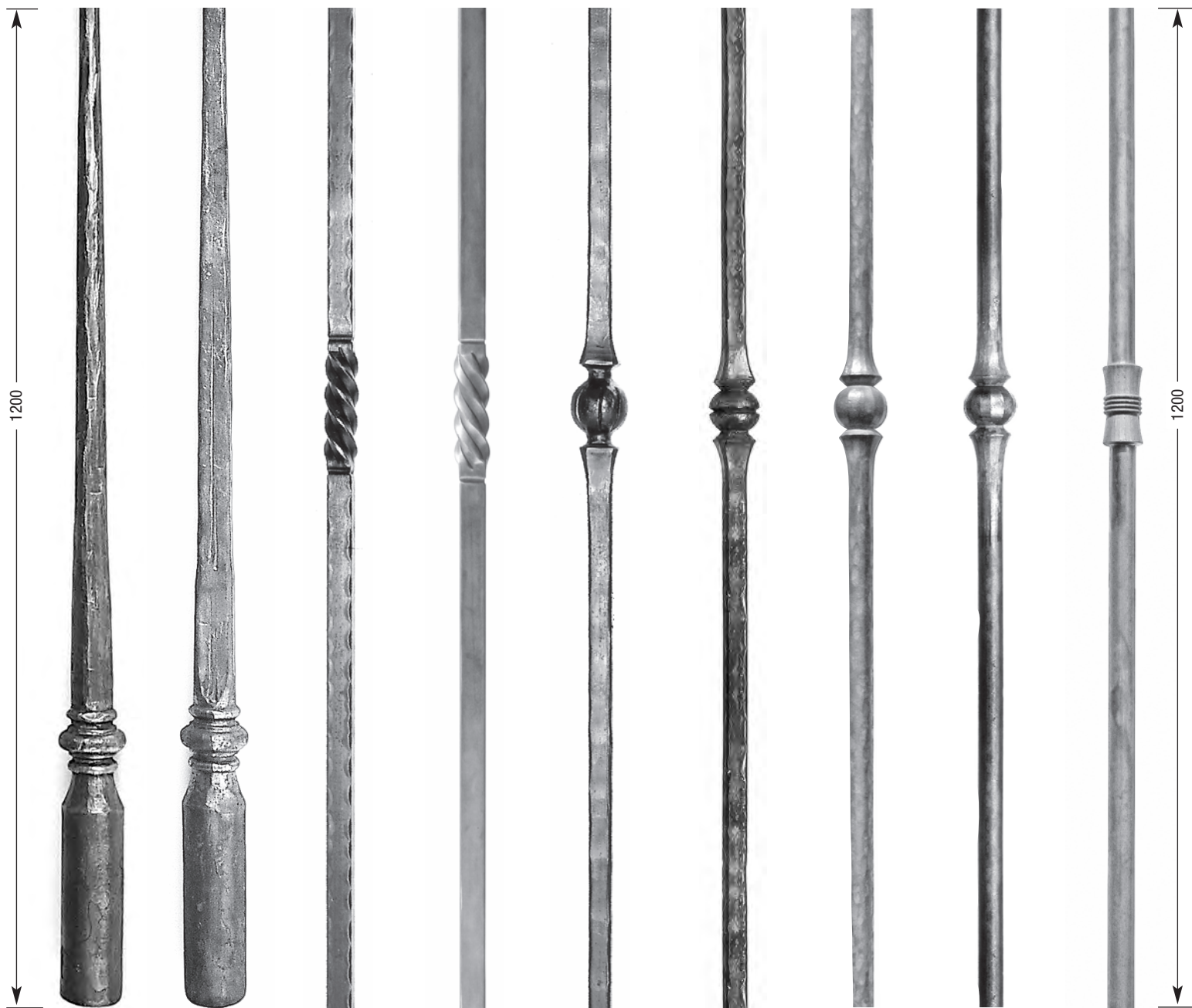

MARTELÉ	MARTELÉ	MARTELÉ	LISSE	MARTELÉ	MARTELÉ	MARTELÉ	LISSE	LISSE
ART. MT41-1200 H. 1200-Ø22 Base Ø65	ART. MT40-1200 H. 1200-□22 Base Ø65	ART. MT25-25-1200 H. 1200 - □ 25	ART. MT25L-25-1200 H. 1200 - □ 25	ART. MT15-25-1200 H. 1200 - □ 25	ART. MT15C-25-1200 H. 1200 - □ 25	ART. MT15M-30-1200 H. 1200 - Ø30	ART. MT15L-30-1200 H. 1200 - Ø 30	ART. MT80L-30-1200 H. 1200-Ø 30
				ART. MT15-30-1200 H. 1200 - □ 30	ART. MT15C-30-1200 H. 1200 - □ 30		ART. MT15L-35-1200 H. 1200 - Ø 35	

PLATINES CACHE SCCELLEMENT

forgées

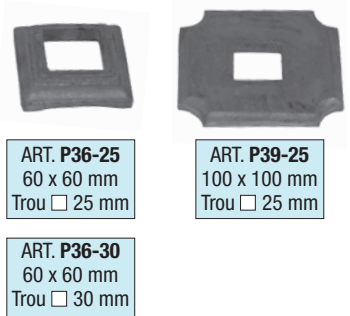

ART. P36-25 60 x 60 mm Trou □ 25 mm	ART. P39-25 100 x 100 mm Trou □ 25 mm
ART. P36-30 60 x 60 mm Trou □ 30 mm	

estampées

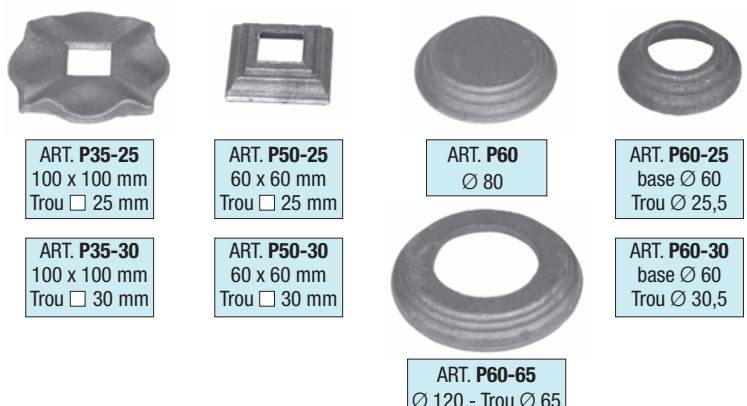

ART. P35-25 100 x 100 mm Trou □ 25 mm	ART. P50-25 60 x 60 mm Trou □ 25 mm	ART. P60 Ø 80	ART. P60-25 base Ø 60 Trou Ø 25,5
ART. P35-30 100 x 100 mm Trou □ 30 mm	ART. P50-30 60 x 60 mm Trou □ 30 mm	ART. P60-30 base Ø 60 Trou Ø 30,5	
		ART. P60-65 Ø 120 - Trou Ø 65	

PLATINES DE DEPART

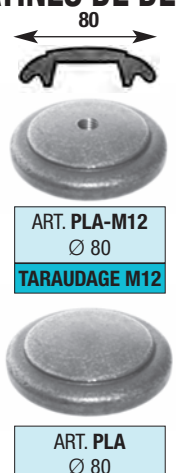

ART. PLA-M12 Ø 80 TARAUDAGE M12
ART. PLA Ø 80

Les côtes sont approximatives et données à titre indicatif. Les barreaux sont bruts à recouper et à redresser. *Modèle déposé



*	*	*	*	*	*	*	*	*	*
MARTELÉ	MARTELÉ	LISSE	MARTELÉ	MARTELÉ	MARTELÉ	LISSE	LISSE	LISSE	MARTELÉ
ART. MT30-25-1200 H. 1200 - □ 25	ART. MT21-25-1200 H. 1200 - □ 25	ART. MT21L-25-1200 H. 1200 - □ 25	ART. MT23-25-1200 H. 1200 - □ 25	ART. MT5-25-1200 H. 1200 - □ 25	ART. MT51-25-1200 H. 1200 - □ 25	ART. MT50-30-1200 H. 1200 - Ø 30	ART. MT38L-30-1200 H. 1200 - Ø 30	ART. MT39-25-1200 H. 1200 - □ 25	ART. MT39-25-1200 H. 1200 - □ 25
	ART. MT21-30-1200 H. 1200 - □ 30	ART. MT21L-30-1200 H. 1200 - □ 30	ART. MT23-30-1200 H. 1200 - □ 30		ART. MT51-30-1200 H. 1200 - □ 30				

BOULES DE DEPART DE RAMPE EN VERRE

MONTAGE FACILE

ART. BVA boule Ø 100 base Ø 45	ART. BVO boule Ø 100 base Ø 45	ART. BVV boule Ø 100 base Ø 45	ART. BVP boule Ø 100 base Ø 45	ART. BVZ boule Ø 100 base Ø 45	ART. BVM boule Ø 100 base Ø 45	ART. BVORR boule Ø 100 base Ø 45	ART. BVORW boule Ø 100 base Ø 45
--------------------------------------	--------------------------------------	--------------------------------------	--------------------------------------	--------------------------------------	--------------------------------------	--	--



MARTELÉ	LISSE	MARTELÉ	LISSE	MARTELÉ	LISSE	LISSE
ART. MT32M-25-1200 H. 1200-□ 25	ART. MT32L-25-1200 H. 1200 □ 25	ART. MT33-25-1200 H. 1200 □ 25	ART. MT31-30-1200 H. 1200-Ø 30	ART. MT22-25-1200 H. 1200-□ 25	ART. MT22L-25-1200 H. 1200-□ 25	ART. MT20-30-1200 H. 1200-Ø 30

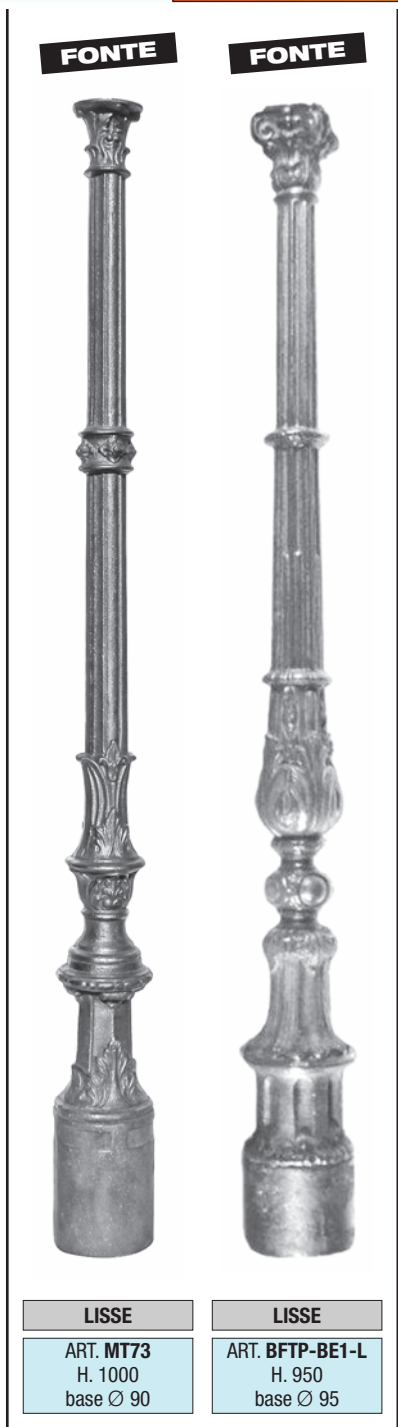

LISSE	LISSE
ART. MT73 H. 1000 base Ø 90	ART. BFTP-BE1-L H. 950 base Ø 95

BOULES DE DÉPART DE RAMPE EN ACIER



ART. B15
Ø 80
base □ 25
environ



ART. B16
Ø 85
base □ 25
environ



ART. B17
Ø 80
base □ 25
environ



ART. BD30
H 170 x 100
base Ø 40
environ



ART. BD40
H 100
base Ø 25
environ



ART. BD41
H 100
base □ 25
environ

FORTE

Percé Taraudé M12



Percé Taraudé M16

LISSE

ART. BFTP-BE2-L
 H. 1000 base Ø 95



LISSE

ART. 301
 H. 1070 - Ø 22



LISSE

ART. MT301
 H. 1200 - Ø 45



LISSE

ART. 302
 H. 1070 - Ø 16



LISSE

ART. MT302
 H. 1200 - Ø 32



LISSE

ART. 303
 H. 1070 - □ 22



LISSE

ART. MT303
 H. 1200 - □ 30



RALLONGE MONTANT

ART. BFTP-BE-RALLONGE
 H. 200 - Ø 50

*



TIGE FILETÉE

ART. TIGEM16-150
 H. 150 - M16

*



LISSE
 ART. MT304
 H. 1150 - Ø 40



LISSE
 ART. MT305
 H. 1150 - Ø 32

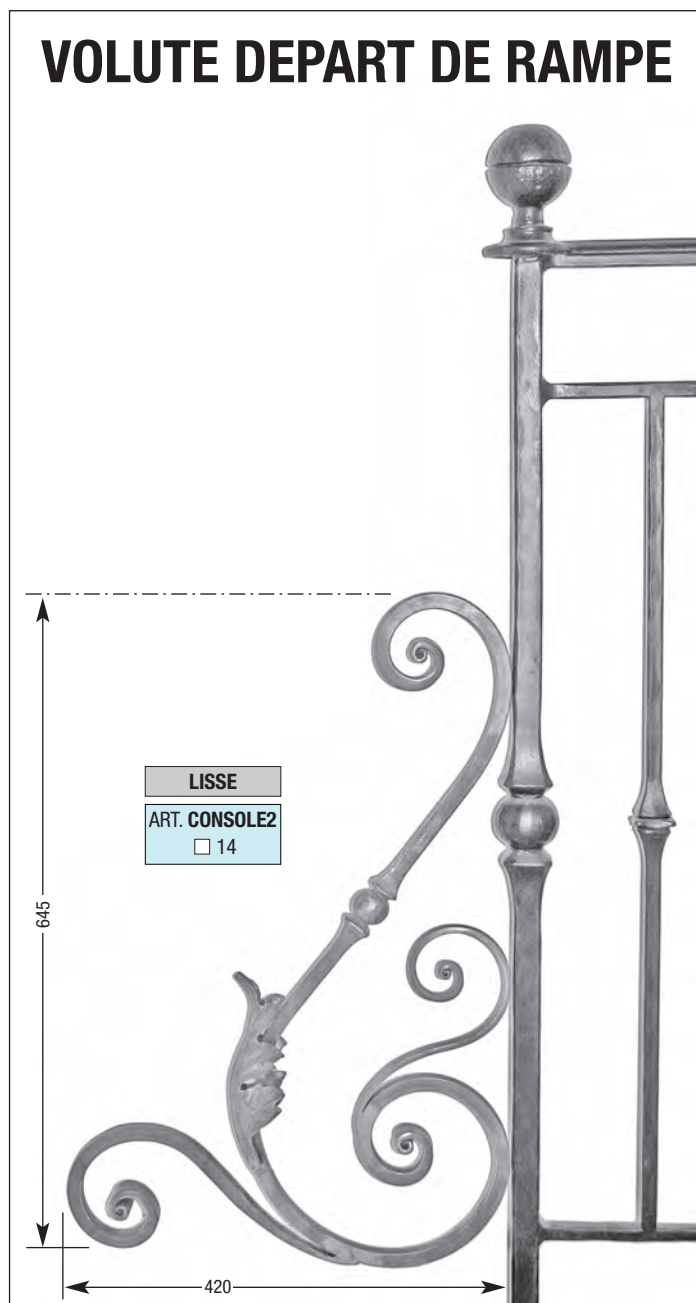

MONTANTS A TROUS RENFLÉS A CHAUD

TROUS RONDS

TROUS OVALES

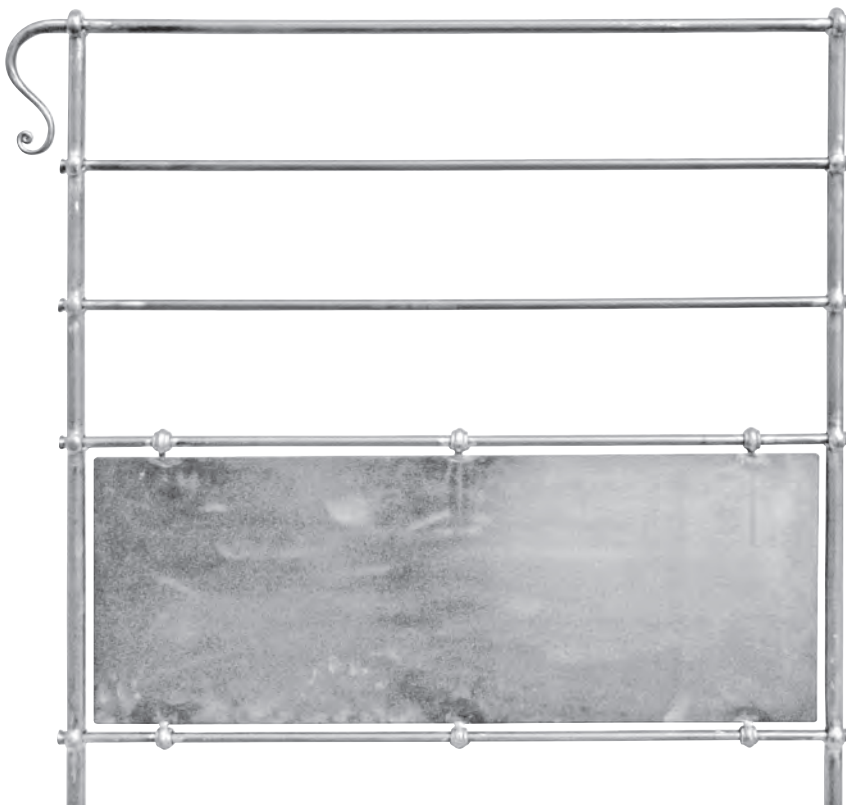
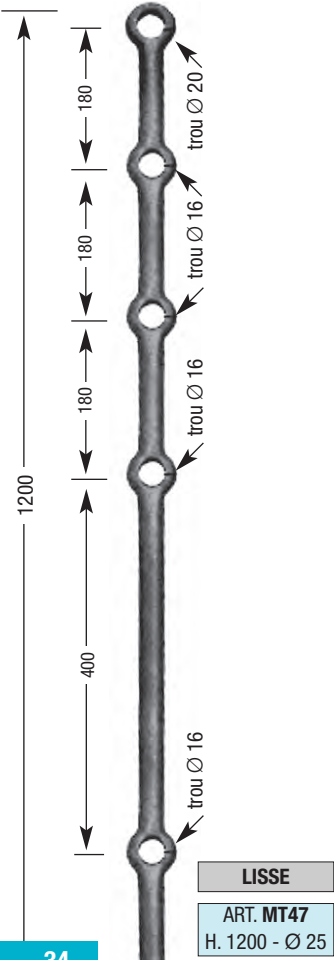
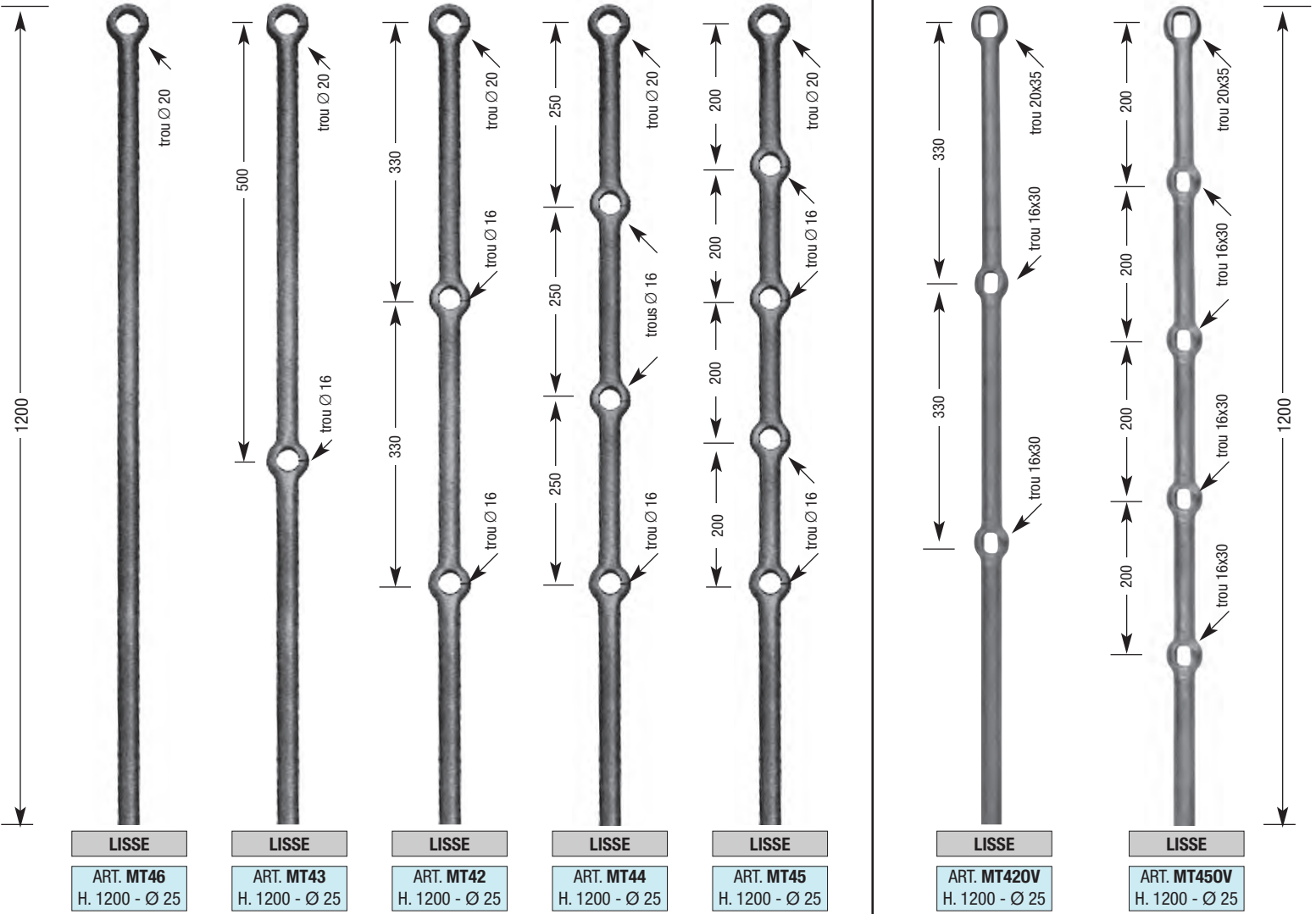

**Possibilité
 de découpe
 de tôle à la
 demande**

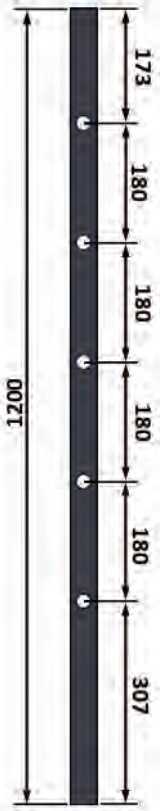

LISSE

ART. M5R14
5 trous - Ø14
H. 1200 - 40x12

ART. M5R16
5 trous - Ø16
H. 1200 - 40x12

ART. M5R20
5 trous - Ø20
H. 1200 - 40x12



LISSE

ART. M4R14
4 trous - Ø14
H. 1200 - 40x12

ART. M4R16
4 trous - Ø16
H. 1200 - 40x12

ART. M4R20
4 trous - Ø20
H. 1200 - 40x12



LISSE

ART. M3R14
3 trous - Ø14
H. 1200 - 40x12

ART. M3R16
3 trous - Ø16
H. 1200 - 40x12

ART. M3R20
3 trous - Ø20
H. 1200 - 40x12



LISSE

ART. M2R14
2 trous - Ø14
H. 1200 - 40x12

ART. M2R16
2 trous - Ø16
H. 1200 - 40x12

ART. M2R20
2 trous - Ø20
H. 1200 - 40x12

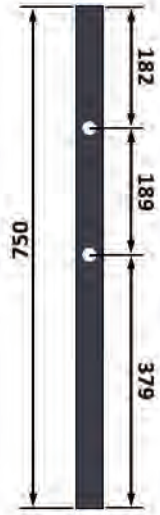

LISSE

ART. M2R14H750
2 trous - Ø14
H. 750 - 40x12

ART. M2R16H750
2 trous - Ø16
H. 750 - 40x12

ART. M2R20H750
2 trous - Ø20
H. 750 - 40x12



LISSE

ART. M9R14
9 trous - Ø14
H. 1200 - 40x12



LISSE

ART. M12R8
12 trous - Ø8
H. 1200 - 40x12

COUDE D'ANGLE

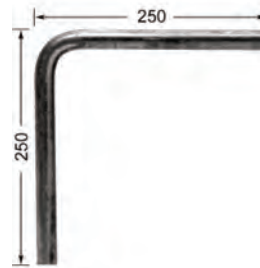

LISSE

ART. COUDEC14
H. 250 - L 250 - □14

LISSE

ART. COUDE14L
H. 250 - L 250 - Ø14

LISSE

ART. COUDE16L
H. 250 - L 250 - Ø16

LISSE

ART. COUDE20L
H. 250 - L 250 - Ø20

MAIN COURANTE



LISSE

ART. PL40x12-3000
H. 3000 - 40x12



LISSE

ART. MCM45x12
H. 3000 - 45x12

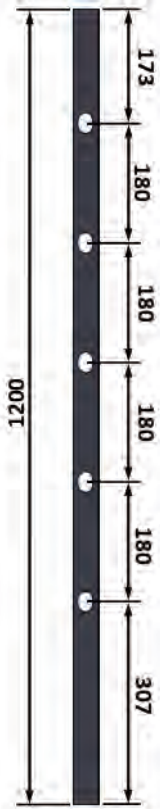

LISSE

ART. M5R14P
5 trous - Ø14
H. 1200 - 40x12

ART. M5R16P
5 trous - Ø16
H. 1200 - 40x12

ART. M5R20P
5 trous - Ø20
H. 1200 - 40x12



LISSE

ART. M4R14P
4 trous - Ø14
H. 1200 - 40x12

ART. M4R16P
4 trous - Ø16
H. 1200 - 40x12

ART. M4R20P
4 trous - Ø20
H. 1200 - 40x12



LISSE

ART. M3R14P
3 trous - Ø14
H. 1200 - 40x12

ART. M3R16P
3 trous - Ø16
H. 1200 - 40x12

ART. M3R20P
3 trous - Ø20
H. 1200 - 40x12



LISSE

ART. M2R14P
2 trous - Ø14
H. 1200 - 40x12

ART. M2R16P
2 trous - Ø16
H. 1200 - 40x12

ART. M2R20P
2 trous - Ø20
H. 1200 - 40x12

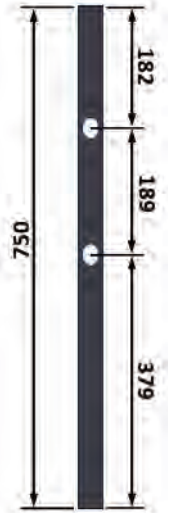

LISSE

ART. M2R14PH750
2 trous - Ø14
H. 750 - 40x12

ART. M2R16PH750
2 trous - Ø16
H. 750 - 40x12

ART. M2R20PH750
2 trous - Ø20
H. 750 - 40x12

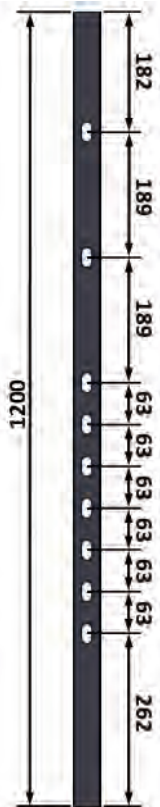

LISSE

ART. M9R14P
9 trous - Ø14
H. 1200 - 40x12



LISSE

ART. M12R8P
12 trous - Ø8
H. 1200 - 40x12

Cotes de perçages

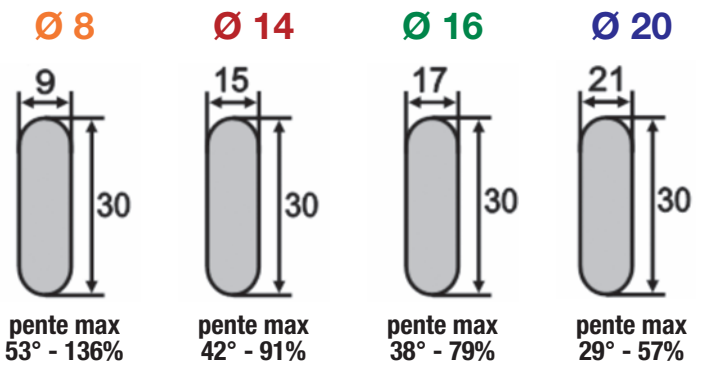

PLATINES DE FIXATION

Pose au sol

Pose en façade

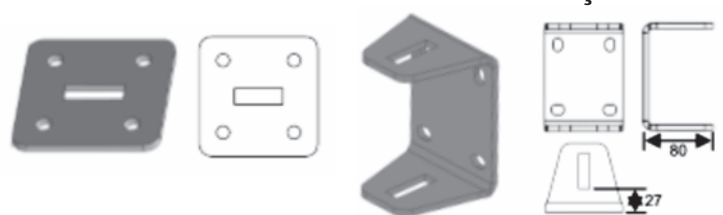

LISSE

ART. PM1
H. 100 - L. 100
Ep. 6 - 4 Trous Ø 11
Passage 40x12

LISSE

ART. SM1
H. 122 - L. 90
Ep. 6 - 4 Trous Ø 11
Passage 40x12

Montants à trous poinçonnés carrés

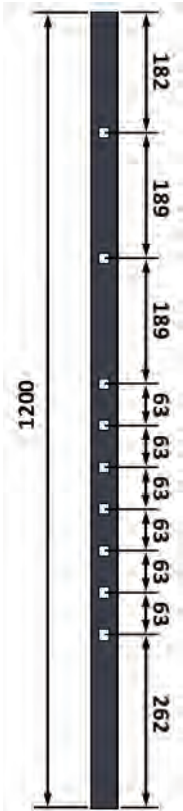

LISSE

ART. M9C14
9 trous - □14
H. 1200 - 40x12

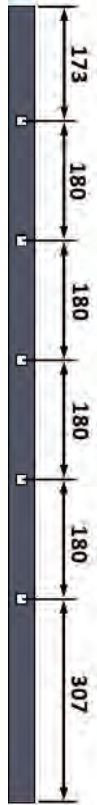

LISSE

ART. M5C14
5 trous - □14
H. 1200 - 40x12



LISSE

ART. M4C14
4 trous - □14
H. 1200 - 40x12



LISSE

ART. M3C14
3 trous - □14
H. 1200 - 40x12



LISSE

ART. M2C14
2 trous - □14
H. 1200 - 40x12

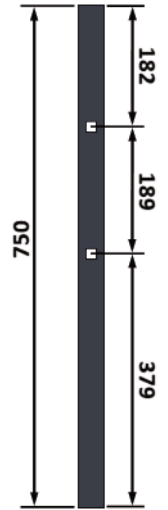

LISSE

ART. M2C14H750
2 trous - □14
H. 750 - 40x12

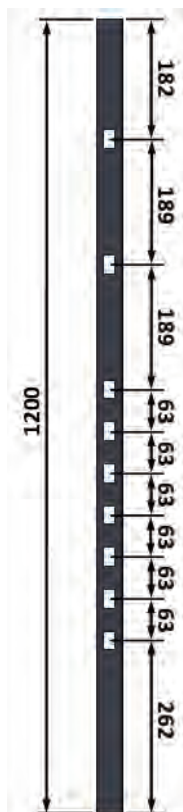

LISSE

ART. M9C14P
9 trous - □14
H. 1200 - 40x12

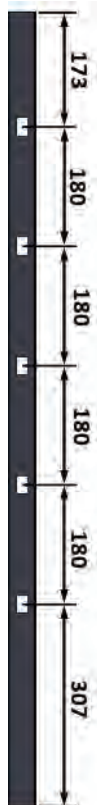

LISSE

ART. M5C14P
5 trous - □14
H. 1200 - 40x12



LISSE

ART. M4C14P
4 trous - □14
H. 1200 - 40x12



LISSE

ART. M3C14P
3 trous - □14
H. 1200 - 40x12



LISSE

ART. M2C14P
2 trous - □14
H. 1200 - 40x12

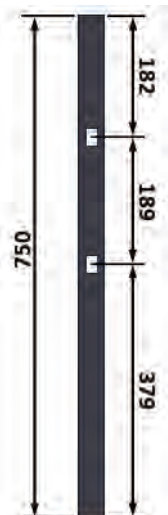

LISSE

ART. M2C14PH750
2 trous - □14
H. 750 - 40x12

Cotes de perçages

□ 14

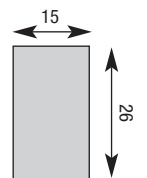

penne max 35° - 72%

CROSSES ET COUDES

MAINS-COURANTES LAMINÉES DE 40

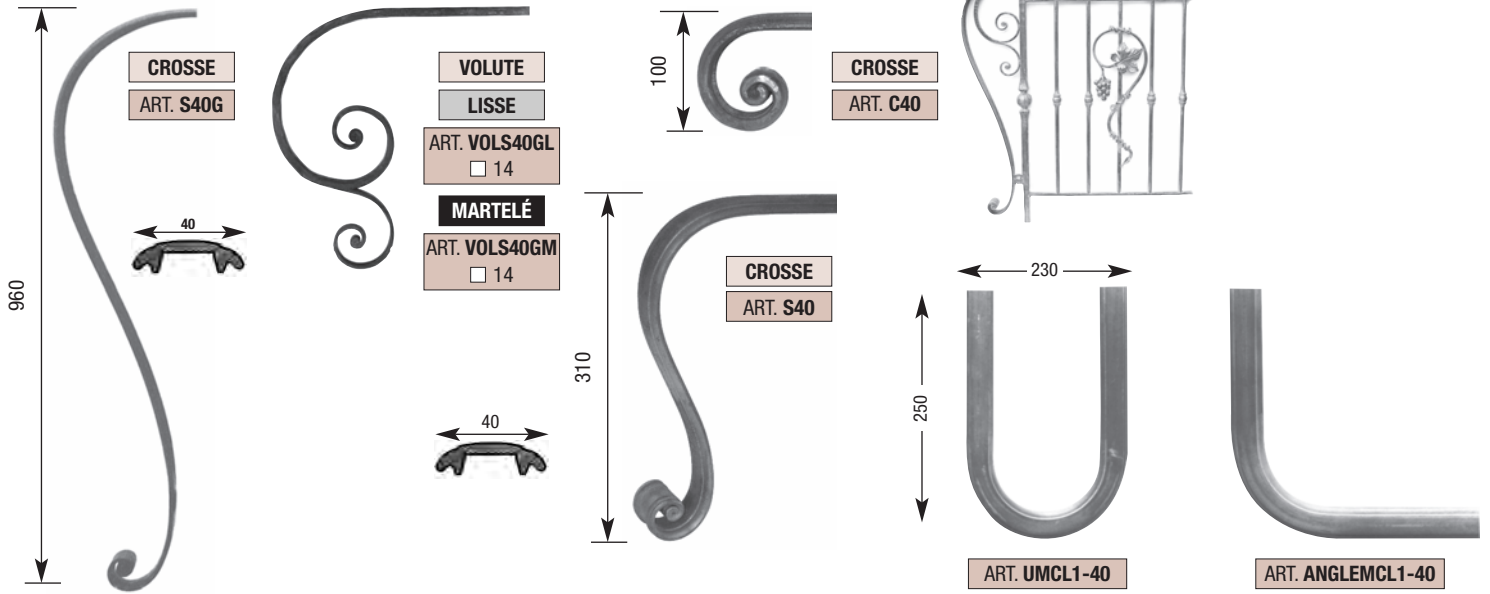

MAINS-COURANTES LAMINÉES DE 45

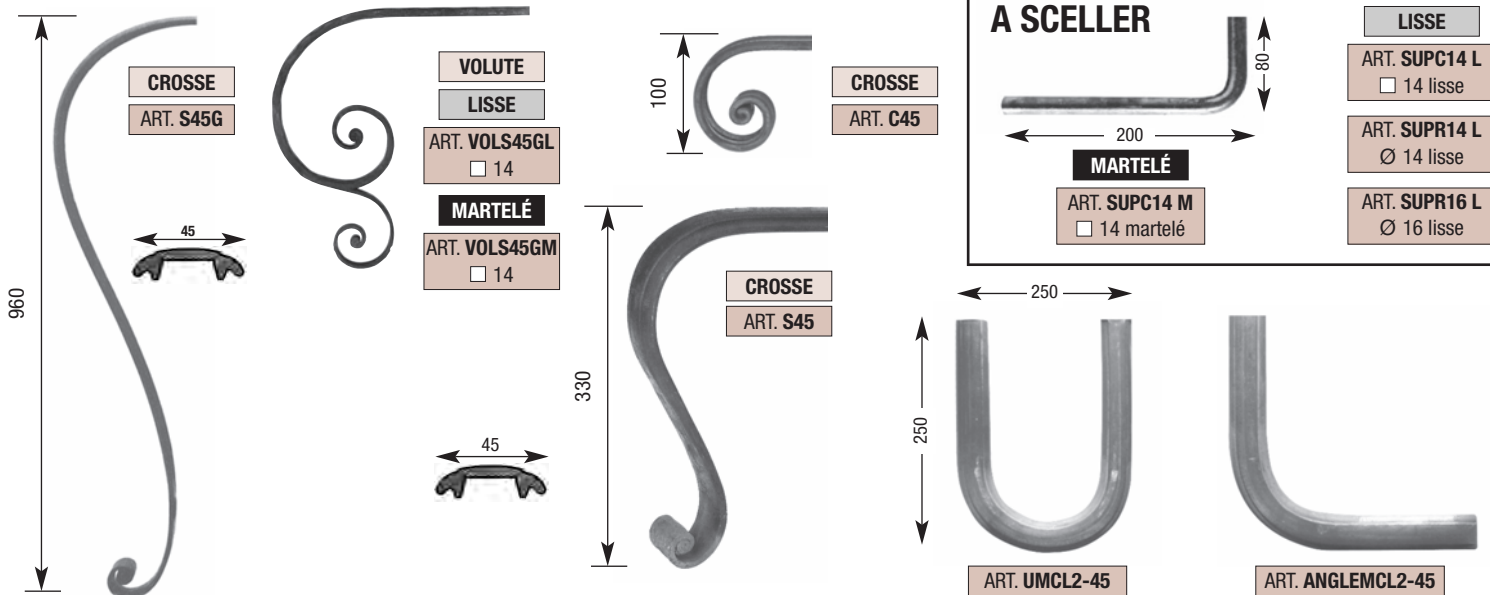

CROSSES ET COUDES EN FER ROND

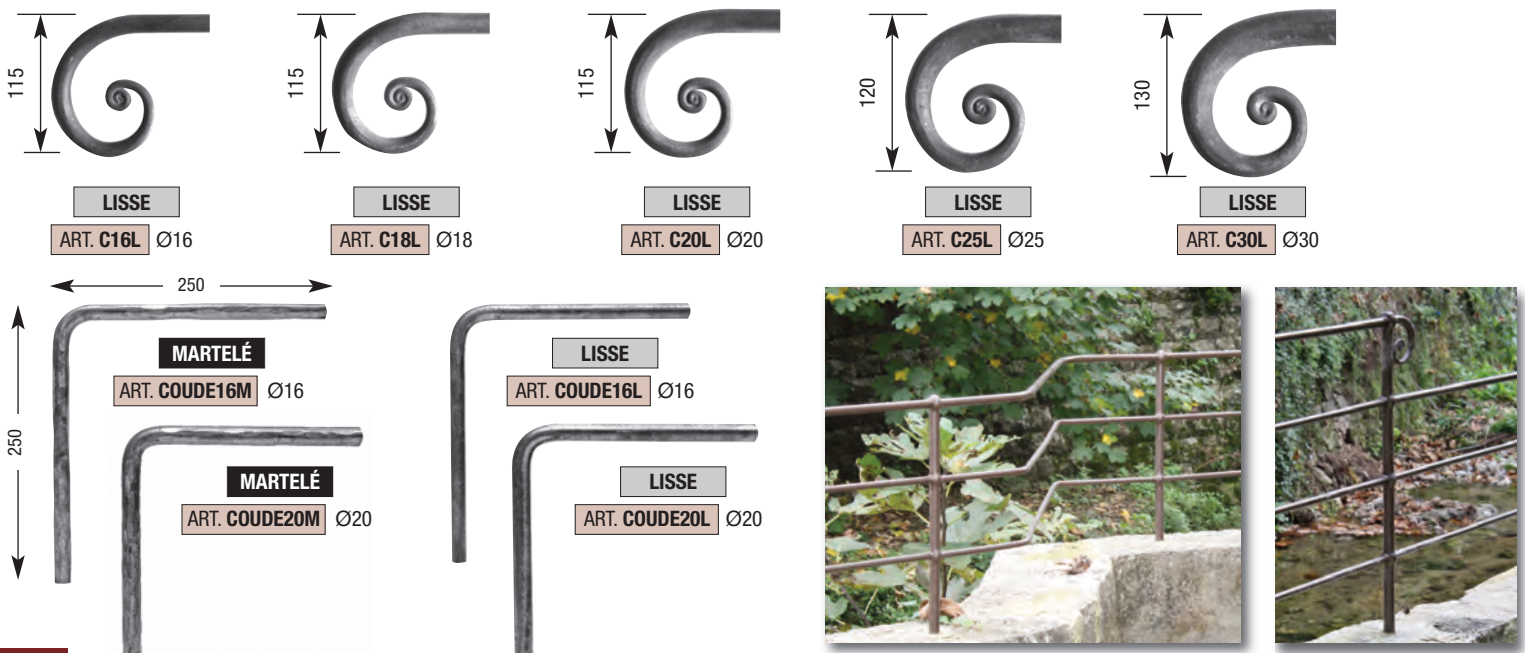

MAIN-COURANTES LAMINÉES



- ART. MCL1-40-2000 Largeur 40 H. 2000
- ART. MCL1-40-3000 Largeur 40 H. 3000
- ART. MCL2-45-2000 Largeur 45 H. 2000
- ART. MCL2-45-3000 Largeur 45 H. 3000

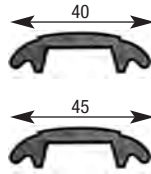

MAIN-COURANTES FORGÉES



- ART. MCF1-45-2000 Largeur 45 H. 2000
- ART. MCF1-55-2000 Largeur 55 H. 2000

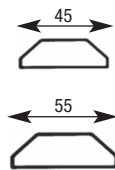

- ART. MCF2-35-2000 Largeur 35 H. 2000
- ART. MCF2-45-2000 Largeur 45 H. 2000



LIENS FORGÉS



- ART. LIEN 1-28-1000 Largeur 28 H. 1000
- ART. LIEN 2-20-1000 Largeur 20 H. 1000
- ART. LIEN 3-17-1000 Largeur 17 H. 1000

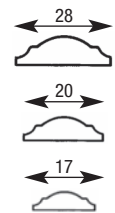

COLLIERS



- ART. COL1 □14x6 + □14 + □14x6
- ART. COL2 □14 + □14x6
- ART. COL3 □14x6 + □14x6
- ART. COL4 □20x6 + □20x6

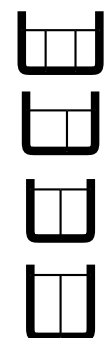

DEMI ROND



- ART. DR20X10 H. 3000
- ART. DR30X15 H. 3000
- ART. DR40X20 H. 3000
- ART. DR50X25 H. 3000

MAIN-COURANTES MOULURÉES



- ART. MCM45X12 H. 3000
- ART. MCM50X14 H. 3000

MOULURES D'ANGLES



- ART. MA261AC 40 x 12 - H. 3000

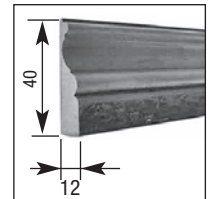

MAIN-COURANTES LAITON largeur 45 mm

PROFIL N°15

- ART. MCL15 Largeur 45 - H. 4500 environ

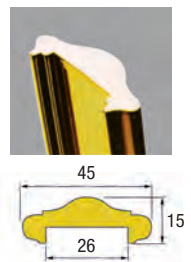

CROSSES LAITON main-courante largeur 45 mm

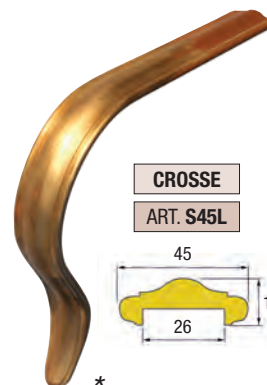

- CROSSE
- ART. S45L

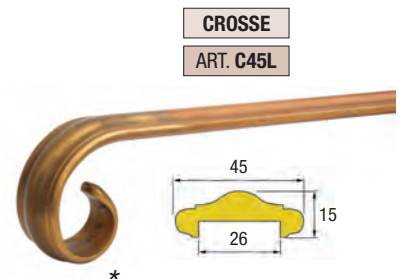
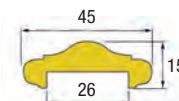

- CROSSE
- ART. C45L

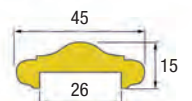

FER CARRE MARTELE



ART. CM14B-910	□ 14 X 14	H. 910
ART. CM14-1200	□ 14 X 14	H. 1200
ART. CM14-2000	□ 14 X 14	H. 2000
ART. CM16-2000	□ 16 X 16	H. 2000
ART. CM18-2000	□ 18 X 18	H. 2000
ART. CM20-2000	□ 20 X 20	H. 2000
ART. CM25-1200	□ 25 X 25	H. 1200
ART. CM25-1500	□ 25 X 25	H. 1500
ART. CM25-2000	□ 25 X 25	H. 2000
ART. CM25T	□ 25 X 25	H. 2500
ART. CM25-3000	□ 25 X 25	H. 3000
ART. CM30-2000	□ 30 X 30	H. 2000
ART. CM30T	□ 30 X 30	H. 2500
ART. CM30-3000	□ 30 X 30	H. 3000
ART. CM35-2000	□ 35 X 35	H. 2000
ART. CM40-2000	□ 40 X 40	H. 2000



FER CARRÉ LISSE

ART. CL14B-910	□ 14 X 14	H. 910
ART. CL14-1200	□ 14 X 14	H. 1200
ART. CL14-2000	□ 14 X 14	H. 2000
ART. CL16-2000	□ 16 X 16	H. 2000
ART. CL18-2000	□ 18 X 18	H. 2000
ART. CL20-2000	□ 20 X 20	H. 2000
ART. CL25-1200	□ 25 X 25	H. 1200
ART. CL25-1500	□ 25 X 25	H. 1500
ART. CL25-2000	□ 25 X 25	H. 2000
ART. CL25T	□ 25 X 25	H. 2500
ART. CL25-3000	□ 25 X 25	H. 3000
ART. CL30-2000	□ 30 X 30	H. 2000
ART. CL30T	□ 30 X 30	H. 2500
ART. CL30-3000	□ 30 X 30	H. 3000
ART. CL35-2000	□ 35 X 35	H. 2000
ART. CL40-2000	□ 40 X 40	H. 2000

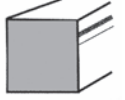

FER ROND MARTELE



ART. RM14B-910	∅ 14	H. 910
ART. RM14-1200	∅ 14	H. 1200
ART. RM14-2000	∅ 14	H. 2000
ART. RM16-2000	∅ 16	H. 2000
ART. RM18-2000	∅ 18	H. 2000
ART. RM20-2000	∅ 20	H. 2000
ART. RM25-2000	∅ 25	H. 2000
ART. RM30-2000	∅ 30	H. 2000



FER ROND LISSE

ART. RL14B-910	∅ 14	H. 910
ART. RL14-1200	∅ 14	H. 1200
ART. RL14-2000	∅ 14	H. 2000
ART. RL16-2000	∅ 16	H. 2000
ART. RL18-2000	∅ 18	H. 2000
ART. RL20-2000	∅ 20	H. 2000
ART. RL25-2000	∅ 25	H. 2000
ART. RL30-2000	∅ 30	H. 2000

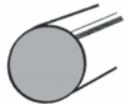

FER PLAT MARTELE



ART. PM40X6	□ 40 X 6	H. 2000
ART. PM50X6	□ 50 X 6	H. 2000



FER PLAT MARTELE



ART. PM20X10	20 X 10	H. 2000
ART. PM30X15	30 X 15	H. 2000
ART. PM30X20	30 X 20	H. 2000
ART. PM35X15	35 X 15	H. 2000
ART. PM35X20	35 X 20	H. 2000
ART. PM40X15	40 X 15	H. 2000
ART. PM40X20	40 X 20	H. 2000

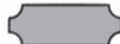

FER PLAT LISSE

ART. PL20X10	20 X 10	H. 2000
ART. PL30X15	30 X 15	H. 2000
ART. PL30X20	30 X 20	H. 2000
ART. PL35X15	35 X 15	H. 2000
ART. PL35X20	35 X 20	H. 2000
ART. PL40X6	40 X 6	H. 2000
ART. PL40X10	40 X 10	H. 2000
ART. PL40X15	40 X 15	H. 2000
ART. PL40X20	40 X 20	H. 2000
ART. PL50X6	50 X 6	H. 2000

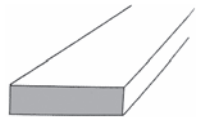

TUBE MARTELE *sur commande*

ART. TM100X40	□ 100X40X2,5	L. 6000
ART. TM100X50	□ 100X50X3	L. 6000
ART. TM50X50	□ 50X50X2,5	L. 6000
ART. TM50X30	□ 50X30X2,5	L. 6000
ART. TM40X40-6	□ 40X40X2,5	L. 6000
ART. TM40X40-3	□ 40X40X2,5	L. 3000
ART. TM40X40-2	□ 40X40X2,5	L. 2000
ART. TM40X20-6	□ 40X20X2	L. 6000
ART. TM40X20-3	□ 40X20X2	L. 3000
ART. TM40X20-2	□ 40X20X2	L. 2000
ART. TM30X30-6	□ 30X30X2,5	L. 6000
ART. TM30X30-3	□ 30X30X2,5	L. 3000
ART. TM30X30-2	□ 30X30X2,5	L. 2000
ART. TM30X20-6	□ 30X20X2	L. 6000
ART. TM30X20-3	□ 30X20X2	L. 3000
ART. TM30X20-2	□ 30X20X2	L. 2000

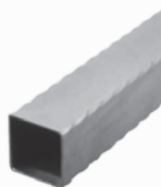

TUBE LISSE

ART. TL100X40	□ 100X40X2,5	L. 6000
ART. TL100X50	□ 100X50X2,5	L. 6000
ART. TL50X50	□ 50X50X2,5	L. 6000
ART. TL50X30	□ 50X30X2,5	L. 6000
ART. TL40X40-6	□ 40X40X2	L. 6000
ART. TL40X40-3	□ 40X40X2	L. 3000
ART. TL40X40-2	□ 40X40X2	L. 2000
ART. TL40X20-6	□ 40X20X2	L. 6000
ART. TL40X20-3	□ 40X20X2	L. 3000
ART. TL40X20-2	□ 40X20X2	L. 2000
ART. TL30X30-6	□ 30X30X2,5	L. 6000
ART. TL30X30-3	□ 30X30X2,5	L. 3000
ART. TL30X30-2	□ 30X30X2,5	L. 2000
ART. TL30X20-6	□ 30X20X2	L. 6000
ART. TL30X20-3	□ 30X20X2	L. 3000
ART. TL30X20-2	□ 30X20X2	L. 2000

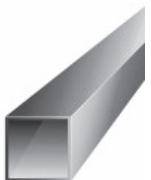

TRAVERSES A TROUS RENFLÉS A CHAUD

Hauteur 2000

Vide 110

Possibilité de fabriquer vos traverses avec section, entraxe et longueur à la demande. Nous consulter.

LISSE	ART. TR1-14L	□ 14	TROU ◇ 14 Diag.	14 TROUS	LISSE	ART. TR1-18L	□ 18	TROU ◇ 18 Diag.	14 TROUS
LISSE	ART. TR1-16L	□ 16	TROU ◇ 16 Diag.	14 TROUS	LISSE	ART. TR1-20L	□ 20	TROU ◇ 20 Diag.	13 TROUS
LISSE	ART. TR1-16-14L	□ 16	TROU ◇ 14 Diag.	14 TROUS	LISSE	ART. TR1-25L	□ 25	TROU ◇ 25 Diag.	12 TROUS
Percé Perc M12									
LISSE	ART. TR2-16L	□ 16	TROU ◇ 16-ARETTE	14 TROUS	LISSE	ART. TR2-20L	□ 20	TROU ◇ 20-ARETTE	13 TROUS
LISSE	ART. TR3-14L	□ 14	TROU □ 14	15 TROUS	LISSE	ART. TR3-18L	□ 18	TROU □ 18	14 TROUS
LISSE	ART. TR3-16L	□ 16	TROU □ 16	15 TROUS	LISSE	ART. TR3-20L	□ 20	TROU □ 20	13 TROUS
LISSE	ART. TR4-14L	∅ 14	TROU ∅ 14	15 TROUS	LISSE	ART. TR4-20L	∅ 20	TROU ∅ 20	13 TROUS
LISSE	ART. TR4-16L	∅ 16	TROU ∅ 16	15 TROUS	LISSE	ART. TR4-25L	∅ 25	TROU ∅ 25	12 TROUS
LISSE	ART. TR4-18L	∅ 18	TROU ∅ 18	14 TROUS					
LISSE	ART. TR5-18L	35 X 15	TROU ◇ 18 Diag.	14 TROUS	LISSE	ART. TR11-20L	35 X 15	TROU ∅ 20	14 TROUS
LISSE	ART. TR5-20L	35 X 15	TROU ◇ 20 Diag.	13 TROUS					

TRAVERSES A TROUS RENFLÉS A CHAUD SUR MESURE

■ 20 x 20 - TROU PASS. ◇ 20 DIAG.

LISSE	ART. TR1-20-40	TABLEAU 400	2 TROUS	VIDE 11,5
LISSE	ART. TR1-20-50	TABLEAU 500	3 TROUS	VIDE 11,7
LISSE	ART. TR1-20-60	TABLEAU 600	3 TROUS	VIDE 13,2
LISSE	ART. TR1-20-70	TABLEAU 700	4 TROUS	VIDE 12,0
LISSE	ART. TR1-20-80	TABLEAU 800	5 TROUS	VIDE 11,2
LISSE	ART. TR1-20-90	TABLEAU 900	5 TROUS	VIDE 12,8
LISSE	ART. TR1-20-100	TABLEAU 1000	6 TROUS	VIDE 12,0
LISSE	ART. TR1-20-110	TABLEAU 1100	7 TROUS	VIDE 11,3
LISSE	ART. TR1-20-120	TABLEAU 1200	7 TROUS	VIDE 12,5
LISSE	ART. TR1-20-130	TABLEAU 1300	8 TROUS	VIDE 12,0
LISSE	ART. TR1-20-140	TABLEAU 1400	9 TROUS	VIDE 11,7
LISSE	ART. TR1-20-150	TABLEAU 1500	10 TROUS	VIDE 11,3

TRAVERSES POINÇONNÉES 40 x 10 - Hauteur 2000 - Vide 110



- LISSE** ART. TR6-14 TROU □ 14 - 15 TROUS
- LISSE** ART. TR6-16 TROU □ 16 - 15 TROUS
- LISSE** ART. TR6-18 TROU □ 18 - 14 TROUS
- LISSE** ART. TR6-20 TROU □ 20 - 14 TROUS
- 40 x 10

- LISSE** ART. TR7-14 TROU ◇ 14 - 14 TROUS
- LISSE** ART. TR7-16 TROU ◇ 16 - 14 TROUS
- LISSE** ART. TR7-18 TROU ◇ 18 - 14 TROUS
- LISSE** ART. TR7-20 TROU ◇ 20 - 14 TROUS
- 40 x 10

- LISSE** ART. TR8-14 TROU ∅ 14 - 15 TROUS
- LISSE** ART. TR8-16 TROU ∅ 16 - 15 TROUS
- LISSE** ART. TR8-18 TROU ∅ 18 - 14 TROUS
- LISSE** ART. TR8-20 TROU ∅ 20 - 14 TROUS
- 40 x 10

TROUS OVALES



- LISSE** ART. TR8-16-OV 15 TROUS
- 40 x 10

TROUS RECTANGLES



- LISSE** ART. TR6-16-RECT 15 TROUS
- 40 x 10

TRAVERSES POINÇONNÉES 25 x 10 - Hauteur 2000 - Vide 110



- LISSE** ART. TR9-14 TROU ∅ 14 - 15 TROUS
- 25 x 10

TRAVERSES POINÇONNÉES 25 x 10 - Hauteur 2000 - Vide 100



- LISSE** ART. TR10-14 TROU ∅ 14 - 16 TROUS
- 25 x 10

FERS PLATS 40 x 6 avec empreintes - Hauteur 2000



- LISSE** ART. TR11EMP EMPREINTES CARRÉES
- 40 x 6



- MART.** ART. TR12EMP EMPREINTES CARRÉES
- 40 x 6





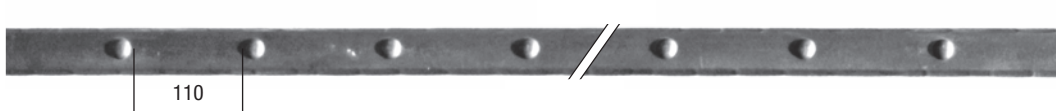









- LISSE** ART. TR13EMP EMPREINTES RONDES
- 40 x 6















- MART.** ART. TR14EMP EMPREINTES RONDES
- 40 x 6

TRAVERSES POINÇONNÉES 30x8 SUR MESURE - Trous Ø 14

	LISSE	ART. TR8-14-40	TABLEAU 400	2 TROUS	VIDE 12,2
	LISSE	ART. TR8-14-50	TABLEAU 500	3 TROUS	VIDE 11,3
	LISSE	ART. TR8-14-60	TABLEAU 600	4 TROUS	VIDE 10,8
	LISSE	ART. TR8-14-70	TABLEAU 700	5 TROUS	VIDE 10,4
	LISSE	ART. TR8-14-80	TABLEAU 800	5 TROUS	VIDE 12,2
	LISSE	ART. TR8-14-90	TABLEAU 900	6 TROUS	VIDE 11,6
	LISSE	ART. TR8-14-100	TABLEAU 1000	7 TROUS	VIDE 11,2
	LISSE	ART. TR8-14-110	TABLEAU 1100	8 TROUS	VIDE 11,0
	LISSE	ART. TR8-14-120	TABLEAU 1200	8 TROUS	VIDE 12,0
	LISSE	ART. TR8-14-130	TABLEAU 1300	9 TROUS	VIDE 11,5
	LISSE	ART. TR8-14-140	TABLEAU 1400	10 TROUS	VIDE 11,5
	LISSE	ART. TR8-14-150	TABLEAU 1500	11 TROUS	VIDE 11,2

TRAVERSES POINÇONNÉES 35x8 SUR MESURE - Trous ◆ 14 Diag.

	LISSE	ART. TR7-14-40	TABLEAU 400	2 TROUS	VIDE 11,5
	LISSE	ART. TR7-14-50	TABLEAU 500	3 TROUS	VIDE 10,7
	LISSE	ART. TR7-14-60	TABLEAU 600	4 TROUS	VIDE 10,3
	LISSE	ART. TR7-14-70	TABLEAU 700	5 TROUS	VIDE 9,7
	LISSE	ART. TR7-14-80	TABLEAU 800	5 TROUS	VIDE 11,6
	LISSE	ART. TR7-14-90	TABLEAU 900	6 TROUS	VIDE 11,2
	LISSE	ART. TR7-14-100	TABLEAU 1000	7 TROUS	VIDE 10,8
	LISSE	ART. TR7-14-110	TABLEAU 1100	8 TROUS	VIDE 10,4
	LISSE	ART. TR7-14-120	TABLEAU 1200	8 TROUS	VIDE 11,4
	LISSE	ART. TR7-14-130	TABLEAU 1300	9 TROUS	VIDE 11,2
	LISSE	ART. TR7-14-140	TABLEAU 1400	10 TROUS	VIDE 10,7
	LISSE	ART. TR7-14-150	TABLEAU 1500	11 TROUS	VIDE 10,8

LISSE Ø 14 - Ø 16 - Ø 18 - Ø 20

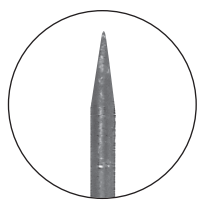

LISSE	LISSE	LISSE	LISSE	LISSE	LISSE
ART. P1RL14 H. 200 - Ø 14	ART. 1RL14-500 H. 500 - Ø 14	ART. 1RL14-1000 H. 1000 - Ø 14	ART. 1RL14-1200 H. 1200 - Ø 14	ART. 1RL14-1500 H. 1500 - Ø 14	ART. 1RL14-2000 H. 2000 - Ø 14
ART. P1RL16 H. 200 - Ø 16		ART. 1RL16-1000 H. 1000 - Ø 16	ART. 1RL16-1200 H. 1200 - Ø 16	ART. 1RL16-1500 H. 1500 - Ø 16	ART. 1RL16-2000 H. 2000 - Ø 16
ART. P1RL18 H. 200 - Ø 18		ART. 1RL18-1000 H. 1000 - Ø 18	ART. 1RL18-1200 H. 1200 - Ø 18	ART. 1RL18-1500 H. 1500 - Ø 18	ART. 1RL18-2000 H. 2000 - Ø 18
ART. P1RL20 H. 200 - Ø 20		ART. 1RL20-1000 H. 1000 - Ø 20	ART. 1RL20-1200 H. 1200 - Ø 20	ART. 1RL20-1500 H. 1500 - Ø 20	ART. 1RL20-2000 H. 2000 - Ø 20

LISSE Ø 14 - Ø 16 - Ø 18 - Ø 20

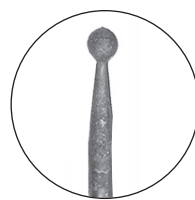

LISSE	LISSE	LISSE	LISSE
ART. P2RL14 H. 200 - Ø 14	ART. 2RL14-1000 H. 1000 - Ø 14	ART. 2RL14-1200 H. 1200 - Ø 14	ART. 2RL14-1500 H. 1500 - Ø 14
ART. P2RL16 H. 200 - Ø 16	ART. 2RL16-1000 H. 1000 - Ø 16	ART. 2RL16-1200 H. 1200 - Ø 16	ART. 2RL16-1500 H. 1500 - Ø 16
ART. P2RL18 H. 200 - Ø 18	ART. 2RL18-1000 H. 1000 - Ø 18	ART. 2RL18-1200 H. 1200 - Ø 18	ART. 2RL18-1500 H. 1500 - Ø 18
ART. P2RL20 H. 200 - Ø 20	ART. 2RL20-1000 H. 1000 - Ø 20	ART. 2RL20-1200 H. 1200 - Ø 20	ART. 2RL20-1500 H. 1500 - Ø 20

LISSE Ø 16

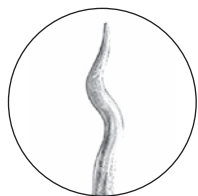

LISSE	LISSE	LISSE	LISSE
ART. P1SRL16 H. 200 - Ø 16	ART. 1SRL16-1000 H. 1000 - Ø 16	ART. 1SRL16-1200 H. 1200 - Ø 16	ART. 1SRL16-1500 H. 1500 - Ø 16

LISSE Ø 16

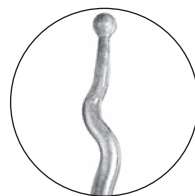

LISSE	LISSE	LISSE	LISSE
ART. P1SRLB16 H. 200 - Ø 16	ART. 1SRLB16-1000 H. 1000 - Ø 16	ART. 1SRLB16-1200 H. 1200 - Ø 16	ART. 1SRLB16-1500 H. 1500 - Ø 16

BARREAUX FORGÉS LISSES

Possibilité de hauteur et section sur commande

LISSE Ø 14 - Ø 16 - Ø 18 - Ø 20



LISSE	LISSE	LISSE	LISSE	LISSE
ART. P9RL14 H. 200 - Ø 14	ART. 9RL14-1000 H. 1000 - Ø 14	ART. 9RL14-1200 H. 1200 - Ø 14	ART. 9RL14-1500 H. 1500 - Ø 14	ART. 9RL14-2000 H. 2000 - Ø 14
ART. P9RL16 H. 200 - Ø 16	ART. 9RL16-1000 H. 1000 - Ø 16	ART. 9RL16-1200 H. 1200 - Ø 16	ART. 9RL16-1500 H. 1500 - Ø 16	ART. 9RL16-2000 H. 2000 - Ø 16
ART. P9RL18 H. 200 - Ø 18	ART. 9RL18-1000 H. 1000 - Ø 18	ART. 9RL18-1200 H. 1200 - Ø 18	ART. 9RL18-1500 H. 1500 - Ø 18	ART. 9RL18-2000 H. 2000 - Ø 18
ART. P9RL20 H. 200 - Ø 20	ART. 9RL20-1000 H. 1000 - Ø 20	ART. 9RL20-1200 H. 1200 - Ø 20	ART. 9RL20-1500 H. 1500 - Ø 20	ART. 9RL20-2000 H. 2000 - Ø 20

LISSE Ø 16

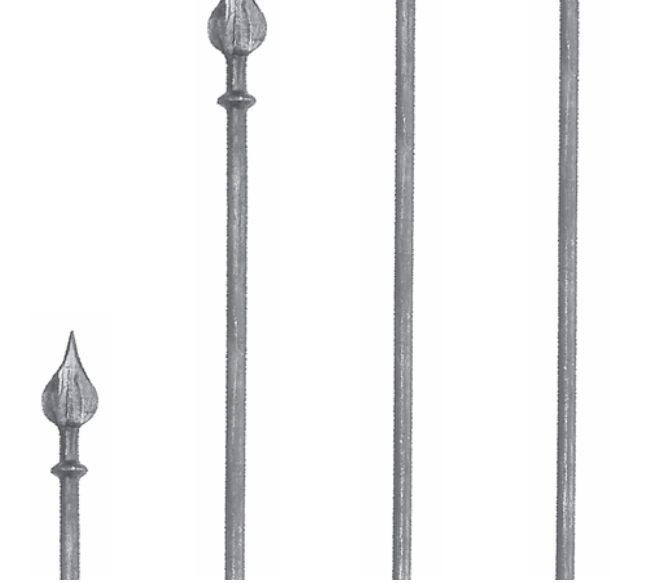
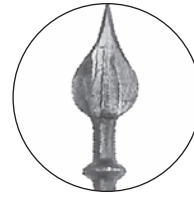

LISSE	LISSE	LISSE	LISSE
ART. P4RL16 H. 200 - Ø 16	ART. 4RL16-1000 H. 1000 - Ø 16	ART. 4RL16-1200 H. 1200 - Ø 16	ART. 4RL16-1500 H. 1500 - Ø 16

LISSE Ø 16

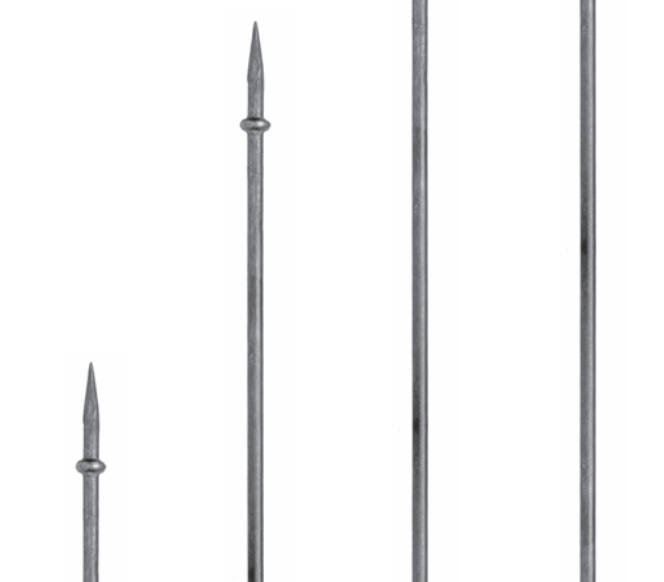

LISSE	LISSE	LISSE	LISSE
ART. P3RL16 H. 200 - Ø 16	ART. 3RL16-1000 H. 1000 - Ø 16	ART. 3RL16-1200 H. 1200 - Ø 16	ART. 3RL16-1500 H. 1500 - Ø 16

LISSE Ø 14 - Ø 16



LISSE	LISSE	LISSE	LISSE	LISSE
ART. P18RL14 H. 200 - Ø 14	ART. 18RL14-1000 H. 1000 - Ø 14	ART. 18RL14-1200 H. 1200 - Ø 14	ART. 18RL14-1500 H. 1500 - Ø 14	
ART. P18RL16 H. 200 - Ø 16	ART. 18RL16-1000 H. 1000 - Ø 16	ART. 18RL16-1200 H. 1200 - Ø 16	ART. 18RL16-1500 H. 1500 - Ø 16	ART. 19RL16-1500 H. 1500 - Ø 16

MARTELÉ 14 - 16 - 18 - 20



MARTELÉ	MARTELÉ	MARTELÉ	MARTELÉ	MARTELÉ	MARTELÉ
ART. P1CM14 H. 200 - <input type="checkbox"/> 14	ART. 1CM14-500 H. 500 - <input type="checkbox"/> 14	ART. 1CM14-1000 H. 1000 - <input type="checkbox"/> 14	ART. 1CM14-1200 H. 1200 - <input type="checkbox"/> 14	ART. 1CM14-1500 H. 1500 - <input type="checkbox"/> 14	ART. 1CM14-2000 H. 2000 - <input type="checkbox"/> 14
ART. P1CM16 H. 200 - <input type="checkbox"/> 16		ART. 1CM16-1000 H. 1000 - <input type="checkbox"/> 16	ART. 1CM16-1200 H. 1200 - <input type="checkbox"/> 16	ART. 1CM16-1500 H. 1500 - <input type="checkbox"/> 16	ART. 1CM16-2000 H. 2000 - <input type="checkbox"/> 16
ART. P1CM18 H. 200 - <input type="checkbox"/> 18		ART. 1CM18-1000 H. 1000 - <input type="checkbox"/> 18	ART. 1CM18-1200 H. 1200 - <input type="checkbox"/> 18	ART. 1CM18-1500 H. 1500 - <input type="checkbox"/> 18	ART. 1CM18-2000 H. 2000 - <input type="checkbox"/> 18
ART. P1CM20 H. 200 - <input type="checkbox"/> 20		ART. 1CM20-1000 H. 1000 - <input type="checkbox"/> 20	ART. 1CM20-1200 H. 1200 - <input type="checkbox"/> 20	ART. 1CM20-1500 H. 1500 - <input type="checkbox"/> 20	ART. 1CM20-2000 H. 2000 - <input type="checkbox"/> 20

MARTELÉ 14 - 16 - 18 - 20

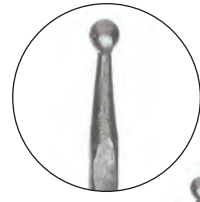

MARTELÉ	MARTELÉ	MARTELÉ	MARTELÉ
ART. P2CM14 H. 200 - <input type="checkbox"/> 14	ART. 2CM14-1000 H. 1000 - <input type="checkbox"/> 14	ART. 2CM14-1200 H. 1200 - <input type="checkbox"/> 14	ART. 2CM14-1500 H. 1500 - <input type="checkbox"/> 14
ART. P2CM16 H. 200 - <input type="checkbox"/> 16	ART. 2CM16-1000 H. 1000 - <input type="checkbox"/> 16	ART. 2CM16-1200 H. 1200 - <input type="checkbox"/> 16	ART. 2CM16-1500 H. 1500 - <input type="checkbox"/> 16
ART. P2CM18 H. 200 - <input type="checkbox"/> 18	ART. 2CM18-1000 H. 1000 - <input type="checkbox"/> 18	ART. 2CM18-1200 H. 1200 - <input type="checkbox"/> 18	ART. 2CM18-1500 H. 1500 - <input type="checkbox"/> 18
ART. P2CM20 H. 200 - <input type="checkbox"/> 20	ART. 2CM20-1000 H. 1000 - <input type="checkbox"/> 20	ART. 2CM20-1200 H. 1200 - <input type="checkbox"/> 20	ART. 2CM20-1500 H. 1500 - <input type="checkbox"/> 20

MARTELÉ 14 - 16



MARTELÉ	MARTELÉ	MARTELÉ	MARTELÉ
ART. P1SM14 H. 200 - <input type="checkbox"/> 14			
ART. P1SM16 H. 200 - <input type="checkbox"/> 16			
ART. P1SM18 H. 200 - <input type="checkbox"/> 18			
ART. P1SM20 H. 200 - <input type="checkbox"/> 20			
	ART. 1SM14-1000 H. 1000 - <input type="checkbox"/> 14	ART. 1SM14-1200 H. 1200 - <input type="checkbox"/> 14	ART. 1SM14-1500 H. 1500 - <input type="checkbox"/> 14
	ART. 1SM16-1000 H. 1000 - <input type="checkbox"/> 16	ART. 1SM16-1200 H. 1200 - <input type="checkbox"/> 16	ART. 1SM16-1500 H. 1500 - <input type="checkbox"/> 16

MARTELÉ 16



MARTELÉ	MARTELÉ
ART. P1SMB14 H. 200 - <input type="checkbox"/> 14	
ART. P1SMB16 H. 200 - <input type="checkbox"/> 16	
ART. P1SMB18 H. 200 - <input type="checkbox"/> 18	
ART. P1SMB20 H. 200 - <input type="checkbox"/> 20	
	ART. 1SMB16-1500 H. 1500 - <input type="checkbox"/> 16

MARTELÉ 16

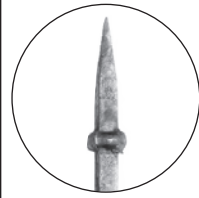

MARTELÉ	MARTELÉ	MARTELÉ	MARTELÉ
ART. P3CM16 H. 200 - <input type="checkbox"/> 16			
	ART. 3CM16-1000 H. 1000 - <input type="checkbox"/> 16	ART. 3CM16-1200 H. 1200 - <input type="checkbox"/> 16	ART. 3CM16-1500 H. 1500 - <input type="checkbox"/> 16

LISSE □ 14 - □ 16 - □ 18 - □ 20



LISSE	LISSE	LISSE	LISSE	LISSE	LISSE
ART. P1CL14 H. 200 - □ 14	ART. 1CL14-500 H. 500 - □ 14	ART. 1CL14-1000 H. 1000 - □ 14	ART. 1CL14-1200 H. 1200 - □ 14	ART. 1CL14-1500 H. 1500 - □ 14	ART. 1CL14-2000 H. 2000 - □ 14
ART. P1CL16 H. 200 - □ 16		ART. 1CL16-1000 H. 1000 - □ 16	ART. 1CL16-1200 H. 1200 - □ 16	ART. 1CL16-1500 H. 1500 - □ 16	ART. 1CL16-2000 H. 2000 - □ 16
ART. P1CL18 H. 200 - □ 18		ART. 1CL18-1000 H. 1000 - □ 18	ART. 1CL18-1200 H. 1200 - □ 18	ART. 1CL18-1500 H. 1500 - □ 18	ART. 1CL18-2000 H. 2000 - □ 18
ART. P1CL20 H. 200 - □ 20		ART. 1CL20-1000 H. 1000 - □ 20	ART. 1CL20-1200 H. 1200 - □ 20	ART. 1CL20-1500 H. 1500 - □ 20	ART. 1CL20-2000 H. 2000 - □ 20

LISSE □ 14 - □ 16 - □ 18 - □ 20

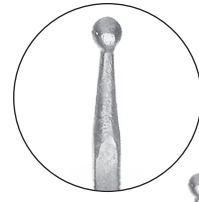

LISSE	LISSE	LISSE	LISSE
ART. P2CL14 H. 200 - □ 14	ART. 2CL14-1000 H. 1000 - □ 14	ART. 2CL14-1200 H. 1200 - □ 14	ART. 2CL14-1500 H. 1500 - □ 14
ART. P2CL16 H. 200 - □ 16	ART. 2CL16-1000 H. 1000 - □ 16	ART. 2CL16-1200 H. 1200 - □ 16	ART. 2CL16-1500 H. 1500 - □ 16
ART. P2CL18 H. 200 - □ 18	ART. 2CL18-1000 H. 1000 - □ 18	ART. 2CL18-1200 H. 1200 - □ 18	ART. 2CL18-1500 H. 1500 - □ 18
ART. P2CL20 H. 200 - □ 20	ART. 2CL20-1000 H. 1000 - □ 20	ART. 2CL20-1200 H. 1200 - □ 20	ART. 2CL20-1500 H. 1500 - □ 20

LISSE □ 14 - □ 16



LISSE	LISSE	LISSE	LISSE
ART. P1SL14 H. 200 - □ 14			
ART. P1SL16 H. 200 - □ 16			
ART. P1SL18 H. 200 - □ 18	ART. 1SL14-1000 H. 1000 - □ 14	ART. 1SL14-1200 H. 1200 - □ 14	ART. 1SL14-1500 H. 1500 - □ 14
ART. P1SL20 H. 200 - □ 20	ART. 1SL16-1000 H. 1000 - □ 16	ART. 1SL16-1200 H. 1200 - □ 16	ART. 1SL16-1500 H. 1500 - □ 16

LISSE □ 16



LISSE	LISSE
ART. P1SLB14 H. 200 - □ 14	
ART. P1SLB16 H. 200 - □ 16	
ART. P1SLB18 H. 200 - □ 18	ART. 1SLB16-1500 H. 1500 - □ 16
ART. P1SLB20 H. 200 - □ 20	

LISSE □ 16



LISSE	LISSE	LISSE	LISSE
ART. P3CL16 H. 200 - □ 16	ART. 3CL16-1000 H. 1000 - □ 16	ART. 3CL16-1200 H. 1200 - □ 16	ART. 3CL16-1500 H. 1500 - □ 16

BARREAUX FORGÉS LISSES ET MARTELÉS

Possibilité de hauteur et section sur commande

LISSE 14 - 16 - 18 - 20

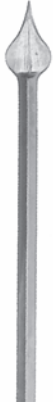
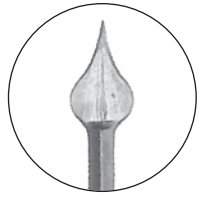

LISSE	LISSE	LISSE	LISSE
ART. P9CLD14 H. 200 - <input type="checkbox"/> 14	ART. 9CLD14-1000 H. 1000 - <input type="checkbox"/> 14	ART. 9CLD14-1200 H. 1200 - <input type="checkbox"/> 14	ART. 9CLD14-1500 H. 1500 - <input type="checkbox"/> 14
ART. P9CLD16 H. 200 - <input type="checkbox"/> 16	ART. 9CLD16-1000 H. 1000 - <input type="checkbox"/> 16	ART. 9CLD16-1200 H. 1200 - <input type="checkbox"/> 16	ART. 9CLD16-1500 H. 1500 - <input type="checkbox"/> 16
ART. P9CLD18 H. 200 - <input type="checkbox"/> 18	ART. 9CLD18-1000 H. 1000 - <input type="checkbox"/> 18	ART. 9CLD18-1200 H. 1200 - <input type="checkbox"/> 18	ART. 9CLD18-1500 H. 1500 - <input type="checkbox"/> 18
ART. P9CLD20 H. 200 - <input type="checkbox"/> 20	ART. 9CLD20-1000 H. 1000 - <input type="checkbox"/> 20	ART. 9CLD20-1200 H. 1200 - <input type="checkbox"/> 20	ART. 9CLD20-1500 H. 1500 - <input type="checkbox"/> 20

MARTELÉ 14 - 16 - 18 - 20



MARTELÉ	MARTELÉ	MARTELÉ	MARTELÉ
ART. P9CMD14 H. 200 - <input type="checkbox"/> 14	ART. 9CMD14-1000 H. 1000 - <input type="checkbox"/> 14	ART. 9CMD14-1200 H. 1200 - <input type="checkbox"/> 14	ART. 9CMD14-1500 H. 1500 - <input type="checkbox"/> 14
ART. P9CMD16 H. 200 - <input type="checkbox"/> 16	ART. 9CMD16-1000 H. 1000 - <input type="checkbox"/> 16	ART. 9CMD16-1200 H. 1200 - <input type="checkbox"/> 16	ART. 9CMD16-1500 H. 1500 - <input type="checkbox"/> 16
ART. P9CMD18 H. 200 - <input type="checkbox"/> 18	ART. 9CMD18-1000 H. 1000 - <input type="checkbox"/> 18	ART. 9CMD18-1200 H. 1200 - <input type="checkbox"/> 18	ART. 9CMD18-1500 H. 1500 - <input type="checkbox"/> 18
ART. P9CMD20 H. 200 - <input type="checkbox"/> 20	ART. 9CMD20-1000 H. 1000 - <input type="checkbox"/> 20	ART. 9CMD20-1200 H. 1200 - <input type="checkbox"/> 20	ART. 9CMD20-1500 H. 1500 - <input type="checkbox"/> 20

LISSE 16



LISSE	LISSE	LISSE	LISSE
ART. P4CL16 H. 200 - <input type="checkbox"/> 16	ART. 4CL16-1000 H. 1000 - <input type="checkbox"/> 16	ART. 4CL16-1200 H. 1200 - <input type="checkbox"/> 16	ART. 4CL16-1500 H. 1500 - <input type="checkbox"/> 16

MARTELÉ 16



MARTELÉ	MARTELÉ	MARTELÉ	MARTELÉ
ART. P4CM16 H. 200 - <input type="checkbox"/> 16	ART. 4CM16-1000 H. 1000 - <input type="checkbox"/> 16	ART. 4CM16-1200 H. 1200 - <input type="checkbox"/> 16	ART. 4CM16-1500 H. 1500 - <input type="checkbox"/> 16

BARREAUX FORGÉS LISSES ET MARTELÉS

Possibilité de hauteur et section sur commande



LISSE □ 14 - □ 16 - □ 18 - □ 20



LISSE	LISSE	LISSE	LISSE
ART. P9CLP14 H. 200 - □ 14	ART. 9CLP14-1000 H. 1000 - □ 14	ART. 9CLP14-1200 H. 1200 - □ 14	ART. 9CLP14-1500 H. 1500 - □ 14
ART. P9CLP16 H. 200 - □ 16	ART. 9CLP16-1000 H. 1000 - □ 16	ART. 9CLP16-1200 H. 1200 - □ 16	ART. 9CLP16-1500 H. 1500 - □ 16
ART. P9CLP18 H. 200 - □ 18	ART. 9CLP18-1000 H. 1000 - □ 18	ART. 9CLP18-1200 H. 1200 - □ 18	ART. 9CLP18-1500 H. 1500 - □ 18
ART. P9CLP20 H. 200 - □ 20	ART. 9CLP20-1000 H. 1000 - □ 20	ART. 9CLP20-1200 H. 1200 - □ 20	ART. 9CLP20-1500 H. 1500 - □ 20

MARTELÉ □ 14 - □ 16 - □ 18 - □ 20



MARTELÉ	MARTELÉ	MARTELÉ	MARTELÉ
ART. P9CMP14 H. 200 - □ 14	ART. 9CMP14-1000 H. 1000 - □ 14	ART. 9CMP14-1200 H. 1200 - □ 14	ART. 9CMP14-1500 H. 1500 - □ 14
ART. P9CMP16 H. 200 - □ 16	ART. 9CMP16-1000 H. 1000 - □ 16	ART. 9CMP16-1200 H. 1200 - □ 16	ART. 9CMP16-1500 H. 1500 - □ 16
ART. P9CMP18 H. 200 - □ 18	ART. 9CMP18-1000 H. 1000 - □ 18	ART. 9CMP18-1200 H. 1200 - □ 18	ART. 9CMP18-1500 H. 1500 - □ 18
ART. P9CMP20 H. 200 - □ 20	ART. 9CMP20-1000 H. 1000 - □ 20	ART. 9CMP20-1200 H. 1200 - □ 20	ART. 9CMP20-1500 H. 1500 - □ 20

* modèle déposé

LISSE ∅ 16

NOUVEAU



LISSE	LISSE	LISSE	LISSE
ART. P5RL16 H. 200 - ∅ 16	ART. 5RL16-1000 H. 1000 - ∅ 16	ART. 5RL16-1200 H. 1200 - ∅ 16	ART. 5RL16-1500 H. 1500 - ∅ 16

LISSE □ 16

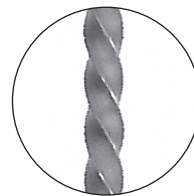

LISSE	LISSE	LISSE
ART. 1CT16-1000 H. 1000 - □ 16	ART. 1CT16-1200 H. 1200 - □ 16	ART. 1CT16-1500 H. 1500 - □ 16

LISSE Ø 14 - Ø 16 - Ø 18 - Ø 20



LISSE	LISSE	LISSE	LISSE
ART. P99RL-14 H. 200 - Ø 14	ART. 99RL14-1000 H. 1000 - Ø 14	ART. 99RL14-1200 H. 1200 - Ø 14	ART. 99RL14-1500 H. 1500 - Ø 14
ART. P99RL16 H. 200 - Ø 16	ART. 99RL16-1000 H. 1000 - Ø 16	ART. 99RL16-1200 H. 1200 - Ø 16	ART. 99RL16-1500 H. 1500 - Ø 16
ART. P99RL18 H. 200 - Ø 18	ART. 99RL18-1000 H. 1000 - Ø 18	ART. 99RL18-1200 H. 1200 - Ø 18	ART. 99RL18-1500 H. 1500 - Ø 18
ART. P99RL20 H. 200 - Ø 20	ART. 99RL20-1000 H. 1000 - Ø 20	ART. 99RL20-1200 H. 1200 - Ø 20	ART. 99RL20-1500 H. 1500 - Ø 20

LISSE Ø 14 - Ø 16



LISSE	LISSE	LISSE	LISSE
ART. P92RL-14 H. 200 - Ø 14	ART. 92RL-14-1000 H. 1000 - Ø 14	ART. 92RL-14-1200 H. 1200 - Ø 14	ART. 92RL-14-1500 H. 1500 - Ø 14
ART. P92RL-16 H. 200 - Ø 16	ART. 92RL-16-1000 H. 1000 - Ø 16	ART. 92RL-16-1200 H. 1200 - Ø 16	ART. 92RL-16-1500 H. 1500 - Ø 16

Flèche à plat

LISSE □ 14 - □ 16 - □ 18 - □ 20



LISSE	LISSE	LISSE	LISSE
ART. P99CL-14 H. 200 - □ 14	ART. 99CL-14-1000 H. 1000 - □ 14	ART. 99CL-14-1200 H. 1200 - □ 14	ART. 99CL-14-1500 H. 1500 - □ 14
ART. P99CL16 H. 200 - □ 16	ART. 99CL16-1000 H. 1000 - □ 16	ART. 99CL16-1200 H. 1200 - □ 16	ART. 99CL16-1500 H. 1500 - □ 16
ART. P99CL18 H. 200 - □ 18	ART. 99CL18-1000 H. 1000 - □ 18	ART. 99CL18-1200 H. 1200 - □ 18	ART. 99CL18-1500 H. 1500 - □ 18
ART. P99CL20 H. 200 - □ 20	ART. 99CL20-1000 H. 1000 - □ 20	ART. 99CL20-1200 H. 1200 - □ 20	ART. 99CL20-1500 H. 1500 - □ 20

Flèche à plat

MARTELÉ □ 14 - □ 16



LISSE	LISSE	LISSE	LISSE
ART. P92CL-14 H. 200 - □ 14	ART. 92CL-14-1000 H. 1000 - □ 14	ART. 92CL-14-1200 H. 1200 - □ 14	ART. 92CL-14-1500 H. 1500 - □ 14
ART. P92CL-16 H. 200 - □ 16	ART. 92CL-16-1000 H. 1000 - □ 16	ART. 92CL-16-1200 H. 1200 - □ 16	ART. 92CL-16-1500 H. 1500 - □ 16

TÔLE FESTONNÉE ACIER ET ELECTROZINGUÉE

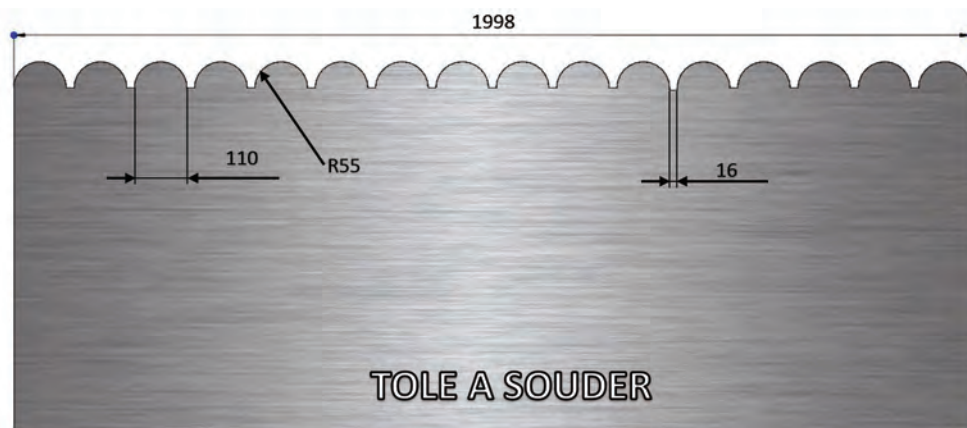

ACIER BRUT
ART. A790x1998 H. 790 - ep. 1,5 mm
ART. A990x1998 H. 990 - ep. 1,5 mm
ART. A1240x1998 H. 1240 - ep. 1,5 mm
ART. A1490x1998 H. 1490 - ep. 1,5 mm

ACIER ELECTROZINGUÉ
ART. Z790x1998 H. 790 - ep. 1,5 mm
ART. Z990x1998 H. 990 - ep. 1,5 mm
ART. Z1240x1998 H. 1240 - ep. 1,5 mm
ART. Z1490x1998 H. 1490 - ep. 1,5 mm

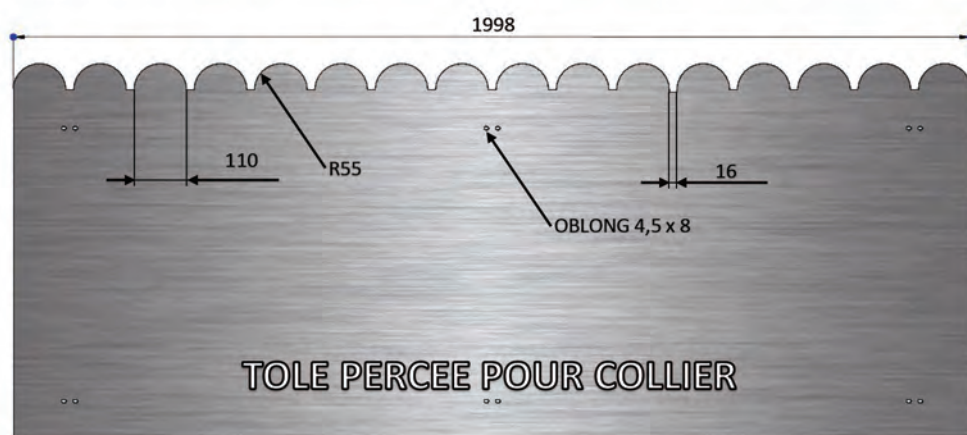

ACIER BRUT
ART. AP790x1998 H. 790 - ep. 1,5 mm
ART. AP990x1998 H. 990 - ep. 1,5 mm
ART. AP1240x1998 H. 1240 - ep. 1,5 mm
ART. AP1490x1998 H. 1490 - ep. 1,5 mm

ACIER ELECTROZINGUÉ
ART. ZP790x1998 H. 790 - ep. 1,5 mm
ART. ZP990x1998 H. 990 - ep. 1,5 mm
ART. ZP1240x1998 H. 1240 - ep. 1,5 mm
ART. ZP1490x1998 H. 1490 - ep. 1,5 mm

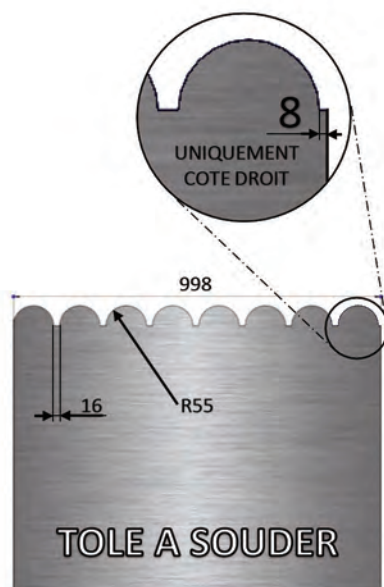

ACIER BRUT
ART. A790x998 H. 790 - ep. 1,5 mm
ART. A990x998 H. 990 - ep. 1,5 mm
ART. A1240x998 H. 1240 - ep. 1,5 mm
ART. A1490x998 H. 1490 - ep. 1,5 mm
ACIER ELECTROZINGUÉ
ART. Z790x998 H. 790 - ep. 1,5 mm
ART. Z990x998 H. 990 - ep. 1,5 mm
ART. Z1240x998 H. 1240 - ep. 1,5 mm
ART. Z1490x998 H. 1490 - ep. 1,5 mm

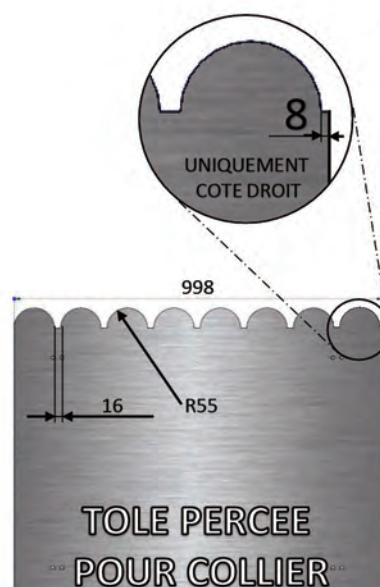

ACIER BRUT
ART. AP790x998 H. 790 - ep. 1,5 mm
ART. AP990x998 H. 990 - ep. 1,5 mm
ART. AP1240x998 H. 1240 - ep. 1,5 mm
ART. AP1490x998 H. 1490 - ep. 1,5 mm
ACIER ELECTROZINGUÉ
ART. ZP790x998 H. 790 - ep. 1,5 mm
ART. ZP990x998 H. 990 - ep. 1,5 mm
ART. ZP1240x998 H. 1240 - ep. 1,5 mm
ART. ZP1490x998 H. 1490 - ep. 1,5 mm

COLLIER GALVANISÉ



ACIER GALVANISÉ
ART. CF14 Serrage Ø 14 mm
ART. CF16 Serrage Ø 16 mm

ACIER GALVANISÉ
ART. CF18 Serrage Ø 18 mm
ART. CF20 Serrage Ø 20 mm



BARREAUX AVEC FLÈCHES ESTAMPÉES SOUDÉES

H 1000-1200- 1500



LISSE
ART. BP32-1000 H 1000 - Ø16
ART. BP32-1200 H 1200 - Ø16
ART. BP32-1500 H 1500 - Ø16

LISSE
ART. BP17B-1000 H 1000 - Ø16
ART. BP17B-1200 H 1200 - Ø16
ART. BP17B-1500 H 1500 - Ø16

LISSE
ART. BP41-1000 H 1000 - Ø16
ART. BP41-1200 H 1200 - Ø16
ART. BP41-1500 H 1500 - Ø16

LISSE
ART. BP9-1000 H 1000 - Ø16
ART. BP9-1200 H 1200 - Ø16
ART. BP9-1500 H 1500 - Ø16

LISSE
ART. BFL21-1000 H 1000 - Ø16
ART. BFL21-1200 H 1200 - Ø16
ART. BFL21-1500 H 1500 - Ø16

LISSE
ART. BP31-1000 H 1000 - Ø16
ART. BP31-1200 H 1200 - Ø16
ART. BP31-1500 H 1500 - Ø16

*

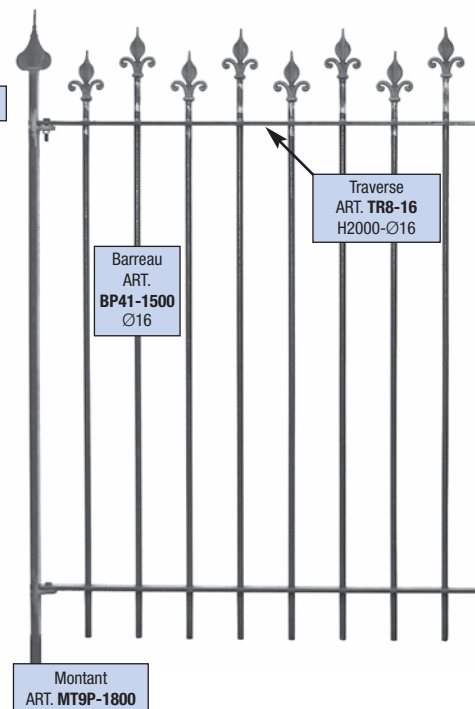
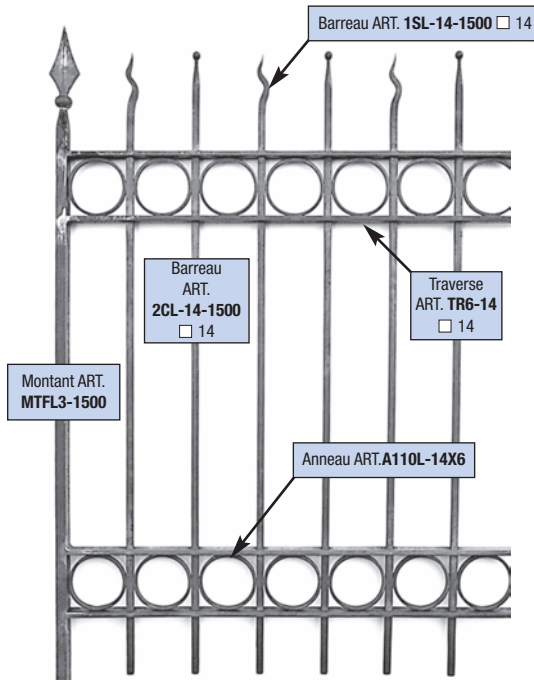
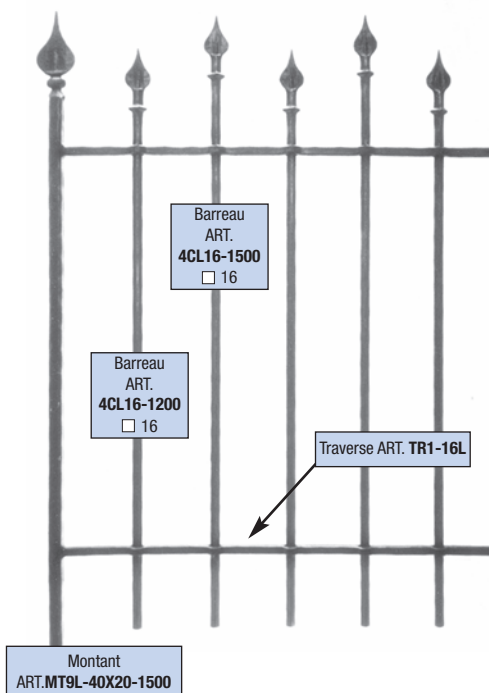

*Modèle déposé



ART. FL1
H. 240 - Ø 25



ART. FL2
H. 210 - Ø 20



ART. FL3
H. 180 - Ø 16



ART. FL21
H. 180 - Ø 29



ART. FL22
H. 205 - Ø 35



ART. FL4
H. 235 x L 95



ART. FL5
H. 190 x L 70



ART. FL6
H. 95 x L 30
Base Ø 30



ART. FL7
H. 120 x L 35
Base Ø 14-16



ART. FL8
H. 220 x L 45
Base Ø 20



ART. FL9
H. 110 x L 30
Base Ø 16 conique



ART. FL10
H. 110 x L 30
Base Ø 16 conique



ART. FL11
H. 120 x L 40
Base □ 20



ART. FL12
H. 110 x L 40
Base □ 25



ART. FL15
H. 80 x L 50
Base Ø 40



ART. BD20
H. 160 x L 100
Base Ø 70



ART. FL16
H. 105 x L 70
Base Ø 50



ART. FL17
H. 80 x L 50
Base Ø 40



ART. FL18
H. 60 x L 40
Base Ø 30



LISSE	LISSE	LISSE	LISSE	LISSE	LISSE	LISSE	LISSE	LISSE
ART. MT1L25-1500 H. 1500 - □ 25	ART. MT1L25-2000 H. 2000 - □ 25	ART. MT1L40X15-1500 H.1500 - □ 40x15	ART. MT2LB25-1500 H. 1500 - □ 25	ART. MT2LB40X20 H.2000 - □ 40x20	ART. MT9L40X20-1500 H.1500 - □ 40x20	ART. MTFL3-1500 H 1500 - □ 40x20	ART. MT9P-1800 H 1800 - □ 40x20	ART. MT9P40-1800 H 1800 - □ 40
ART. MT1L30-1500 H. 1500 - □ 30	ART. MT1L30-2000 H. 2000 - □ 30	ART. MT1L40X15-2000 H.2000 - □ 40x15	ART. MT2LB25-2000 H. 2000 - □ 25		ART. MT9L40X20-2000 H.2000 - □ 40x20	ART. MTFL3-2000 H 2000 - □ 40x20		
ART. MT1L35-1500 H. 1500 - □ 35	ART. MT1L35-2000 H. 2000 - □ 35	ART. MT1L40X20-1500 H.1500 - □ 40x20	ART. MT2LB30-2000 H. 2000 - □ 30					
ART. MT1L40-1500 H. 1500 - □ 40	ART. MT1L40-2000 H. 2000 - □ 40	ART. MT1L40X20-2000 H.2000 - □ 40x20						



LISSE
ART. P1CL25 H. 200 - □ 25
ART. P1CL30 H. 200 - □ 30
ART. P1CL35 H. 200 - □ 35
ART. P1CL40 H. 200 - □ 40

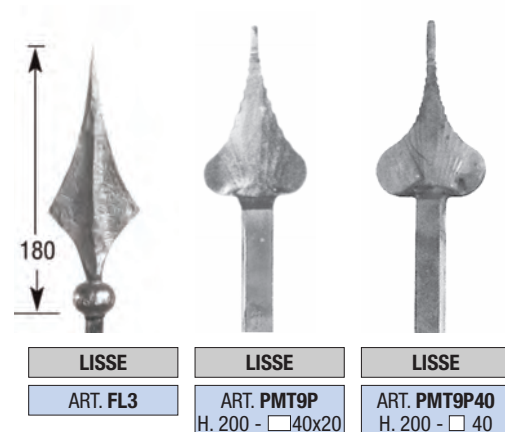

LISSE	LISSE	LISSE
ART. FL3	ART. PMT9P H. 200 - □ 40x20	ART. PMT9P40 H. 200 - □ 40



MARTELÉ	MARTELÉ	MARTELÉ	MARTELÉ	MARTELÉ	MARTELÉ	MARTELÉ
ART. MT1M25-1500 H. 1500 - □ 25	ART. MT1M25-2000 H. 2000 - □ 25	ART. MT1M40X20-1500 H.1500 - □ 40x20	ART. MT2MB25-1500 H. 1500 - □ 25	ART. MT2MB40X20 H.2000 - □ 40x20	ART. MTV30-1500 H. 1500 - □ 30	ART. MTVM35-2000 H. 2000 - □ 35
ART. MT1M30-1500 H. 1500 - □ 30	ART. MT1M30-2000 H. 2000 - □ 30	ART. MT1M40X20-2000 H.2000 - □ 40x20	ART. MT2MB25-2000 H. 2000 - □ 25		ART. MTV30-2000 H. 2000 - □ 30	
ART. MT1M35-1500 H. 1500 - □ 35	ART. MT1M35-2000 H. 2000 - □ 35		ART. MT2MB30-2000 H. 2000 - □ 30			
ART. MT1M40-1500 H. 1500 - □ 40	ART. MT1M40-2000 H. 2000 - □ 40					



MARTELÉ
ART. P1CM25 H. 200 - □ 25
ART. P1CM30 H. 200 - □ 30
ART. P1CM35 H. 200 - □ 35
ART. P1CM40 H. 200 - □ 40



LISSE
ART. PMTV25 H. 200 - □ 25
ART. PMTV30 H. 200 - □ 30
ART. PMTV35 H. 200 - □ 35
ART. PMTV40 H. 200 - □ 40
ART. PMTV30X20 H. 200 - □ 30x20
ART. PMTV35X20 H. 200 - □ 35x20



VOLUTES FER PLAT

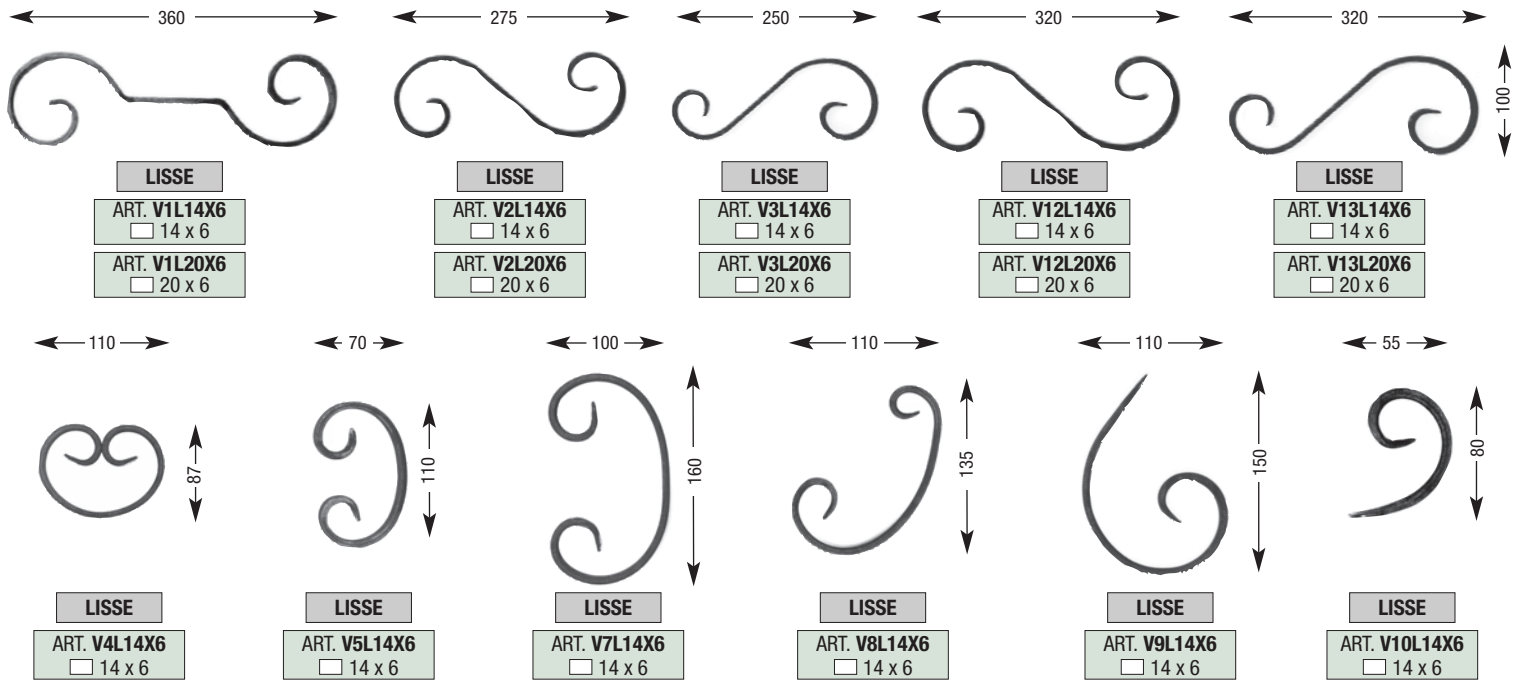

ANNEAUX FER PLAT

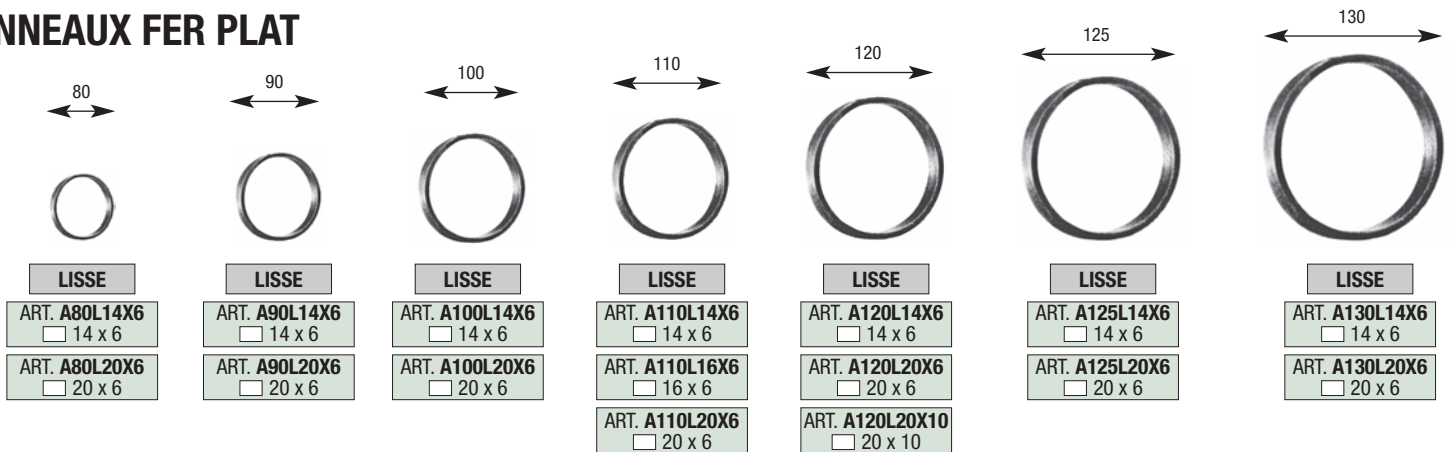

ANNEAUX FER ROND

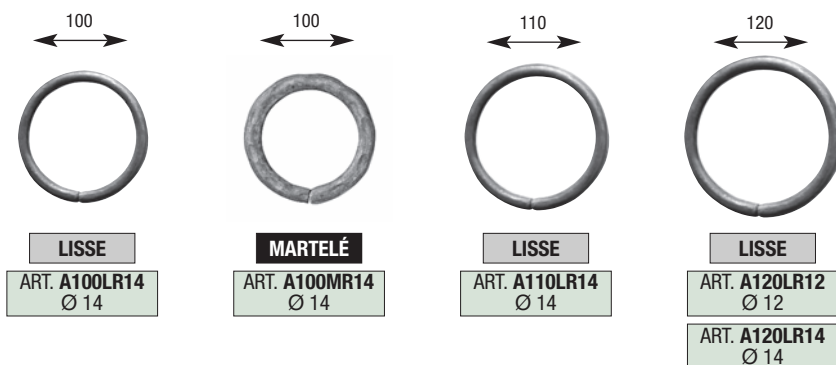

ANNEAUX FER CARRÉ

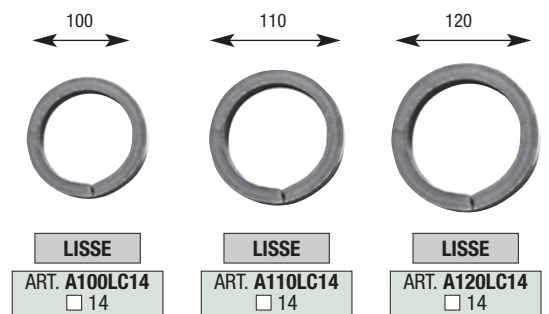

OVALES

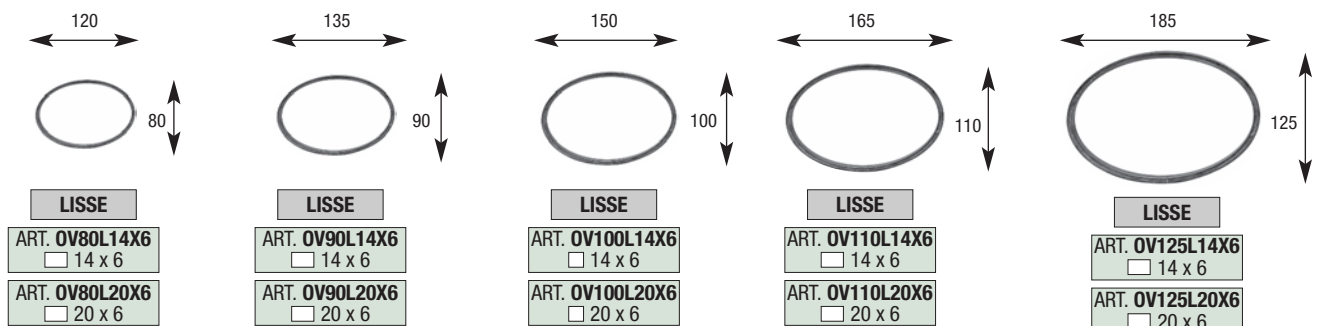

VOLUTES A NOYAUX - LISSE

SÉRIE 100

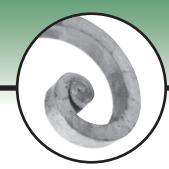

 360 LISSE ART. V101L14X6 14 x 6	 295 LISSE ART. V110L14X6 14 x 6	 320 LISSE ART. V102L14X6 14 x 6	 320 LISSE ART. V103L14X6 14 x 6
 65 110 LISSE ART. V105L14X6 14 x 6	 100 155 LISSE ART. V106L14X6 14 x 6	 110 140 LISSE ART. V107L14X6 14 x 6	 110 140 LISSE ART. V108L14X6 14 x 6
 235 170 LISSE ART. V109L14X6 14 x 6			
 380 100 LISSE ART. V104L14X6 14 x 6	 240 100 LISSE ART. V114L14X6 14 x 6	 210 100 LISSE ART. V115L14X6 14 x 6	 exemples de frise
 300 100 LISSE ART. V116L14X6 14 x 6	 540 100 LISSE ART. V117L14X6 14 x 6	 480 100 LISSE ART. V118L14X6 14 x 6	

SÉRIE 200

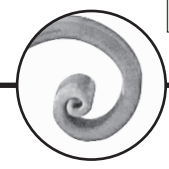

 360 LISSE ART. V201L14X6 14 x 6	 295 LISSE ART. V210L14X6 14 x 6	 320 LISSE ART. V202L14X6 14 x 6	 320 LISSE ART. V203L14X6 14 x 6
 75 260 LISSE ART. V201L20X6 20 x 6	 65 110 LISSE ART. V202L20X6 20 x 6	 100 155 LISSE ART. V206L14X6 14 x 6	 110 140 LISSE ART. V207L14X6 14 x 6
 110 140 LISSE ART. V208L14X6 14 x 6	 235 170 LISSE ART. V209L14X6 14 x 6		
 380 100 LISSE ART. V204L14X6 14 x 6	 240 100 MARTELÉ ART. V204M14X6 14 x 6	 210 100 LISSE ART. V214L14X6 14 x 6	 360 120 LISSE ART. V215L14X6 14 x 6
		 LISSE ART. V202L20X10 20 x 10	

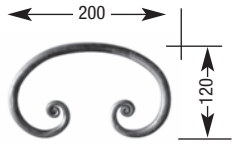

LISSE
ART. VR3-12
Ø 12

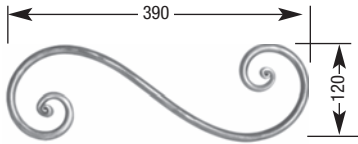

LISSE
ART. VR1-12
Ø 12

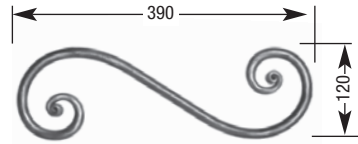

LISSE
ART. VR6-14
Ø 14

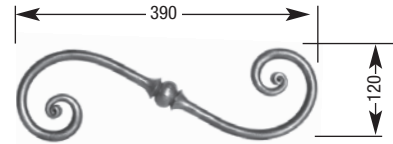

LISSE
ART. VR9-14
Ø 14

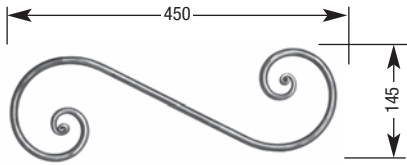

LISSE
ART. VR2-12
Ø 12

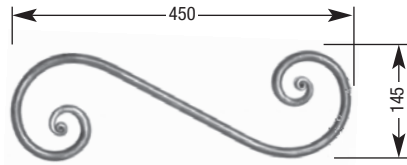

LISSE
ART. VR7-14
Ø 14

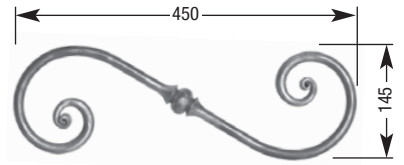

LISSE
ART. VR10-14
Ø 14

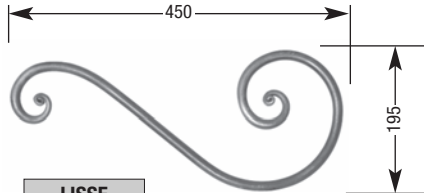

LISSE
ART. VR5-14
Ø 14



LISSE
ART. VR8-14
Ø 14

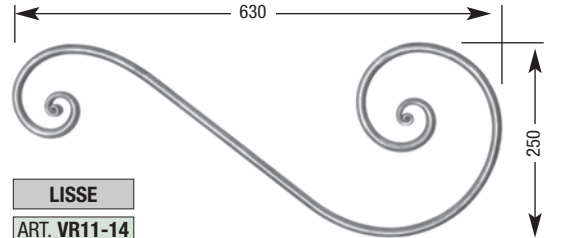

LISSE
ART. VR11-14
Ø 14

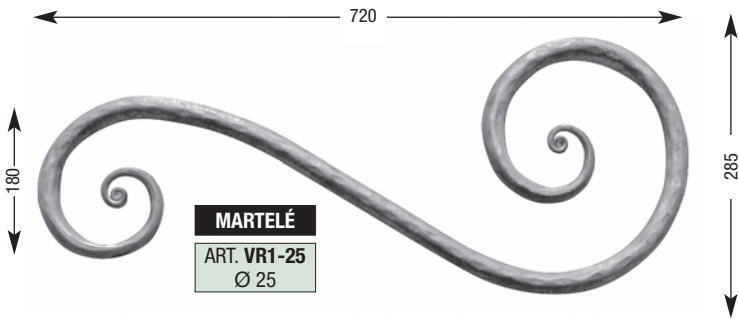

MARTELÉ
ART. VR1-25
Ø 25

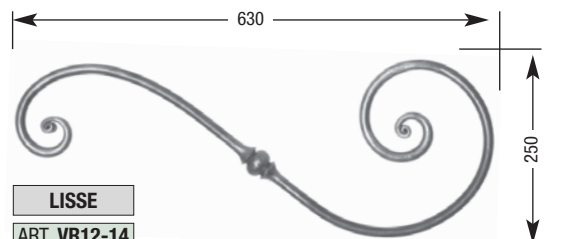

LISSE
ART. VR12-14
Ø 14

FRONTON DE PORTAIL

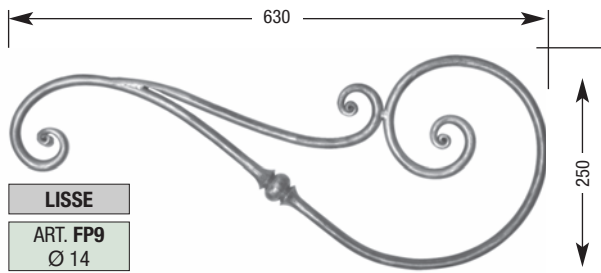

LISSE
ART. FP9
Ø 14

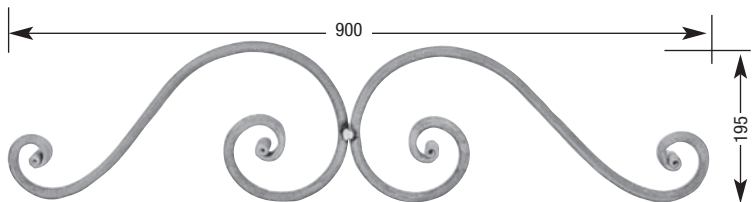

LISSE
ART. FP10
Ø 14

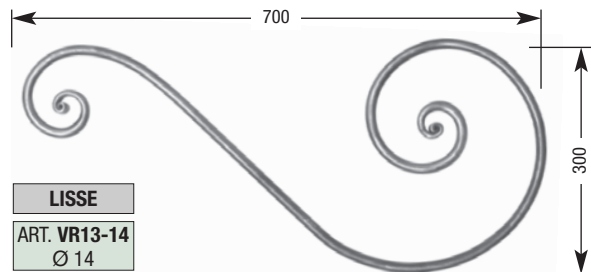

LISSE
ART. VR13-14
Ø 14

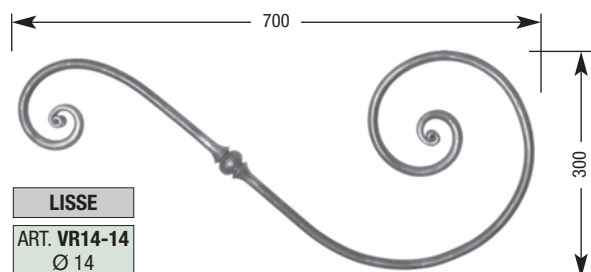

LISSE
ART. VR14-14
Ø 14



VOLUTES À NOYAUX FORGÉS □ FER CARRÉ

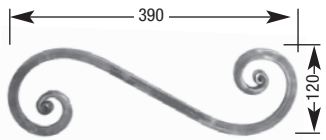

LISSE
ART. VC1-14
□ 14

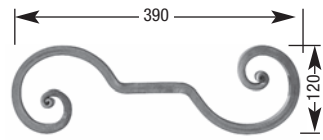

LISSE
ART. VC11-14
□ 14



LISSE
ART. VC7-14
□ 14

MARTELÉ
ART. VC8-14
□ 14

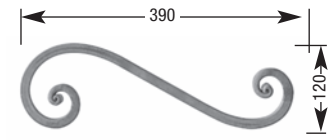

LISSE
ART. VC12-14
□ 14

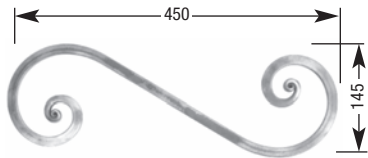

LISSE
ART. VC2-14
□ 14

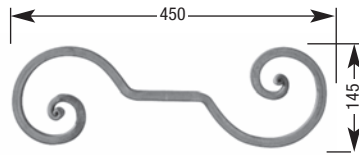

LISSE
ART. VC13-14
□ 14

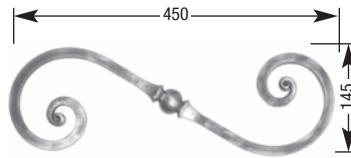

LISSE
ART. VC9-14
□ 14

MARTELÉ
ART. VC10-14
□ 14

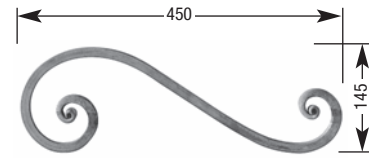

LISSE
ART. VC14-14
□ 14

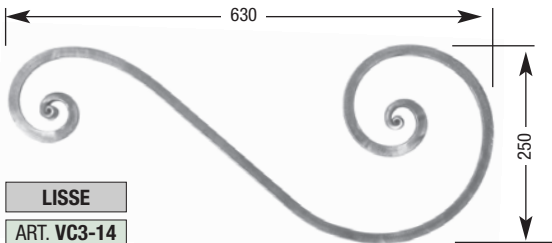

LISSE
ART. VC3-14
□ 14



LISSE
ART. VC4-14
□ 14

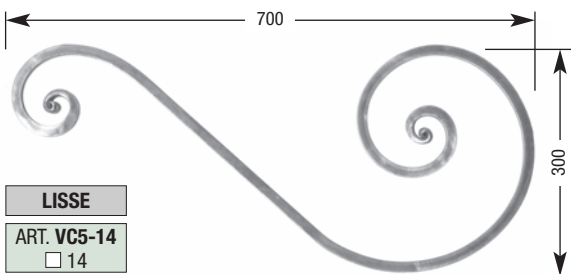

LISSE
ART. VC5-14
□ 14

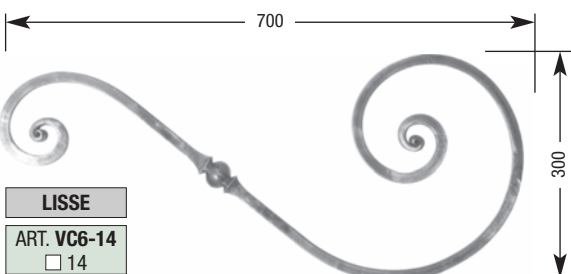

LISSE
ART. VC6-14
□ 14

VOLUTES À NOYAUX FORGÉS □ FER PLAT

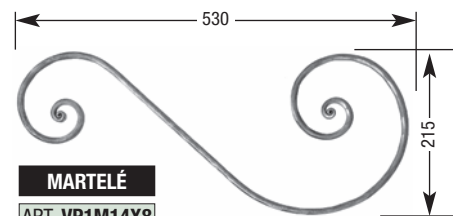

MARTELÉ
ART. VP1M14X8
□ 14x8

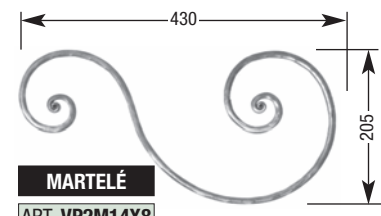

MARTELÉ
ART. VP2M14X8
□ 14x8

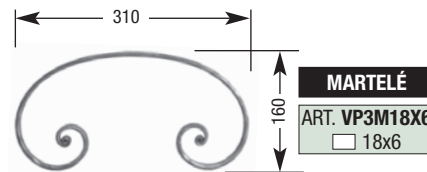

MARTELÉ
ART. VP3M18X6
□ 18x6

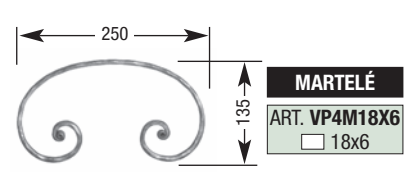

MARTELÉ
ART. VP4M18X6
□ 18x6



MARTELÉ
ART. VB107-14
□ 14

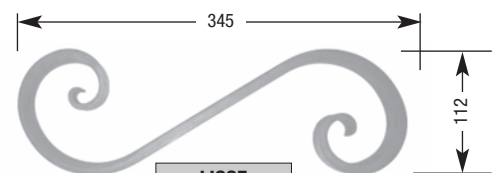

LISSE
ART. V402L
□ 20x10

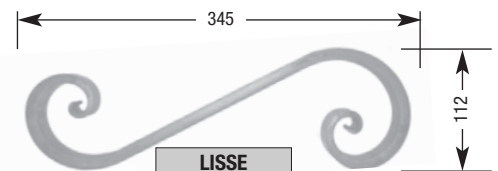

LISSE
ART. V403L
□ 20x10

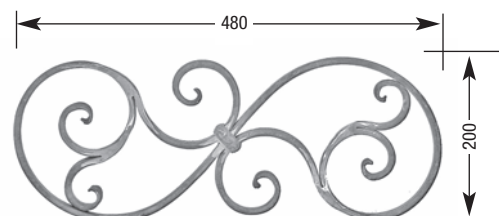

MARTELÉ
ART. VB106-16X8
□ 16x8

VOLUTES A FORMER - LISSES

<p>LISSE ART. VF100-14 H. 910 - □ 14</p>	<p>LISSE ART. VF101-14X6 H.910 - □ 14x6</p>	<p>LISSE ART. VF211-14 H. 910 - □ 14</p>	<p>LISSE ART. VF210-14 H. 910 - □ 14</p>	<p>LISSE ART. VF201-14X8 H. 910 - □ 14x8</p>	<p>LISSE ART. VF200-14X8 H. 910 - □ 14x8</p>	<p>LISSE ART. VF301-R14 H. 910 - Ø 14</p>	<p>LISSE ART. VF300-R14 H. 910 - Ø 14</p>
<p>LISSE ART. VF211-16 H.910 - □ 16</p>	<p>LISSE ART. VF210-16 H.910 - □ 16</p>	<p>LISSE ART. VF201-20X10 H.910 - □ 20x10</p>	<p>LISSE ART. VF200-20X10 H.910 - □ 20x10</p>	<p>LISSE ART. VF301-R16 H.910 - Ø 16</p>	<p>LISSE ART. VF300-R16 H.910 - Ø 16</p>	<p>LISSE ART. VF301-R20 H.910 - Ø 20</p>	<p>LISSE ART. VF300-R20 H.910 - Ø 20</p>

VOLUTES DÉCORATIVES

<p>MARTELÉ ART. VD10 □ 14 x 6</p>	<p>MARTELÉ ART. VD11 Ø 14</p>
<p>MARTELÉ ART. VD1 □ 14 x 6</p>	<p>MARTELÉ ART. VD12 Ø 12</p>
<p>LISSE ART. VD3 □ 14 x 6</p>	<p>LISSE ART. VD5 □ max. 20</p>
<p>MARTELÉ ART. VD2 □ 14 x 6</p>	<p>LISSE ART. VD7 □ max. 22</p>
<p>LISSE ART. VD4 □ 14 x 6</p>	<p>LISSE ART. VD6 □ max. 22</p>

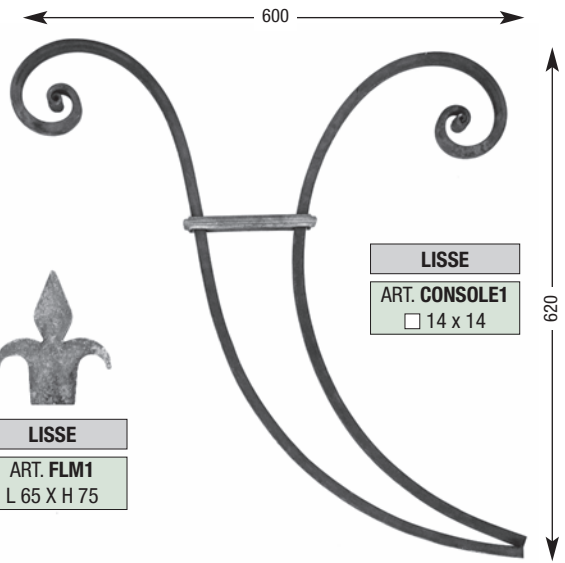
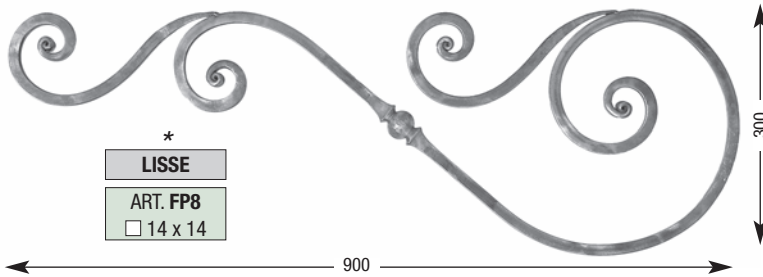
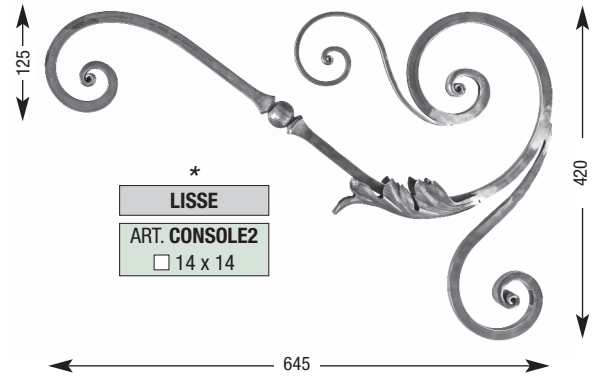
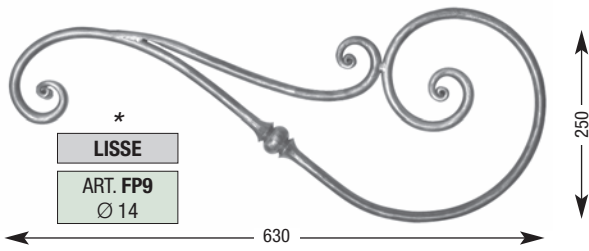

TÔLES DÉCORATIVES épaisseur 2 mm

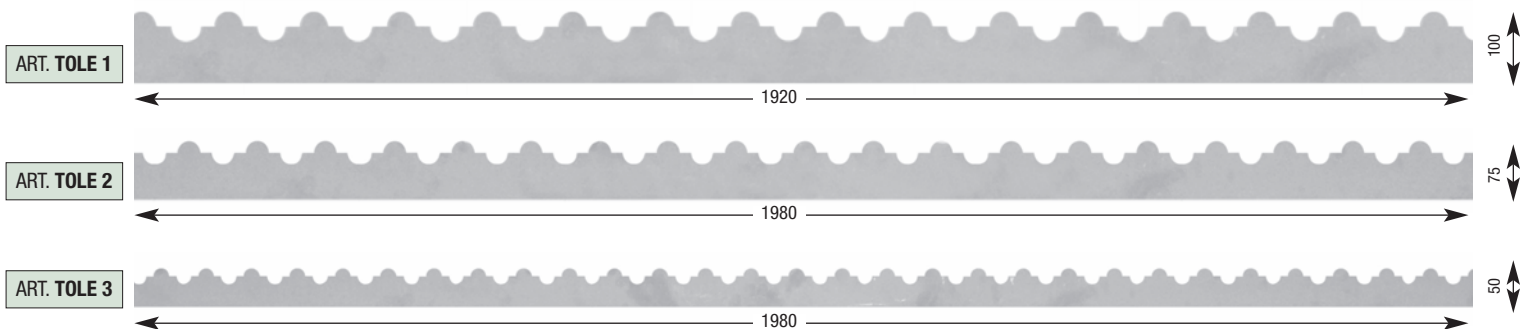

CLÉS DE TIRANT

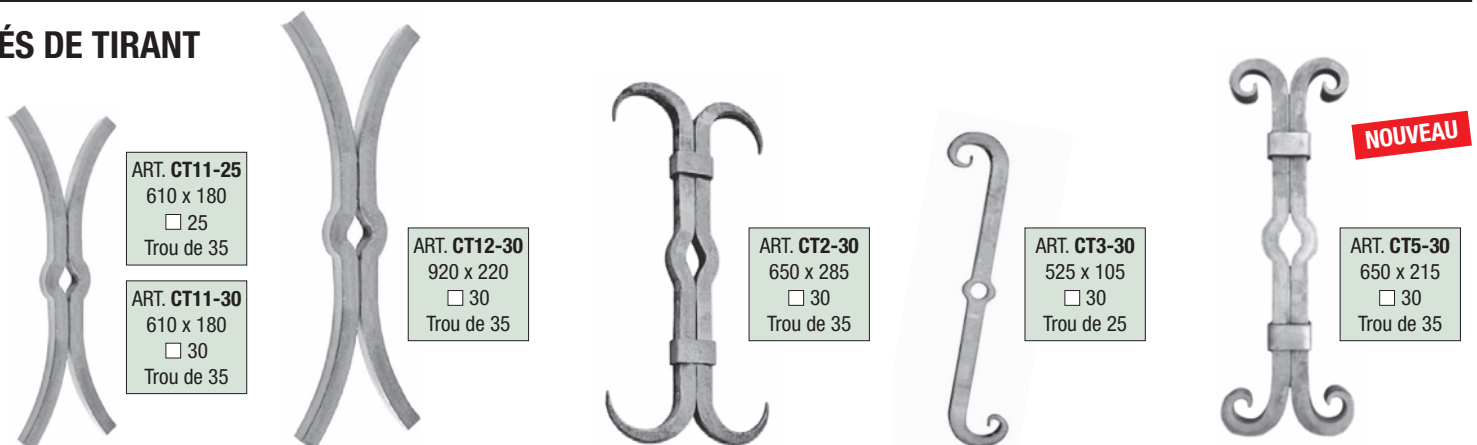

CINTRES EN CARRÉS

MARTELÉ	ART. TRAVC25M-3	<input type="checkbox"/> 25x25	L. 3000	fer carré	A 400
MARTELÉ	ART. TRAVC25M-4	<input type="checkbox"/> 25x25	L. 4000	fer carré	A 500
MARTELÉ	ART. TRAVC30M-4	<input type="checkbox"/> 30x30	L. 4000	fer carré	A 500

CINTRES À T LISSES

LISSE	ART. TRAVT40-3	T40	L. 3000	A 400	
LISSE	ART. TRAVT40-4	T40	L. 4000	A 500	

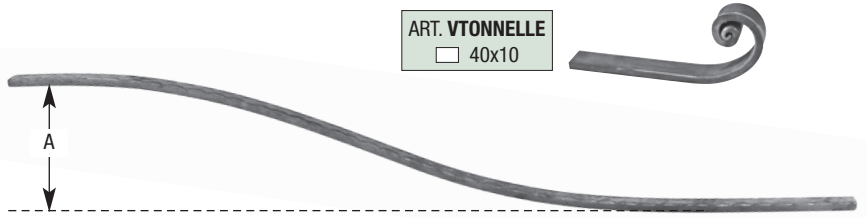

CINTRES EN CARRÉS MARTELÉS

MARTELÉ	ART. TRAVA25M-3	<input type="checkbox"/> 25x25	L. 3000	fer carré	A 370
MARTELÉ	ART. TRAVA25M-4	<input type="checkbox"/> 25x25	L. 4000	fer carré	A 370

CINTRES À T LISSES

LISSE	ART. TRAVAT40-3	T40	L. 3000	A 370	
LISSE	ART. TRAVAT40-4	T40	L. 4000	A 370	

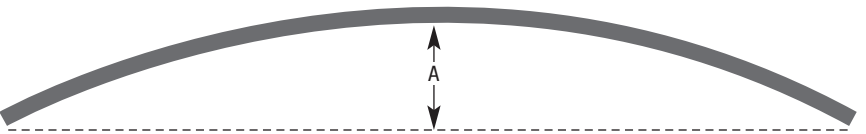

ÉLÉMENTS POUR BANDEAU

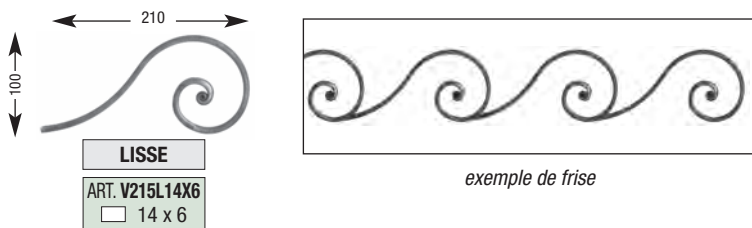
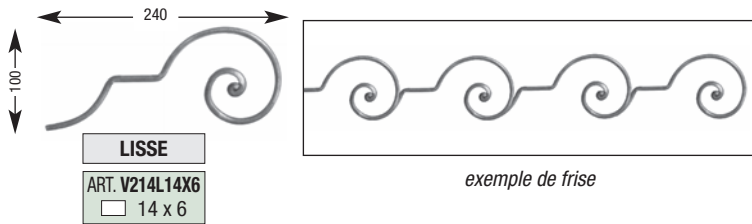
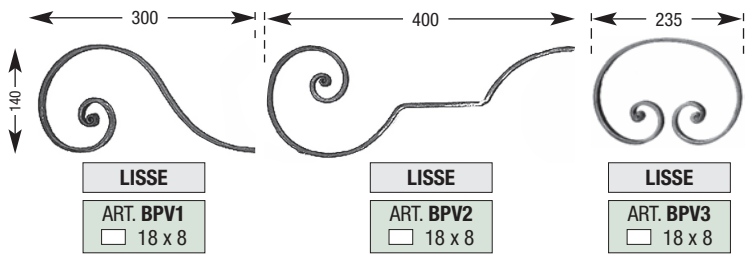

PERCÉ TARAUDÉ M12



MONTANTS DE TONNELLE

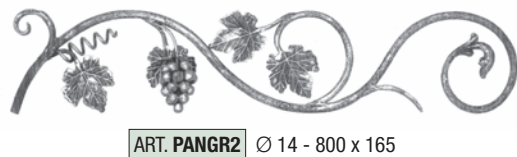
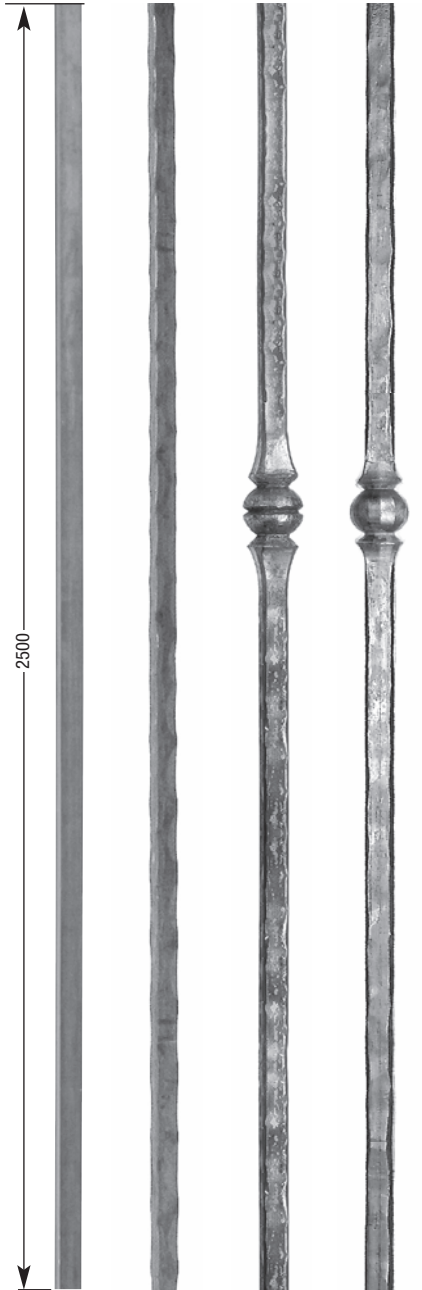

LISSE	MARTELÉ	MARTELÉ	MARTELÉ
ART. CL25T H.2500-□25	ART. CM25T H.2500-□25	ART. MT15CT25 H.2500-□25	
ART. CL30T H.2500-□30	ART. CM30T H.2500-□30	ART. MT15CT30 H.2500-□30	ART. MT21T30 H.2500-□30

* *Modèle déposé*

BOULE TERMINAISON

ART. B22A
base Ø 90 mm
boule Ø 110 mm
H. 140 mm

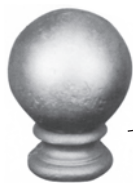

TUBE CINTRÉ 30 x 20 à recouper

ART. SC8R500 rayon 500
ART. SC8R550 rayon 550
ART. SC8R600 rayon 600
ART. SC8R650 rayon 650

EXEMPLE
DE MONTAGE

TUBE DROIT

ART. SC7-750
Tube 30 x 20 - L. 750 à recouper

TUBE CENTRAL



ART. TUBE CENTRAL
Ø ext. 60 mm
H. 3000 mm

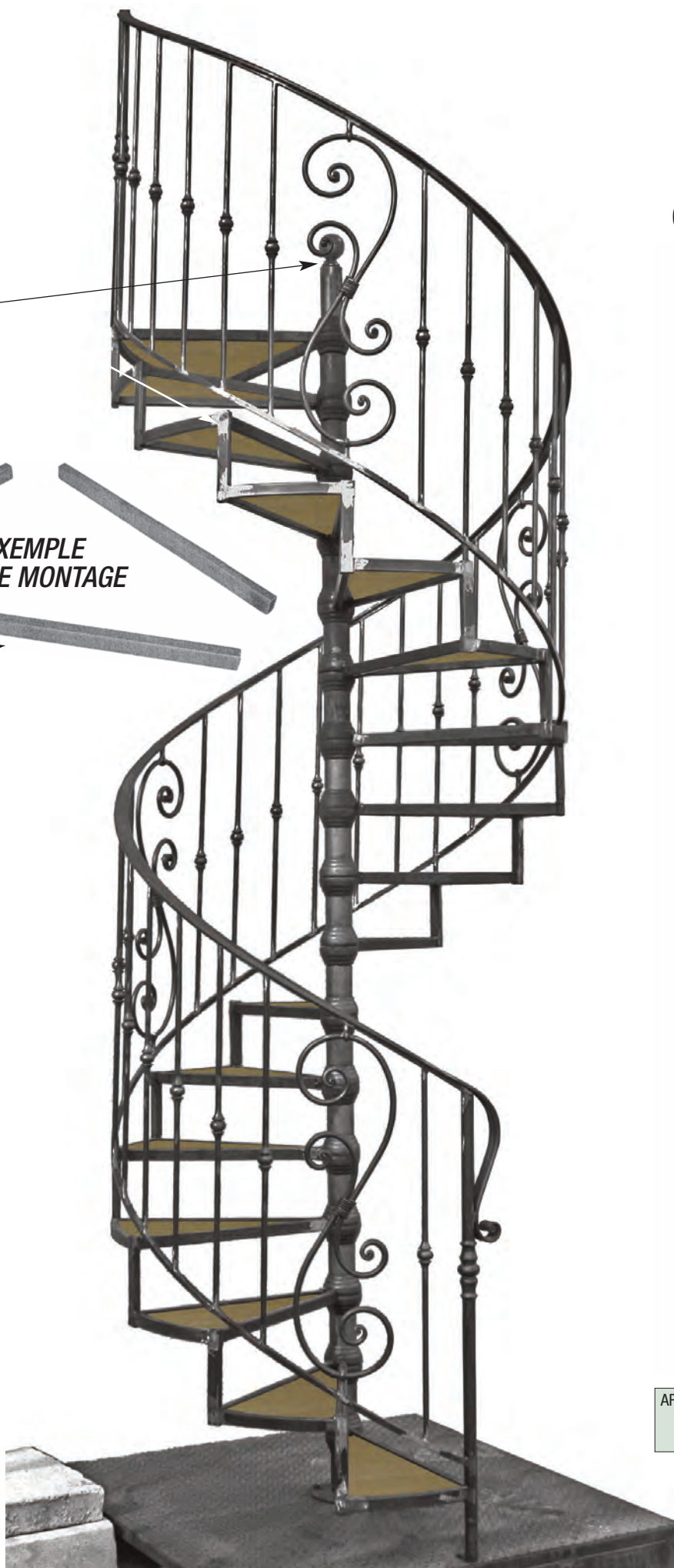

LAITON

NOUVEAU



ART. RL-02
Ø 90



ART. RLME3092
Ø 165



ART. RLME3094
Ø 155



ART. PAFME3089
370 x 240

ALUMINIUM



ART. F61-163
Ø 100



ART. F61-162
400 x 200



ART. PAL01
380 x 210

FORTE

Fonte non soudable - Côtes pouvant varier



ART. ANGLES
140 x 140



ART. PAF01
380 x 210

ART. PAF01G
450 x 254



ART. ANGLES
140 x 140



ART. PAF02
560 x 280

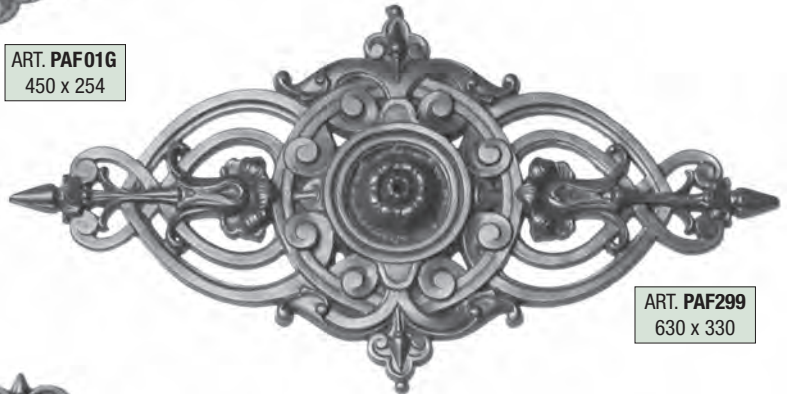

ART. PAF299
630 x 330



ART. PAFR088
325 x 165



ART. PAF5
400 x 170



ART. PAFR089
335 x 130



ART. ROF01
Ø 90



ART. ROF02
Ø 100



ART. F61-160
370 x 240

ÉLÉMENTS POUR PORTAILS

COURONNEMENT DE PORTAIL

MARTELÉ

ART. CP1
H 400 - □ 25x25

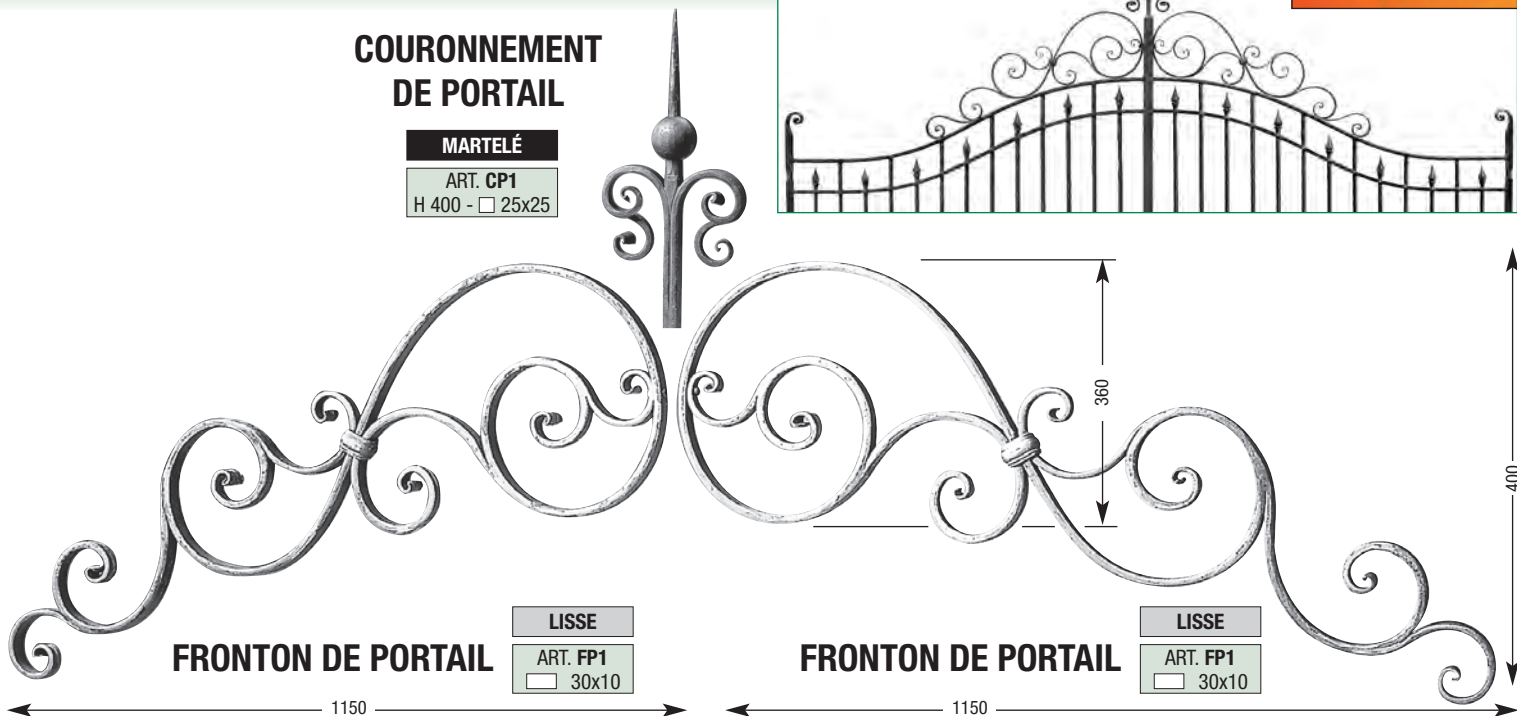

FRONTON DE PORTAIL

*

LISSE

ART. FP8
□ 14 X 14

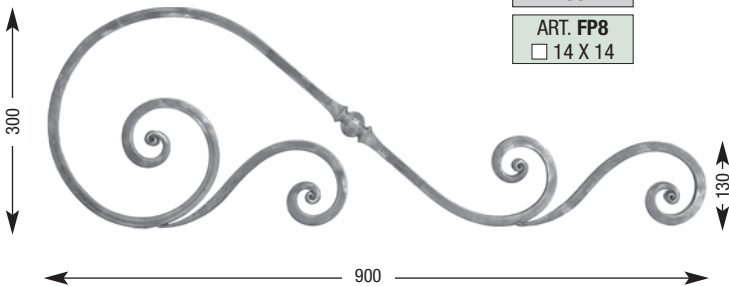

FRONTON DE PORTAIL

*

LISSE

ART. FP9
Ø 14

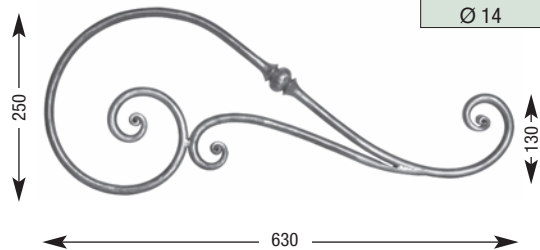

FRONTON DE PORTAIL

LISSE

ART. FP2
□ 20 X 8

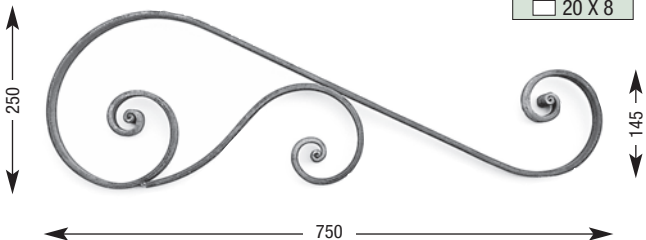

FRONTON DE PORTAIL

LISSE

ART. FP10
Ø 14

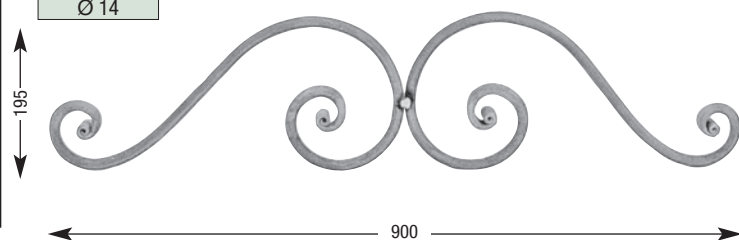

BANDEAU DE PORTAIL

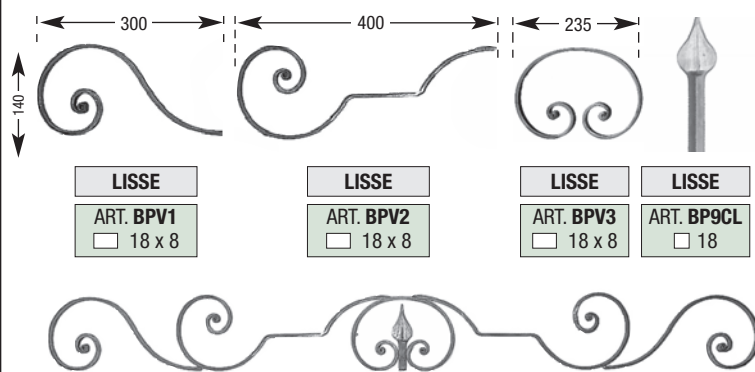

MONTANTS DE PORTAIL

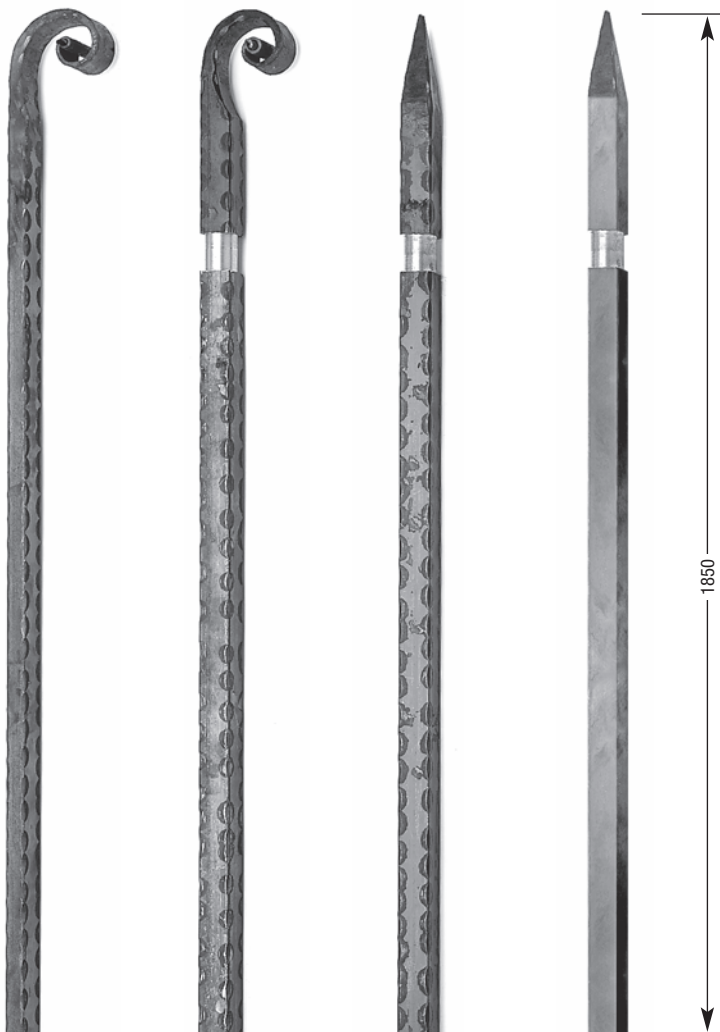

MARTELÉ	MARTELÉ	MARTELÉ	LISSE
ART. MTP2 H. 2150 - □ 35x20	ART. MTP4 H. 1850 - □ 35	ART. MTP6 H. 1850 - □ 35	ART. MTP6L-35 H. 1850 - □ 35x35
LISSE			ART. MTP6L-30 H. 1850 - □ 30x30
ART. MTP2L H. 2150 - □ 35x20			

EMBOUS DE MONTANTS

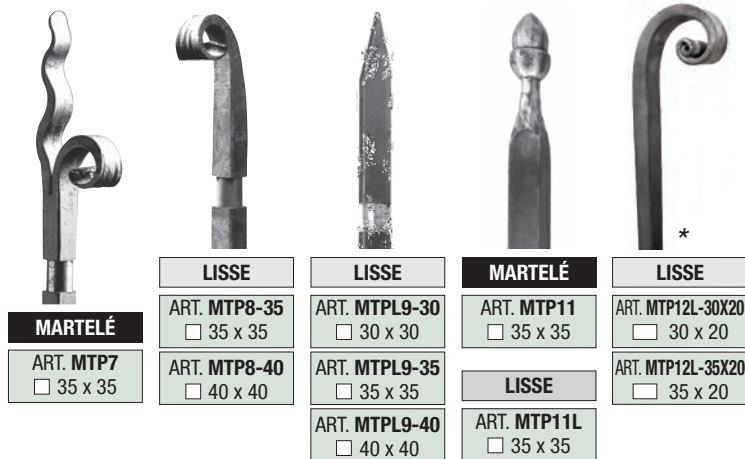

MARTELÉ	LISSE	LISSE	MARTELÉ	LISSE
ART. MTP7 □ 35 x 35	ART. MTP8-35 □ 35 x 35	ART. MTP9-30 □ 30 x 30	ART. MTP11 □ 35 x 35	ART. MTP12L-30X20 □ 30 x 20
	ART. MTP8-40 □ 40 x 40	ART. MTP9-35 □ 35 x 35	LISSE	ART. MTP12L-35X20 □ 35 x 20
		ART. MTP9-40 □ 40 x 40	ART. MTP11L □ 35 x 35	

BATTUES



LISSE	MARTELÉ
ART. BAT1 H 1800 - □ 50x6	ART. BAT2 H 2150 - □ 50x6

EMBOUS DE BATTUES

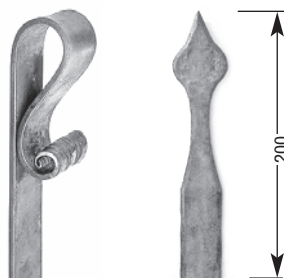

LISSE	LISSE
ART. BAT3 □ 50x6	ART. BAT4 □ 50x6

VERROU

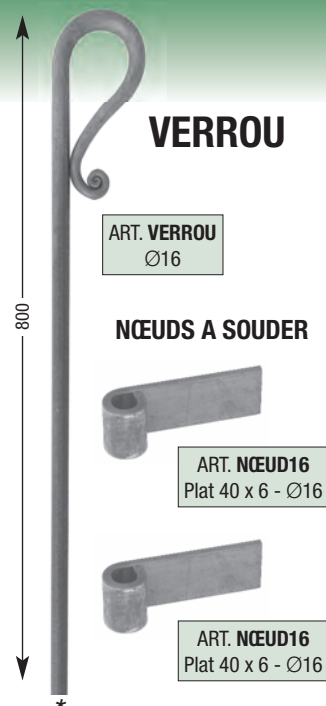

ART. VERROU
Ø16

NŒUDS A SOUDER

ART. NŒUD16
Plat 40 x 6 - Ø16

ART. NŒUD16
Plat 40 x 6 - Ø16

TALON DE PORTAIL

ART. TAL2-30	60 x 60
ART. TAL2-35	60 x 60
ART. TAL2-40	60 x 60

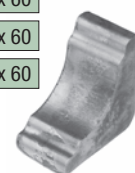

GALOCHE

ART. GAL2
□ 60 x 6



GALOCHE ESTAMPÉE

ART. GAL1
Ø 100



PLAQUE POUR SERRURE

ART. PLAQUE1G
H.275 x L.160
ép. 3mm

ART. PLAQUE1D
H.275 x L.160
ép. 3mm



BORDURES DÉFENSIVES

longueur 2 m.

ART. BORD1 épaisseur 5 mm

ART. BORD2 épaisseur 3 mm

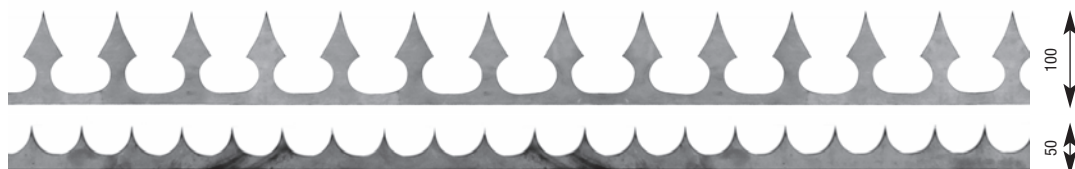

CINTRES EN FER PLAT MARTELÉS POUR PORTAIL



MARTELÉ	ART. TCM30X15	<input type="checkbox"/>	30x15	L. 2000	fer plat
MARTELÉ	ART. TCM30X20	<input type="checkbox"/>	30x20	L. 2000	fer plat
MARTELÉ	ART. TCM35X15	<input type="checkbox"/>	35x15	L. 2000	fer plat
MARTELÉ	ART. TCM35X20	<input type="checkbox"/>	35x20	L. 2000	fer plat
MARTELÉ	ART. TCM40X15	<input type="checkbox"/>	40x15	L. 2000	fer plat
MARTELÉ	ART. TCM40X20	<input type="checkbox"/>	40x20	L. 2000	fer plat

CINTRES EN FER PLAT LISSES POUR PORTAIL



LISSE	ART. TCL30X15	<input type="checkbox"/>	30x15	L. 2000	fer plat
LISSE	ART. TCL30X20	<input type="checkbox"/>	30x20	L. 2000	fer plat
LISSE	ART. TCL35X15	<input type="checkbox"/>	35x15	L. 2000	fer plat
LISSE	ART. TCL35X20	<input type="checkbox"/>	35x20	L. 2000	fer plat
LISSE	ART. TCL40X15	<input type="checkbox"/>	40x15	L. 2000	fer plat
LISSE	ART. TCL40X20	<input type="checkbox"/>	40x20	L. 2000	fer plat

CINTRES EN FER PLAT MARTELÉS POUR PORTILLON



MARTELÉ	ART. TCMC25X15	<input type="checkbox"/>	25x15	L. 1000	fer plat
MARTELÉ	ART. TCMC30X15	<input type="checkbox"/>	30x15	L. 1000	fer plat
MARTELÉ	ART. TCMC30X20	<input type="checkbox"/>	30x20	L. 1000	fer plat
MARTELÉ	ART. TCMC35X15	<input type="checkbox"/>	35x15	L. 1000	fer plat
MARTELÉ	ART. TCMC35X20	<input type="checkbox"/>	35x20	L. 1000	fer plat
MARTELÉ	ART. TCMC40X15	<input type="checkbox"/>	40x15	L. 1000	fer plat
MARTELÉ	ART. TCMC40X20	<input type="checkbox"/>	40x20	L. 1000	fer plat

CINTRES EN FER PLAT LISSES POUR PORTILLON



LISSE	ART. TCLC25X15	<input type="checkbox"/>	25x15	L. 1000	fer plat
LISSE	ART. TCLC30X15	<input type="checkbox"/>	30x15	L. 1000	fer plat
LISSE	ART. TCLC30X20	<input type="checkbox"/>	30x20	L. 1000	fer plat
LISSE	ART. TCLC35X15	<input type="checkbox"/>	35x15	L. 1000	fer plat
LISSE	ART. TCLC35X20	<input type="checkbox"/>	35x20	L. 1000	fer plat
LISSE	ART. TCLC40X15	<input type="checkbox"/>	40x15	L. 1000	fer plat
LISSE	ART. TCLC40X20	<input type="checkbox"/>	40x20	L. 1000	fer plat

CINTRES EN TUBE MARTELÉS POUR PORTAIL



MARTELÉ	ART. TCMT40X20	<input type="checkbox"/>	40x20	L. 2000	tube
----------------	----------------	--------------------------	-------	---------	------

CINTRES EN TUBE LISSES POUR PORTAIL



LISSE	ART. TCLT40X20	<input type="checkbox"/>	40x20	L. 2000	tube
--------------	----------------	--------------------------	-------	---------	------

CINTRES EN FER PLAT MARTELÉS POUR PORTAIL

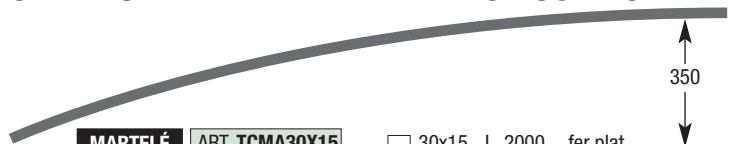

MARTELÉ	ART. TCMA30X15	<input type="checkbox"/>	30x15	L. 2000	fer plat
MARTELÉ	ART. TCMA30X20	<input type="checkbox"/>	30x20	L. 2000	fer plat
MARTELÉ	ART. TCMA35X15	<input type="checkbox"/>	35x15	L. 2000	fer plat
MARTELÉ	ART. TCMA35X20	<input type="checkbox"/>	35x20	L. 2000	fer plat
MARTELÉ	ART. TCMA40X15	<input type="checkbox"/>	40x15	L. 2000	fer plat
MARTELÉ	ART. TCMA40X20	<input type="checkbox"/>	40x20	L. 2000	fer plat

CINTRES EN FER PLAT LISSES POUR PORTAIL

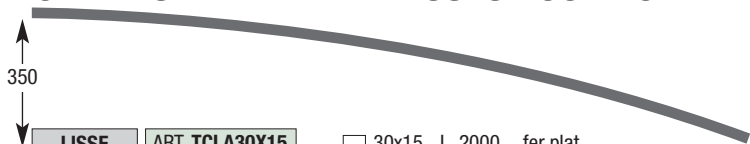

LISSE	ART. TCLA30X15	<input type="checkbox"/>	30x15	L. 2000	fer plat
LISSE	ART. TCLA30X20	<input type="checkbox"/>	30x20	L. 2000	fer plat
LISSE	ART. TCLA35X15	<input type="checkbox"/>	35x15	L. 2000	fer plat
LISSE	ART. TCLA35X20	<input type="checkbox"/>	35x20	L. 2000	fer plat
LISSE	ART. TCLA40X15	<input type="checkbox"/>	40x15	L. 2000	fer plat
LISSE	ART. TCLA40X20	<input type="checkbox"/>	40x20	L. 2000	fer plat

TRAVERSES DROITES POUR PORTAIL

BARRES CARRÉ MARTELÉ - H 2000

MARTELÉ	ART. CM30-2000	<input type="checkbox"/>	30x30	H.2000
MARTELÉ	ART. CM35-2000	<input type="checkbox"/>	35x35	H.2000
MARTELÉ	ART. CM40-2000	<input type="checkbox"/>	40x40	H.2000

BARRES PLAT MARTELÉ - H 2000

MARTELÉ	ART. PM35X15	<input type="checkbox"/>	35x15	H.2000
MARTELÉ	ART. PM35X20	<input type="checkbox"/>	35x20	H.2000
MARTELÉ	ART. PM40X15	<input type="checkbox"/>	40x15	H.2000

BARRES CARRÉ LISSE - H 2000

LISSE	ART. CL30-2000	<input type="checkbox"/>	30x30	H.2000
LISSE	ART. CL35-2000	<input type="checkbox"/>	35x35	H.2000
LISSE	ART. CL40-2000	<input type="checkbox"/>	40x40	H.2000

BARRES PLAT LISSE - H 2000

LISSE	ART. PL35X15	<input type="checkbox"/>	35x15	H.2000
LISSE	ART. PL35X20	<input type="checkbox"/>	35x20	H.2000
LISSE	ART. PL40X15	<input type="checkbox"/>	40x15	H.2000

GONDS REGLABLES

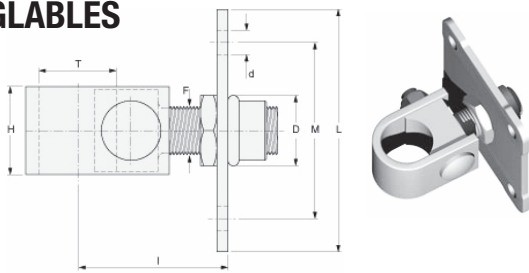

ART.	F	H	T	I	D	d	M	L
GOND3-30	M18	35	30	50-70	28	9	64x64	90x90
GOND3-35	M22	40	35	55-76	35	11	80x80	110x110
GOND3-40	M27	45	40	65-85	46	13	80x80	130x130

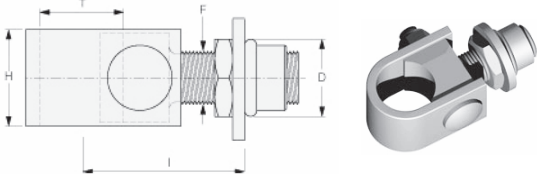

ART.	F	H	T	I	D
GOND2-30	M18	35	30	50-65	28
GOND2-35	M22	40	35	55-76	32
GOND2-40	M27	45	40	65-85	39

AXES A SOUDER

ART.	T	H	A	B	C
AS-30	30	60	30	10	40
AS-35	35	69	35	12	45
AS-40	40	80	40	15	50

GONDS RÉGLABLES AVEC ETRIER A SCELLER

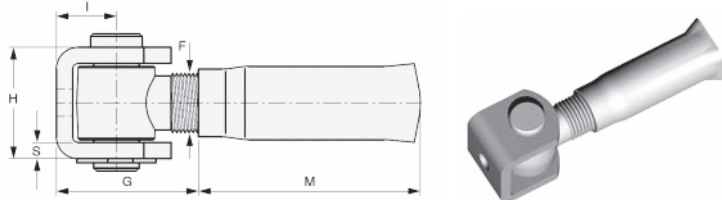

ART.	F	H	S	I	G	M
GOND5-39	M18	39	6	21	min. 40	66
GOND5-41	M22	41	6	23	min. 45	77
GOND5-57	M27	57	8	35	min. 62	90

GONDS RÉGLABLES AVEC ETRIER ET PLAQUE

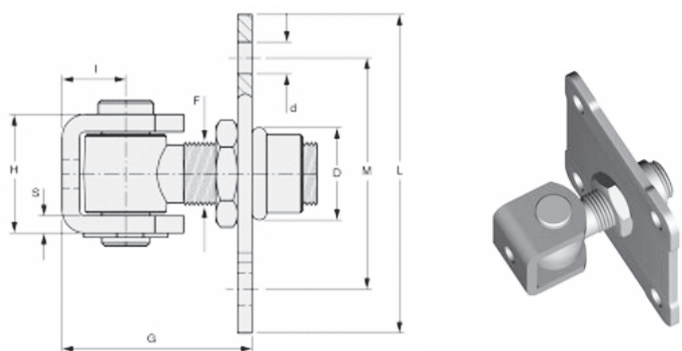

ART.	F	H	S	I	G	D	d	L	M
GOND6-39	M18	39	6	21	50-60	28	9	90x90	64x64
GOND6-41	M22	41	6	23	55-72	32	11	110x110	80x80
GOND6-57	M27	57	8	35	75-85	40	13	130x130	90x90

GONDS RÉGLABLES AVEC PLATINE

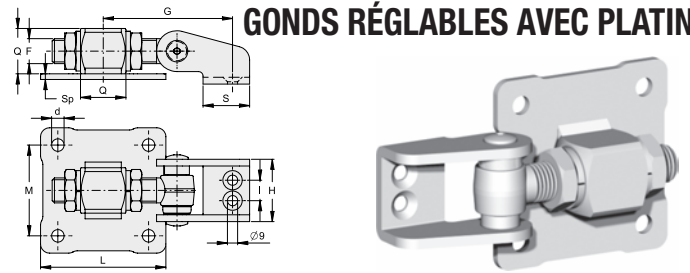

ART.	F	H	S	I	G	Q	L	M	d
236-18P	18	50	38	18	87±102	35	90	64	9
236-22P	22	55	41	18	103±125	40	110	80	11

GOND SUPÉRIEUR RÉGLABLE

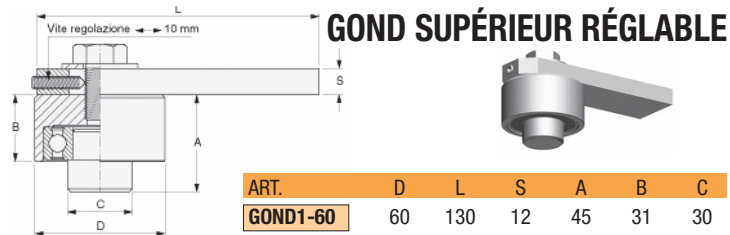

ART.	D	L	S	A	B	C
GOND1-60	60	130	12	45	31	30

PIVOT INFÉRIEUR

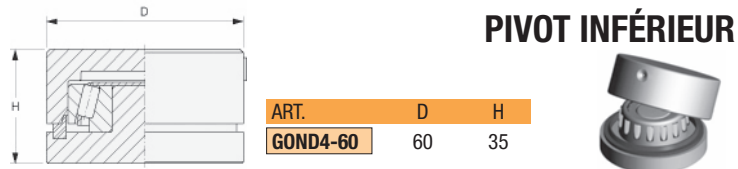

ART.	D	H
GOND4-60	60	35

PIVOT INFÉRIEUR AVEC PLATINE

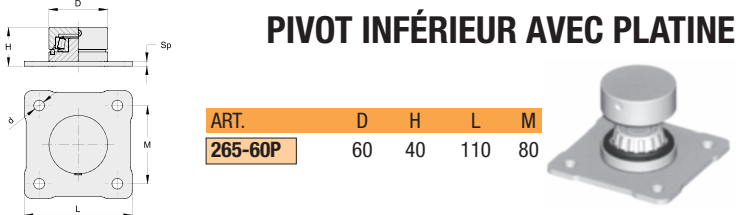

ART.	D	H	L	M
265-60P	60	40	110	80

PIVOT INFÉRIEUR A SOUDER AVEC BILLE

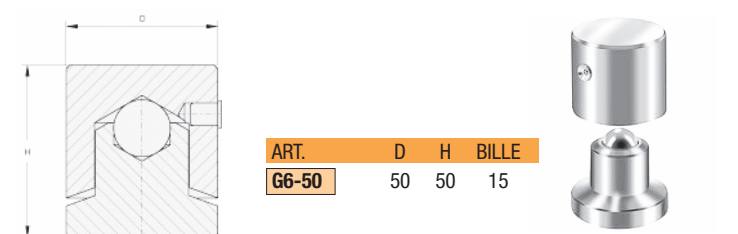

ART.	D	H	BILLE
G6-50	50	50	15

ENSEMBLES PIVOTS À BILLE COMPLETS (haut et bas)

ART. PIV025	pour tube 25 x 25 mm
ART. PIV030	pour tube 30 x 30 mm
ART. PIV035	pour tube 35 x 35 mm
ART. PIV040	pour tube 40 x 40 mm
ART. PIV050	pour tube 50 x 50 mm

ROUE DE COMPENSATION RÉGLABLE

Ø 100 pour vantail de 80 kg

ART. 750100

D	H	B	A
100	35	43	387

Cest	Ccom	L	F	d1	kg.
25	15	106	242	7	80

PAUMELLES

	H
ART. PAUM80	80
ART. PAUM100	100
ART. PAUM120	120
ART. PAUM140	140
ART. PAUM160	160



FIXATIONS RÉGLABLES

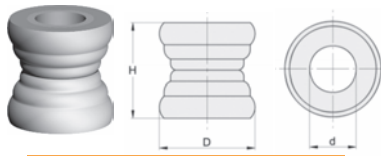

	D	H	d
ART. D02-30-1N	30	23÷33	14.5
ART. D02-30-2N	30	30÷40	14.5

PAUMELLE

pour portillon PISCINE



ART. PAUM
(vendu par paire)

RESSORTS FERME PORTE



ART. 89-200	40 kg
ART. 89-280	60 kg

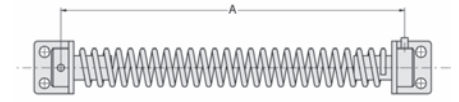

PAUMELLES

	H
ART. PAUM112	112
ART. PAUM133	133
ART. PAUM158	158



PAUMELLES 3D

	Long.	Profilé	axe	Charge/p
ART. S-REG-3D-160	160	20x25	Ø12	75 kg
ART. S-REG-3D-180	180	20x25	Ø12	100 kg

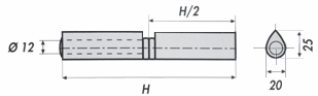

NŒUDS A SOUDER



ART. NŒUD16
PLAT 40x6x100 - Ø 16

ART. NŒUD20
PLAT 50x8x100 - Ø 20

GONDS A SCELLER



ART. GOND16
PLAT 40x6x100 - Ø 16

ART. GOND20
PLAT 50x8x100 - Ø 20

POLYGOND CLIPS



ART. POLYGOND1
Ø 16 - M 12 NOIR



VERROU FORGÉ



NŒUD A SOUDER

PLAT 40 x 6 - Ø 16

ART. NŒUD16



NŒUD A SOUDER

PLAT 40 x 6 - Ø 16

ART. NŒUD16

ART. VERROU Ø16

VERROU A VISSER

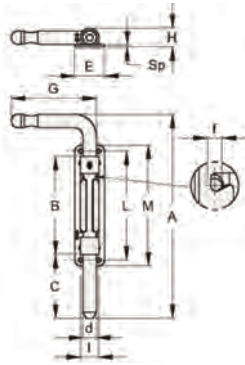

	d	A	B	E	G
ART. 50EL-16	16	440	115	47	100

CAVALIERS

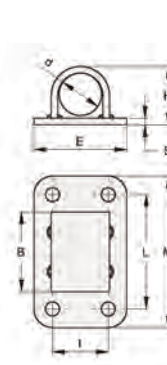

	d	B	E	H	I	L	M	Sp
ART. 53E-16	16	30	47	22,5	33	43	57	2,5

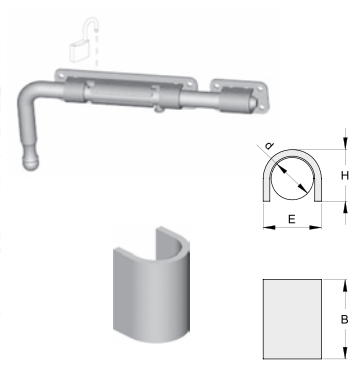

	d	B	E	H
ART. 53-16	16	30	22	20

GALOCHES



ART. GAL1 Ø 100



ART. GAL2 □ 60 X 6

EMBOUS PLASTIQUE POUR TUBE SERRURIER

épaisseur 1 à 2,5 mm

ART. CP30P	30 x 30
ART. CP40P	40 x 40
ART. CP60P	60 x 60
ART. CP80P	80 x 80
ART. CP100P	100 x 100
ART. CP120P	120 x 120

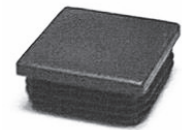

CHAPEAUX DE PILIERS carrés avec bords

	L
ART. CP40L	40
ART. CP50L	50
ART. CP60L	60
ART. CP80L	80
ART. CP100L	100
ART. CP120L	120
ART. CP150L	150

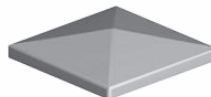
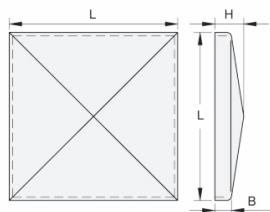

CHAPEAUX DE PILIERS



ART. CHA150
150 x 150



ART. CHA120
120 x 120



ART. CHA100
100 x 100



ART. CHA80
80 x 80

CHAPEAUX DE PILIERS ronds avec bords

	D	B	H
ART. CR42L	42	10	19
ART. CR48L	48	10	20
ART. CR60L	60	10	22
ART. CR76L	76	12	27
ART. CR89L	89	12	25
ART. CR101L	101	12	26
ART. CR114L	114	12	29

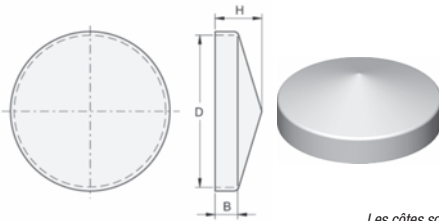

CHAPEAUX DE PILIERS carrés avec bords et boule

	L
ART. CP40LB	40
ART. CP50LB	50
ART. CP60LB	60
ART. CP80LB	80
ART. CP100LB	100

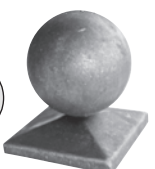
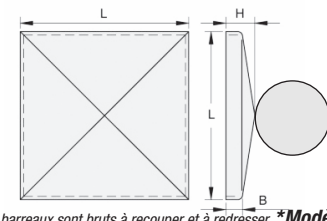

ACCESSOIRES PORTAIL COULISSANT

GUIDE SUPÉRIEUR RÉGLABLE

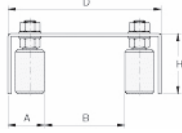
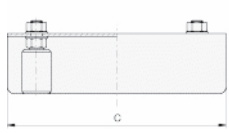

ART. GUIDE-A	
A	40-110
B	0-70
C	220
D	150
H	60



GUIDE SUPÉRIEUR RÉGLABLE

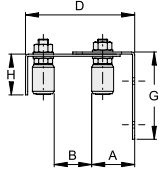
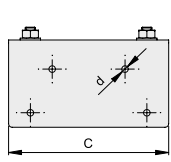

ART. 218LB	
A	50-87
B	60-80
C	350
D	174-207
d	13
G	200
H	82

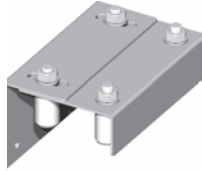

GUIDE SUPÉRIEUR RÉGLABLE AVEC PLAQUE

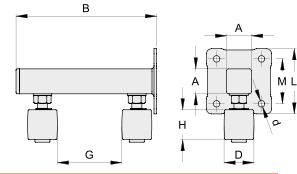
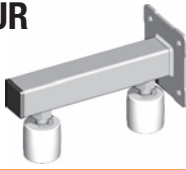

ART. 227.19	A	B	D	H	Gmax	d	L
	50	282	60	60	130	13	130X130

ROUE DE GUIDAGE NYLON

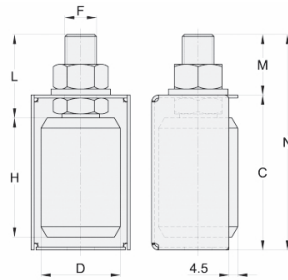

ART. GUIDE-B	
A	50
B	43,5
C	78
M	30,5
N	108,5
D	40
H	60
L	41
F	M16



AVEC PROTECTION

ART. GUIDE-C	
D	40
H	60
L	41
F	M16



ROUE DE GUIDAGE NYLON

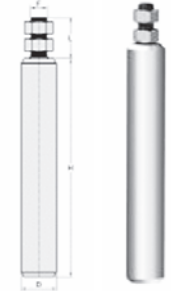

ART. GUIDE-D	
D	40
H	250
L	42
F	16

ROUE DE GUIDAGE NYLON AVEC SUPPORT

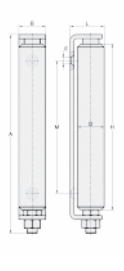

ART. GUIDE-E	
D	40
H	250
A	299
B	40
L	51
M	200
d	9



GUIDE DE SURETÉ

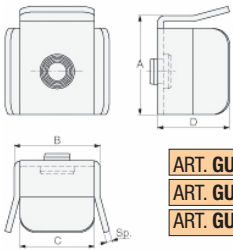

	A	B	C	D
ART. GUIDE59	59	50	44	45
ART. GUIDE69	69	60	54	50
ART. GUIDE79	79	70	64	60

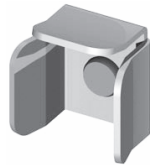

ARRÊT AMORTISSEUR GALVANISÉ

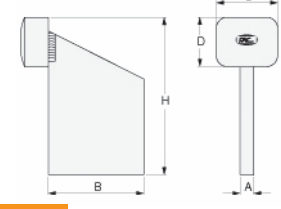

ART. ARRÊT	
A	10
B	70
C	45
D	36
H	115



GALET A GORGE EN V

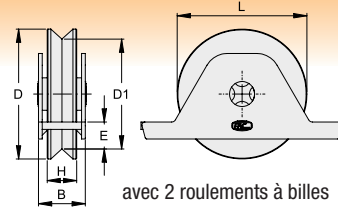

ART. G120		ART. G90		1 roulement
D	120		90	
D1	103		75	
B	38		33	
H	25		20	
E	23		17	
L	130		97	
KG	400		200	



GALET A GORGE DEMI RONDE

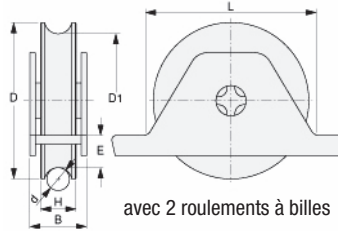

ART. G120A		ART. G90A		1 roulement
D	120		90	
D1	103		73,5	
B	38		33	
H	25		21	
E	23		17	
L	130		97	
KG	400		200	



GALET A GORGE EN V A VISSER

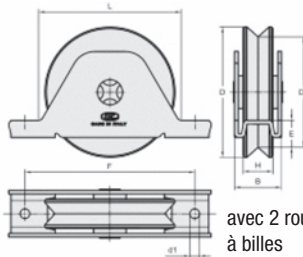

ART. G120C	
D	120
D1	103
B	38
H	25
E	23
L	130
F	150
KG	400



GALET A GORGE DEMI RONDE A VISSER

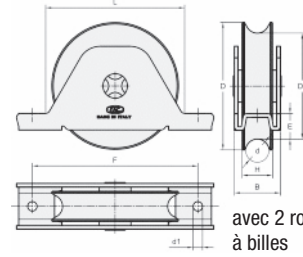

ART. G120D	
D	120
D1	101
d	20
B	38
H	25
E	22
L	130
F	150
KG	400



RAIL A VISSER DEMI ROND

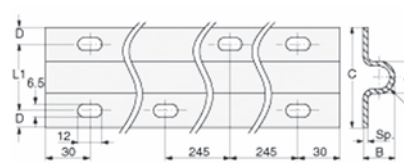

ART. RAILA	
A	20
B	16
C	55
D	8,7
L1	37,5
R	10
Sp	3,5
L(m)	3



RAIL A VISSER EN V

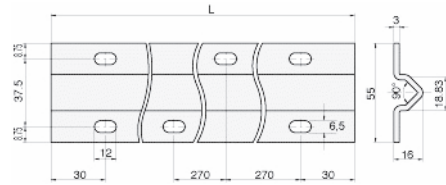

ART. RAILB	
L(m)	3

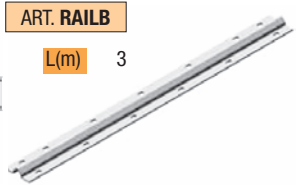

RAIL A SCELLER DEMI ROND

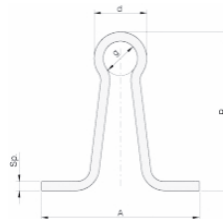

ART. RAILC	
A	60
B	60
d	20
g	13
R	10
Sp	3,5
L(m)	3



CRÉMAILLÈRE ZINGUÉE

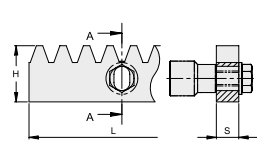

ART. 630-ZF	
L	1 m
H	30
S	12

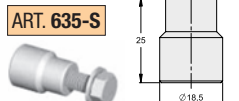
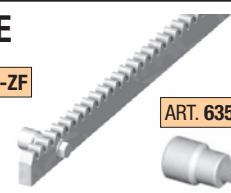

ACCESSOIRES PORTE SUSPENDUE

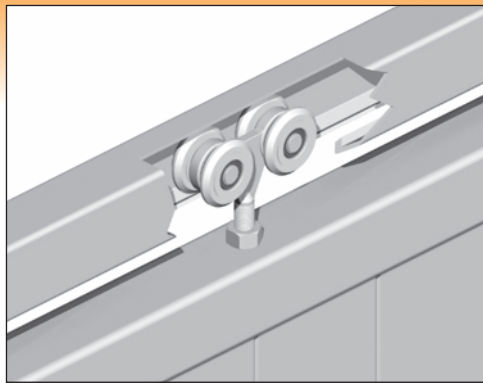

RAIL

	A	B	S	L(m)
ART. P-RF-55	57	67	3	6
ART. P-RF-24	33	31	2	6

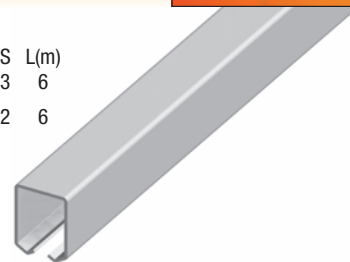
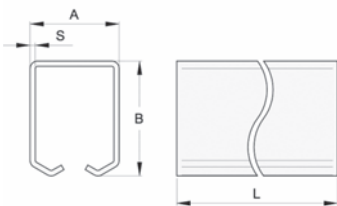

SUPPORT DE RAIL

	C	D	E	G	Sp.
ART. SP55	65,5	86	79	35-52	4
ART. SP24	40,5	48	59	21-41	3

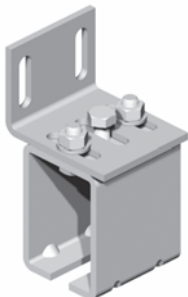
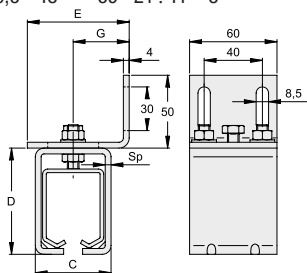

POIGNÉE

	Ø	I	H	L	T
ART. 566	28	280	80	110	345

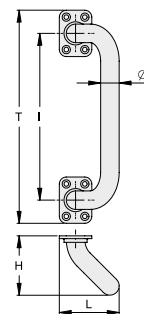

GALET SIMPLE - 24

ART. 24-1	Poids 30 kg
-----------	----------------

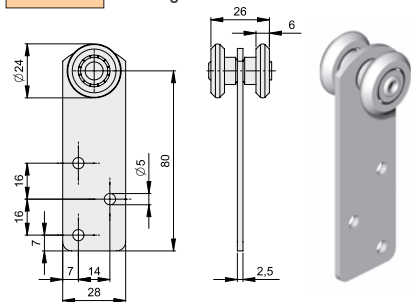

GALET SIMPLE - 24

ART. 24-2	Poids 30 kg
-----------	----------------

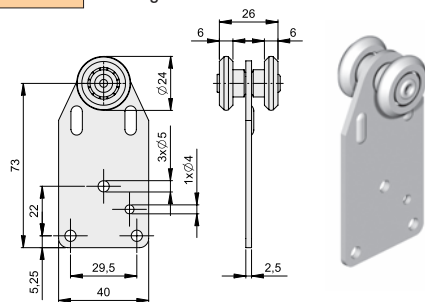

GALET DOUBLE - 24

ART. 24-3	Poids 75 kg
-----------	----------------

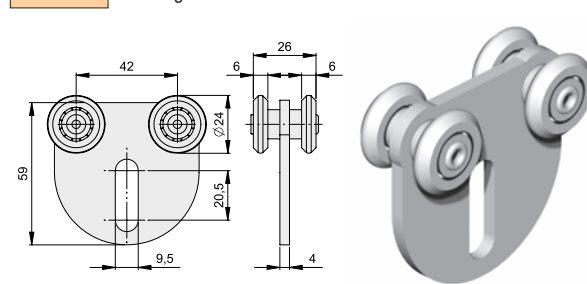

GALET SIMPLE - 55

ART. 2RC55	A	F	H	H1	I	Poids
	55	M20	80	120	30	550 kg

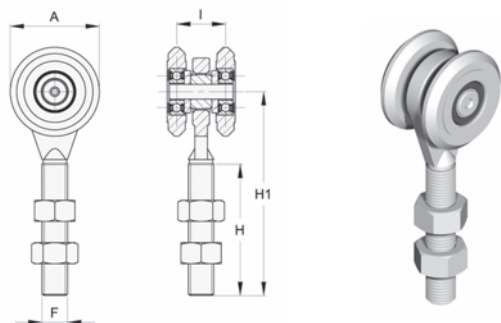

GALET DOUBLE - 55

ART. 4RC55	A	F	H	H1	I	L	Poids
	55	M20	80	130	30	60	1000 kg

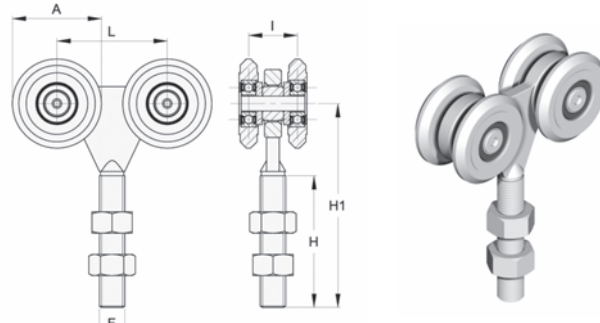

GALET SIMPLE - 24

ART. 2RS	A	F	H	I	Poids
	24	M8	35	20	50 kg

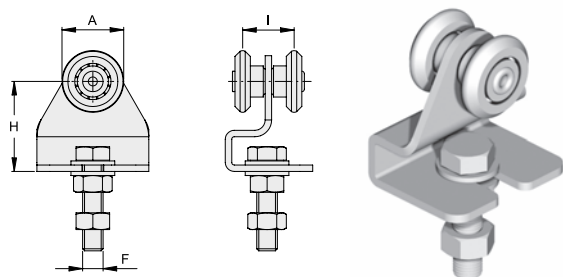

GALET DOUBLE - 24

ART. 4RS	A	F	H	I	L	Poids
	24	M8	35	20	30	75 kg

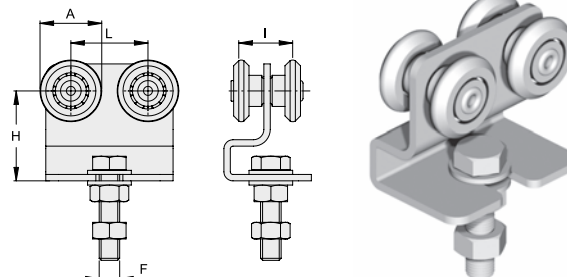

SÉRIE 2000 - portail jusqu'à 9 m - 850 kg maxi

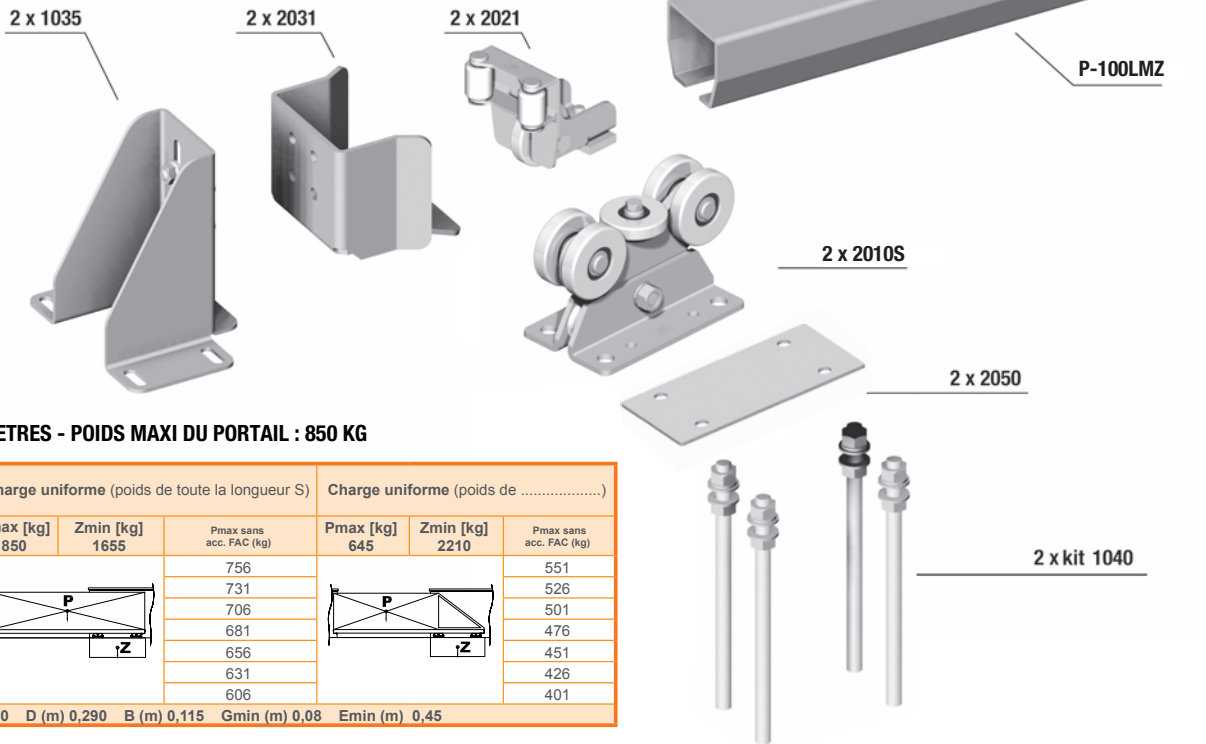

SERIE 2000 PORTAIL JUSQU'A 9 METRES - POIDS MAXI DU PORTAIL : 850 KG

Dimensions			TxUxH min (m)	Charge uniforme (poids de toute la longueur S)			Charge uniforme (poids de)		
A (m)	C (m)	S (m)		Pmax [kg]	Zmin [kg]	Pmax sans acc. FAC (kg)	Pmax [kg]	Zmin [kg]	Pmax sans acc. FAC (kg)
3	1,20	4,9	2,10x0,80x0,80	850	1655	756	645	2210	551
4	1,60	6,3	2,50x0,80x0,80						
5	2,00	7,7	2,90x0,80x0,80						
6	2,40	9,1	3,30x0,80x0,80	681	656	476	451	426	
7	2,80	10,5	3,70x0,80x0,80	631	606	426	401	401	
8	3,20	11,9	4,10x0,80x0,80						
9	3,60	13,3	4,50x0,80x0,80						

Dati costanti-Fixed data: F1max (kg) 1500 D (m) 0,290 B (m) 0,115 Gmin (m) 0,08 Emin (m) 0,45

GUIDE SÉRIE 2000

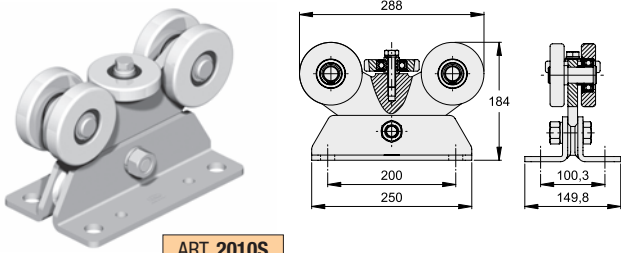

ART. 2010S

PLAQUE FIXATION SÉRIE 2000

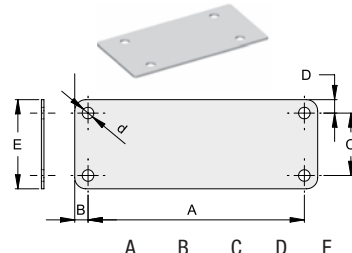

ART. 2050 A 200 B 50 C 100 D 25 E 150 d 18

KIT TIRANTS SÉRIE 2000

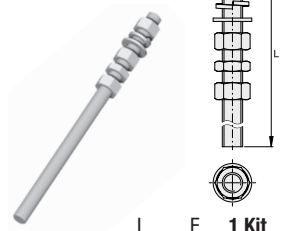

ART. 1040 L 330 F M18 1 Kit 4 p.

ROUE D'EXTREMITÉ SÉRIE 2000

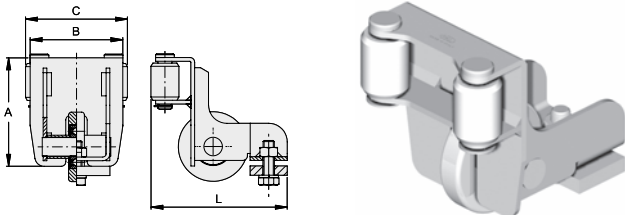

ART. 2021 A 117 B 100 C 110 L 147

RAIL SÉRIE 2000

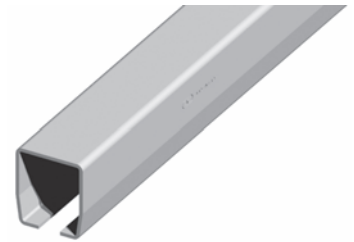

ART. P-100LMZ A 97 B 110 S 5 L(m) 6

SUPPORT SÉRIE 2000

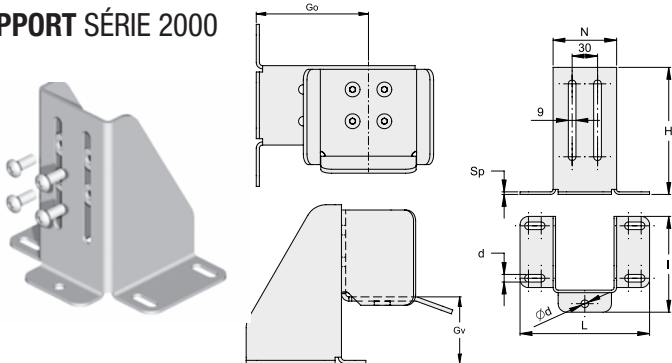

SUPPORT POUR BATTANT FIXATION MURALE OU AU SOL ART. 1035 A 210 B 150 D 177 I 92 d 5 S 11

BATTUE LATÉRALE SÉRIE 2000

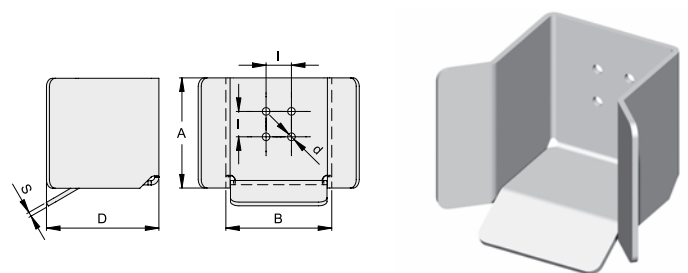

ART. 2031 A 130 B 125 D 133 I 30 d 9 S 5

SÉRIE 3000 - portail jusqu'à 12 m - 1785 kg maxi

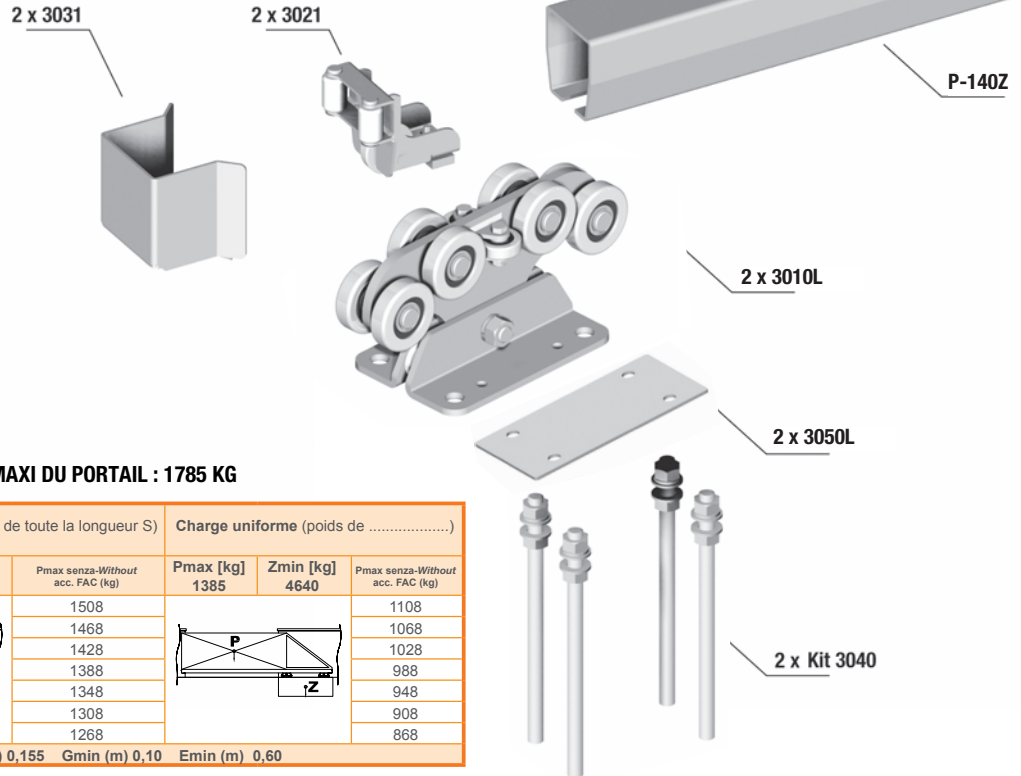

SERIE 3000 PORTAIL JUSQU'A 12 METRES - POIDS MAXI DU PORTAIL : 1785 KG

Dimensions			TxUxH min (m)	Charge uniforme (poids de toute la longueur S)			Charge uniforme (poids de)		
A (m)	C (m)	S (m)		Pmax [kg]	Zmin [kg]	Pmax senza-Without acc. FAC (kg)	Pmax [kg]	Zmin [kg]	Pmax senza-Without acc. FAC (kg)
6	2,4	9,5	3,1x0,60x0,60	1785	3665	1508	1385	4640	1108
7	2,80	10,9	3,5x0,60x0,60			1468			1068
8	3,2	12,3	3,9x0,60x0,60			1428			1028
9	3,60	13,7	4,3x0,60x0,60			1388			988
10	4,00	15,1	4,7x0,60x0,60			1348			948
11	4,40	16,5	5,1x0,60x0,60			1308			908
12	4,80	17,9	5,5x0,60x0,60			1268			868

Dati costanti-Fixed data: F1max (kg) 3200 D (m) 0,40 B (m) 0,155 Gmin (m) 0,10 Emin (m) 0,60

GUIDE SÉRIE 3000

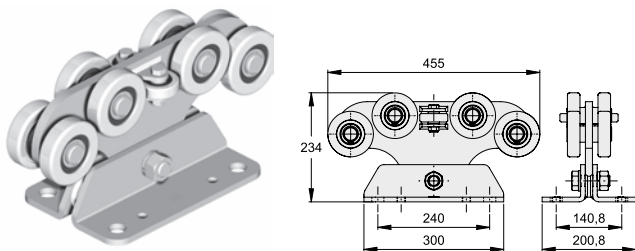

PLAQUE FIXATION SÉRIE 3000

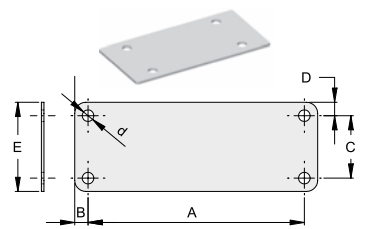

KIT TIRANTS SÉRIE 3000

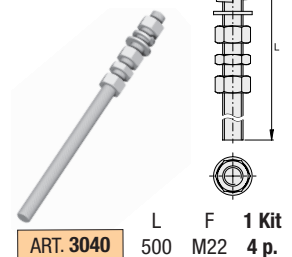

ROUE D'EXTRÉMITÉ SÉRIE 3000

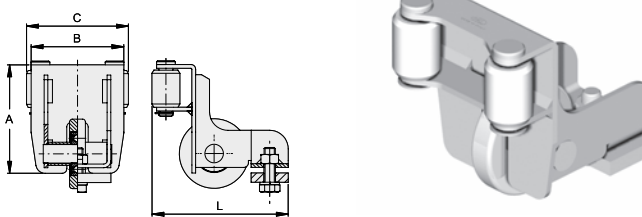

RAIL SÉRIE 3000

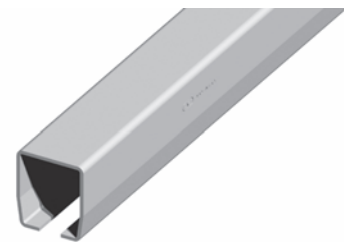

SUPPORT SÉRIE 3000

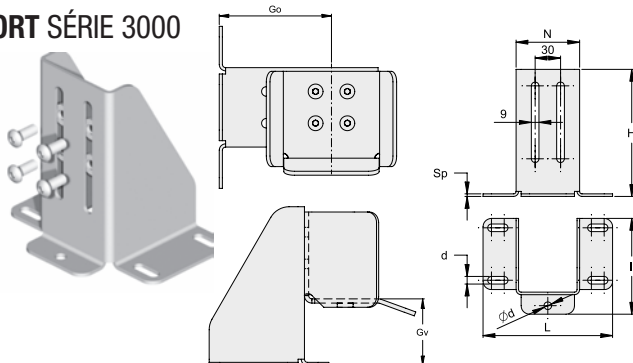

BATTUE LATÉRALE SÉRIE 3000

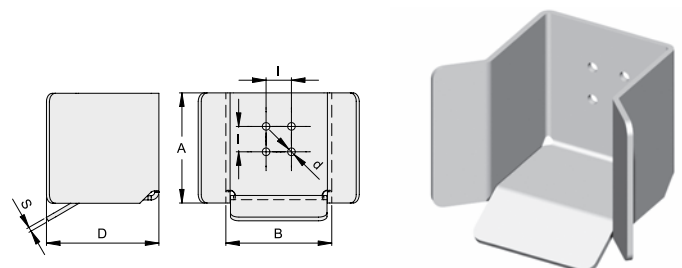

SUPPORT POUR BATTANT
FIXATION MURALE OU AU SOL

A	B	D	I	d	S
210	150	177	92	5	11

A	B	D	I	d	S
166	170	152	30	9	5



SERRURE CISA à fouillot à clé plate VERTICALES



Serrure droite **ART. CISAD**
Serrure gauche **ART. CISAG**

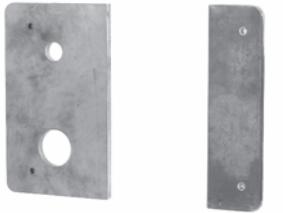

ART. PLAQUES Plaque pour serrure
ART. PLAQUEG Plaque pour gâche

HORIZONTALES



Serrure droite **ART. CISAHD**
Serrure gauche **ART. CISAHG**

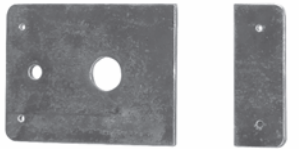

ART. PLAQUEHS Plaque pour serrure
ART. PLAQUEHG Plaque pour gâche

ART. POIGNÉE-6 6
ART. POIGNÉE-7 7



ART. POIGNÉE-8 8

TUBE PRÉPERCÉ 1 POINT

40x40 - H. 2500 pour serrure CISA 1 point



ART. TUBEC

TUBE PRÉPERCÉ GÂCHE 1 PT

40x40 - H. 2500 pour serrure CISA 1 point



ART. TUBEE

SERRURE 1 POINT CISA

encastrée réversible



ART. CISAE1P

PLAT GÂCHE PRÉPERCÉ 1 POINT

Plat 40x10 H. 300 pour serrure CISA 1 point



ART. PLATC

TUBE PRÉPERCÉ 3 POINTS

40x40 - H. 2500 pour serrure CISA 3 points à tête



ART. TUBE B

SERRURE 3 POINTS CISA

encastrée réversible à tête



ART. CISAE3P

TUBE GÂCHE PRÉPERCÉ

40x40 - H. 2500 pour serrure CISA 3 points



ART. TUBE D

PLAT GÂCHE PRÉPERCÉ

40x10 - H. 2500 pour serrure CISA 3 points



ART. PLATB

ENTRÉES DE SERRURE



ART. ES1
L 25 x H 50



ART. ES2
L 40 x H 50



ART. ES4
L 100 x H 160

NŒUDS A SOUDER



ART. NŒUD16
PLAT 40x6x100 - Ø 16

ART. NŒUD20
PLAT 50x8x100 - Ø 20

GONDS A SCELLER



ART. GOND16
PLAT 40x6x100 - Ø 16

ART. GOND20
PLAT 50x8x100 - Ø 20

POLYGOND CLIPS



ART. POLYGOND1
Ø 16 - M 12 NOIR

VERRROU A VISSER

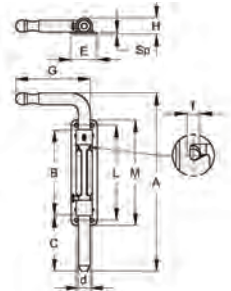

ART. 50EL-16
d A B E G
16 440 115 47 100

TUBE PRÉPERCÉ

40x40 - H. 2500
pour serrure
STREMLER 1 pt.



**SERRURE
STREMLER
1 POINT**

ART.
2260-36-0

ART. TUBEI

**SERRURE
STREMLER
2 POINTS**



ART.
1223-30-0

JEU DE TRINGLES

pour serrure
STREMLER
3 pts / 2 pts



KIT
Tringle Haute
H. 1500
Tringle Basse
H. 1000
Gâche Haute
2 guides

ART.
2837-00-0

TUBE PRÉPERCÉ

40x40 - H. 2500
pour serrure
STREMLER 3 pts.



**SERRURE
STREMLER
3 POINTS
ENCASTRÉE**

ART.
2270-36-0

ART. TUBEH

TUBE PRÉPERCÉ 3 POINTS

40x40 - H. 2500
pour serrure
STREMLER
à tête



**SERRURE
STREMLER
3 POINTS
À TÊTIÈRE**



ART.
6370-36-1

ART. TUBE G

PAUMELLE TRUCLOSE automatique



ART. PAUM
(vendu par paire)

TUBE PRÉPERCÉ

40x40
H. 1500
pour serrure
piscine



ART. TUBE A

TUBE GÂCHE PRÉPERCÉ

40x40
H. 1500
pour serrure
piscine



ART. TUBE K

**SERRURE
STREMLER
pour portillon
de piscine**



ART. SERPISCINE

PLAT PRÉPERCÉ



Plat 40 x 10
H. 300

ART. PLATA

SERRURE À CROCHET AVEC CYLINDRE ET CLÉS

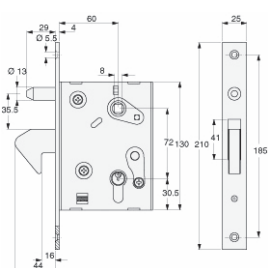

ART. SERCROCHETA

COFFRE COUVRE SERRURE

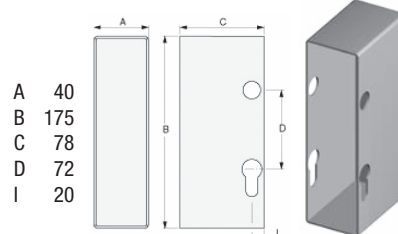

A 40
B 175
C 78
D 72
I 20

ART. COFFREA40

GÂCHES FERMÉES POUR SERRURE À CROCHET

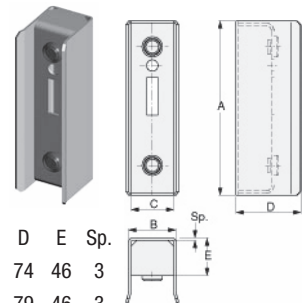

ART.	A	B	C	D	E	Sp.
GÂCHEA48	216	48	42	74	46	3
GÂCHEA58	216	58	52	79	46	3

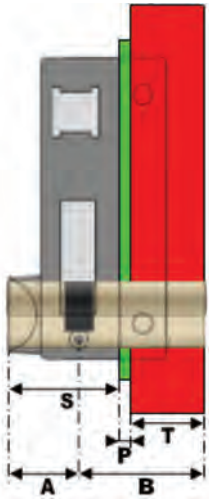

Choisir un cylindre

A : cote A du cylindre

B : cote B du cylindre

S : épaisseur de la serrure

P : épaisseur de la plaque

T : épaisseur du tube d'encadrement de porte



GAUCHE

ART. PE-VG

□ 7 - 75x130 - S.46
applique-euro-A.30



DROITE

ART. PE-VD

□ 7 - 75x130 - S.46
applique-euro-A.30



LISSE

ART. ESV5

Pour (PE-VG/D) P.5



LISSE

ART. EGV5

Pour (PE-VG/D) P.5



GAUCHE

ART. PE-HG

□ 7 - 140x88 - S.46
applique-euro-A.30



DROITE

ART. PE-HD

□ 7 - 140x88 - S.46
applique-euro-A.30

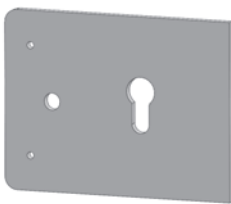

LISSE

ART. ESH6

pour (PE-HG/D) P.5



LISSE

ART. EGH6

pour (PE-HG/D) P.5



ART. POIGNEED

□ 6 - L. 85 - 2 portées



ART. POIGNEEC

□ 6 - L. 85 - 0 portée



ART. POIGNEEA-6

□ 6 - L. 85 - 2 portées



ART. FOURREAU6-7

□ 6-7 - L. 17

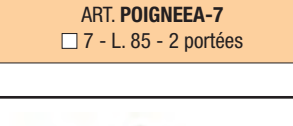

ART. POIGNEEA-7

□ 7 - L. 85 - 2 portées

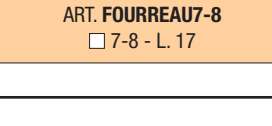

ART. FOURREAU7-8

□ 7-8 - L. 17



Cylindre profil européen

Cylindre européen VARIES

(Une seule porte sera ouverte par une seule clé)

ART. CYLINDREA-30x30
30x30 européen
3 clés



ART. CYLINDREA-30x70
30x70 européen
3 clés



ART. CYLINDREA-30x40
30x40 européen
3 clés



ART. CYLINDREA-30x80
30x80 européen
3 clés



ART. CYLINDREA-30x50
30x50 européen
3 clés



ART. CYLINDREA-40x40
40x40 européen
3 clés



ART. CYLINDREA-30x60
30x60 européen
3 clés



ART. CYLINDREA-40x50
40x50 européen
3 clés



Cylindre européen S'ENTROUVANT

(Plusieurs portes seront ouvertes par les mêmes clés)

ART. CYLINDREB-30x30
30x30 européen
3 clés s'entrouvant



ART. CYLINDREB-30x60
30x60 européen
3 clés s'entrouvant

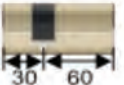

ART. CYLINDREB-30x40
30x40 européen
3 clés s'entrouvant



ART. CYLINDREB-30x70
30x70 européen
3 clés s'entrouvant



ART. CYLINDREB-30x50
30x50 européen
3 clés s'entrouvant



ART. CYLINDREB-40x40
40x40 européen
3 clés s'entrouvant



FEUILLES FORGÉES



exemple



ART. SERPENTIN
Ø 3 mm



ART. FV1
138 x 125
ép. 3 mm



ART. FV2
90 x 83
ép. 3 mm



ART. GR9
150 x 55

*



ART. GR10
165 x 60

*



ART. GR11
200 x 65

*

FLEURS ET FEUILLES ESTAMPÉES



ART. ROA1
Ø 55 - ép. 8 mm



ART. ROA2
Ø 90 - ép. 8 mm



ART. 31-001
Ø 95 - ép. 5 mm



ART. 033-01-000
Ø 70 - ép. 3 mm



ART. 034-01-000
Ø 95 - H.47 ép.3



ART. ROSE
Ø 60 - H.47 mm



ART. 10-01
Ø 125 - ép. 13 mm



ART. 10-02
Ø 90 - ép. 13 mm



ART. 10-03
Ø 50 - ép. 6 mm



ART. BE14.108
Ø 38 x H 7 mm



ART. RL-02
Ø 90



ART. ROSEA
150 x 300 mm



ART. BE14.084.01
80 x 70
ép. 2 mm



ART. R35
300 x 150



ART. 035-01-000
300 x 40
ép. 2 mm



ART. FA1
300 x 67
ép. 3 mm



ART. F13
100 x 30



ART. F12
100 x 30

ART. F13-2
115 x 50

ART. F12-2
115 x 50



ART. BE14214
235 x 130



ART. BE14.215
235 x 130



ART. F13-3
155 x 60

ART. F13-4
180 x 65



ART. F12-3
155 x 60

ART. F12-4
180 x 65



ART. BE14.026.1
ép. 2 mm - H 50 - Ø 75



ART. FA5
65 x 75



ART. BE14.087.04
270 x 60 - ép. 2 mm



ART. 215-05-000
H 90 - □ 17x7



ART. 214-05-000
H 90 - □ 17x7



ART. 271-02-000
160 x 75



ART. 272-02-000
160 x 75

ART. IMP1
160 x 950
□ 14 - □ 14x6

ART. IMP2
160 x 950
□ 14 - □ 14x6

ART. IMP3
180 x 950
□ 14 - □ 14x6

ART. IMP4
180 x 950
□ 12 - □ 12x6

ART. IMP12
230 x 950
□ 12 - □ 12x6

MARTELÉE
ART. ROSAE1
H 520 x L 420
□ 12

MARTELÉE
ART. ROSAE2
H 710 x L 710
□ 12

ART. PAN1
860 x 350 - □ 12 X 6

ART. PANGR2
800 x 165 - Ø 14

ART. PANGR3
800 x 165 - Ø 14

ART. IMP20
720 x 340 - □ 20 x 6

ART. IMP21
720 x 340 - □ 20 x 6

ART. FL21
180 x 60
Ø 29

ART. FL22
205 x 65
Ø 35

ART. 26-2
100 x 210

ART. 26-3
90x90 - ép. 14

ART. FPE20
885 x 260 - Ø 12

ART. GR9
150 x 55

ART. GR5
80 x 60

CLOUS ET RIVETS

RIVETS

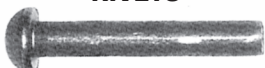

- ART. RV6-20** h 20 mm - Ø 6 mm
- ART. RV6-40** h 40 mm - Ø 6 mm
- ART. RV8-20** h 20 mm - Ø 8 mm
- ART. RV8-40** h 40 mm - Ø 8 mm

CLOU ACIER A SOUDER SUR TÔLE

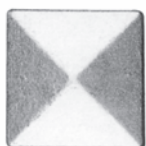

ART. CLOU60
H 23 - □ 60 mm

CLOUS ACIER A PLANTER



- CH10-18** tête Ø 18 mm
- CH20-22** tête Ø 22 mm
- CH20-30** tête Ø 30 mm
- CH30-15** tête □ 15 mm
- CH30-20** tête □ 20 mm
- CH30-28** tête □ 28 mm

PLATINES DE FIXATION



LISSE

ART. PLO80X80C16-6
H. 80 x L. 80
EP. 6 3Trous Ø 6
PASSAGE 16,5



LISSE

ART. PLC60X60C25-6
H. 60 x L. 60
EP. 6 4Trous Ø 8,5
PASSAGE 26



LISSE

ART. PLC60X60C30-6
H. 60 x L. 60
EP. 6 4Trous Ø 8,5
PASSAGE 31



LISSE

ART. PLR60R25-6
L. Ø 60 - EP. 6
4Trous Ø 8,5
PASSAGE 26



LISSE

ART. PLR60R30-6
L. Ø 60 - EP. 6
4Trous Ø 8,5
PASSAGE 31

PLATINES DE FIXATION RONDES



LISSE

ART. PLR200-10
L. Ø 200 - EP. 10
4Trous Ø 15



LISSE

ART. PLR150-8
L. Ø 150 - EP. 8
4Trous Ø 13



LISSE

ART. PLR120-8
L. Ø 120 - EP. 8
4Trous Ø 11



LISSE

ART. PLR100-8
L. Ø 100 - EP. 8
4Trous Ø 9



LISSE

ART. PLR80-6
L. Ø 80 - EP. 6
4Trous Ø 9



LISSE

ART. PLR60-6
L. Ø 60 - EP. 6
4Trous Ø 8,5

PLATINES DE FIXATION CARREES



LISSE

ART. PLC200X200-10
H. 200 x L. 200
EP. 10 4Trous Ø 15



LISSE

ART. PLC150X150-8
H. 150 x L. 150
EP. 8 4Trous Ø 13



LISSE

ART. PLC120X120-8
H. 120 x L. 120
EP. 8 4Trous Ø 11



LISSE

ART. PLC100X100-8
H. 100 x L. 100
EP. 8 4Trous Ø 9



LISSE

ART. PLC80X80-6
H. 80 x L. 80
EP. 6 4Trous Ø 9



LISSE

ART. PLC60X60-6
H. 60 x L. 60
EP. 6 4Trous Ø 8,5

SUPPORTS DE MAINS COURANTES A VISSER



LISSE

ART. SUPP37SP
Øbase.63 x L.80
2Trous Ø 6 ■18
base 4Trous Ø6

LISSE

ART. SUPP37SR
Øbase.63 x L.70
■18
base 4Trous Ø6

LISSE

ART. SUPP37SC
Øbase.63 x L.70
■14
base 4Trous Ø6

MARTELE

ART. SUP1
Hbase.95 x L.102
■14
base 2Trous Ø6

LISSE

ART. BSSMC5
Hbase.150 x L.85
■14
base 2Trous Ø6,5

LISSE

ART. BSSMC3
Øbase.85 x L. 85
■14
base 3Trous Ø8,5

MARTELE

ART. SUP01
Hbase.80 x L.80
2Trous Ø 6 ■14
base 3Trous Ø6



NOUVEAU

ART. FERLUX16-2L5
TEINTE COLOMBE
Cod. 298 - 2,5 litres

ART. FERLUX11-2L5
TEINTE ROUILLE
Cod. 298 - 2,5 litres

ART. FERLUX05-2L5
TEINTE OR
Cod. 298 - 2,5 litres

ART. FERLUX03-2L5
TEINTE FER
Cod. 298 - 2,5 litres

ART. FERLUX04-2L5
TEINTE ANTHRACITE
Cod. 298 - 2,5 litres



NOUVEAU

ART. FERLUX16-0L5
TEINTE COLOMBE
Cod. 298 - 500 ml

ART. FERLUX11-0L5
TEINTE ROUILLE
Cod. 298 - 500 ml

ART. FERLUX05-0L5
TEINTE OR
Cod. 298 - 500 ml

ART. FERLUX03-0L5
TEINTE FER
Cod. 298 - 500 ml

ART. FERLUX04-0L5
TEINTE ANTHRACITE
Cod. 298 - 500 ml

NOUVEAU



ART. NITROGRIS-25L
TEINTE GRIS
Cod. 035 - 25 litres

NOUVEAU



ART. NITROGRIS-2L5
TEINTE GRIS
Cod. 035 - 2,5 litres

NOUVEAU



ART. DILNITRO-5L
DILUANT NITRIQUE
5 litres

BRUNISSEUR DE METAUX

NOUVEAU



ART. HEMA1L

NOUVEAU



ART. RUSTOL20L

NOUVEAU



ART. RUSTOL500mL

RUSTOL OWATROL INCOLORE



ART. RUSTOL1L



ART. RUSTOL5L

CHIFFRES ET LETTRES - Épaisseur 8 mm

1 2 3 4 5 6 7 8 9 0

ART. CHIFFRE1 H 100 ART. CHIFFRE2 H 100 ART. CHIFFRE3 H 100 ART. CHIFFRE4 H 100 ART. CHIFFRE5 H 100 ART. CHIFFRE6 H 100 ART. CHIFFRE7 H 100 ART. CHIFFRE8 H 100 ART. CHIFFRE9 H 100 ART. CHIFFRE0 H 100

A B C D E F

ART. INITIALEA H. 200 - ép. 8 mm ART. INITIALEB H. 200 - ép. 8 mm ART. INITIALEC H. 200 - ép. 8 mm ART. INITIALED H. 200 - ép. 8 mm ART. INITIALEE H. 200 - ép. 8 mm ART. INITIALEF H. 200 - ép. 8 mm

G H I J K L

ART. INITIALEG H. 200 - ép. 8 mm ART. INITIALEH H. 200 - ép. 8 mm ART. INITIALEI H. 200 - ép. 8 mm ART. INITIALEJ H. 200 - ép. 8 mm ART. INITIALEK H. 200 - ép. 8 mm ART. INITIALEL H. 200 - ép. 8 mm

M N O P Q R

ART. INITIALEM H. 200 - ép. 8 mm ART. INITIALEN H. 200 - ép. 8 mm ART. INITIALEO H. 200 - ép. 8 mm ART. INITIALEP H. 200 - ép. 8 mm ART. INITIALEQ H. 200 - ép. 8 mm ART. INITIALER H. 200 - ép. 8 mm

S T U V W X

ART. INITIALES H. 200 - ép. 8 mm ART. INITIALET H. 200 - ép. 8 mm ART. INITIALEU H. 200 - ép. 8 mm ART. INITIALEV H. 200 - ép. 8 mm ART. INITIALEW H. 200 - ép. 8 mm ART. INITIALEX H. 200 - ép. 8 mm

Y Z  **NOUVEAU** Bis *Villa Maryac*

ART. INITIALEY H. 200 - ép. 8 mm ART. INITIALEZ H. 200 - ép. 8 mm ART. LOSANGE 135 x 135 - ép. 6 mm ART. BIS1 H. 120 - ép. 8 mm

NOM DE VILLA SUR COMMANDE

ART. LETTRES
majuscule H. 120
minuscule H. 36
ép. 8 mm

GIROUETTE



ART. COQ

NOUVEAU

FRISE GRECQUE



ART. FGL100X917
H 100 mm - L. 917 mm - ép. 12 mm

ART. FGL84X960
H 84 mm - L. 960 mm - ép. 6 mm

ART. FGL45X972
H 45 mm - L. 972 mm - ép. 2mm



CHARBON
DE
FORGE
25Kg

ART. CHARBON

ACIER A SOUDER



ART. G6-30
H.80 - Ø 69
Trou Ø 30,5



ART. G6-30D
H.52 - Ø 69
Trou Ø 30,5



ART. G4-18
H.80 - Ø 50
Trou Ø 18,5



ART. G4-18D
H.47 - Ø 50
Trou Ø 18,5



ART. G4-14
H.67 Ø 40
Trou Ø 14,5



ART. G4-14D
H.39 - Ø 40
Trou Ø 14,5



ART. G4-20
H.80 - Ø 50
Trou Ø 20,5



ART. G4-20D
H.47 - Ø 50
Trou Ø 20,5



ART. G4-16
H.67 Ø 40
Trou Ø 16,5



ART. G4-16D
H.39 - Ø 40
Trou Ø 16,5



ART. G4-14C
H.67 Ø 45
Trou □ 14,5

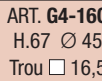

ART. G4-16C
H.67 Ø 45
Trou □ 16,5

ARTICLES FONTE



ART. G9-16
H.128 - L.38
Trou Ø 16,5



ART. G9-16D
H.70 - L.38
Trou Ø 16,5



ART. G10-16
H.40 - L.40
Trou Ø 16,5

ACIER A SOUDER



ART. G1-16
H.22 - Ø 40 - Trou Ø 16,5



ART. G11-14
H.22 - Ø 37 - Trou Ø 14,5



ART. G7-14C
H.22 - L.39 - Trou □ 14,5

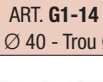

ART. G1-14
H.22 - Ø 40 - Trou Ø 14,5

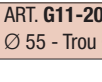

ART. G11-20
H.35 - Ø 55 - Trou Ø 20,5

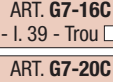

ART. G7-16C
H.22 - L.39 - Trou □ 16,5



ART. G2-14C
□ 40 x 20



ART. G2-14C
H.22 - Ø 40 - Trou □ 14,5

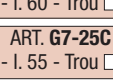

ART. G7-20C
H.38 - L.60 - Trou □ 20,5

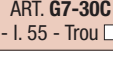

ART. G7-25C
H.38 - L.55 - Trou □ 25,5



ART. G7-30C
H.38 - L.55 - Trou □ 30,5

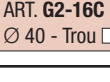

ART. G2-14C
H.22 - Ø 40 - Trou □ 14,5



ART. G2-16C
H.22 - Ø 40 - Trou □ 16,5

ACIER A SOUDER



ART. G8-14
H.135 - larg. 36
Trou Ø 14,5



ART. G8-16
H.135 - larg. 36
Trou Ø 16,5



ART. G8-14D
H.75 - larg. 36
Trou Ø 14,5

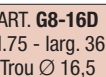

ART. G8-16D
H.75 - larg. 36
Trou Ø 16,5



ART. G5-14
H.120 - L.28
Trou Ø 14,5



ART. G5-14D
H.64 - L.28
Trou Ø 14,5



ART. G5-16
H.120 - L.28
Trou Ø 16,5



ART. G5-16D
H.64 - L.28
Trou Ø 16,5

ACIER TOURNE AVEC VIS POINTEAU



ART. F62-416
H.17 - L.28
Trou Ø 14



ART. F62-425
H.44 - L.30
Trou Ø 14



ART. F62-419
H.14 - L.25
Trou Ø 14



ART. F62-422
H.30 - L.30
Trou Ø 14



ART. BSEG114
H.24 - L.33
Trou Ø 14



ART. BSEG614
H.65 - L.36
Trou Ø 14



ART. BSEG514
H.70 - L.31
Trou Ø 14



ART. BSEG714
H.135 - L.33
Trou Ø 14

ART. F62-417
H.20 - L.32
Trou Ø 16

ART. F62-426
H.44 - L.30
Trou Ø 16

ART. F62-420
H.14 - L.25
Trou Ø 16

ART. F62-423
H.30 - L.30
Trou Ø 16

ART. BSEG116
H.27 - L.37
Trou Ø 16

ART. BSEG616
H.69 - L.38
Trou Ø 16

ART. BSEG516
H.80 - L.35
Trou Ø 16

ART. BSEG716
H.150 - L.37
Trou Ø 16

ART. F62-418
H.22 - L.36
Trou Ø 18

ART. BSEG118
H.30 - L.41
Trou Ø 18

ART. BSEG618
H.74 - L.43
Trou Ø 18

ART. BSEG518
H.90 - L.39
Trou Ø 18

ART. BSEG718
H.170 - L.41
Trou Ø 18

GARNITURE DE BARREAU

Modèle déposé



ART. GV1
H.130 - L.130
Trou Ø 14

PLATINES CACHE SCELLEMENT



ART. P50-40
80 x 80
trou □ 40,5



ART. P50-30
60 x 60
trou □ 30,5



ART. P50-25
60 x 60
trou □ 25,5



ART. P50-20
50 x 50
trou □ 20,5



ART. P50-18
50 x 50
trou □ 18,5



ART. P50-16
40 x 40
trou □ 16,5



ART. P50-14
40 x 40
trou □ 14,5



ART. P35-25
100 x 100
trou □ 25,5



ART. P35-30
100 x 100
trou □ 30,5



ART. P60-65
base Ø 120
trou Ø 65



ART. P60
base Ø 80



ART. P60-30
base Ø 60
trou Ø 30,5



ART. P60-25
base Ø 60
trou Ø 25,5



ART. P60-20
base Ø 50
trou Ø 20,5



ART. P60-18
base Ø 50
trou Ø 18,5



ART. P60-16
base Ø 40
trou Ø 16,5



ART. P60-14
base Ø 40
trou Ø 14,5



ART. P37S
Ø 63
trou Ø 10

FLÈCHES ESTAMPÉES ACIER



ART. P41
H. 133 - □ 20

Modèle déposé



ART. P17A
H. 190 - Ø 20



ART. P17B
H. 155 - Ø 16



ART. P17C
H. 130 - Ø 12



ART. P17D
H. 155 - Ø 16



ART. P17E
H. 130 - Ø 12



ART. P17F
H. 135 - Ø 26,5



ART. P19A
H. 190 - Ø 20



ART. P19B
H. 155 - Ø 16



ART. P19C
H. 125 - Ø 12



ART. P19F
H. 135 - Ø 26,5



ART. BE13.063.01
H. 155 x L. 60
Base □ 14 mm



ART. BE13.110.01
H. 155 x L. 60
Base Ø 24 mm



ART. BE13.110.03
H. 180 x L. 70
Base Ø 27 mm



ART. BE13.110.04
H. 210 x L. 80
Base Ø 30 mm



ART. P33A
H. 200 - Ø 35



ART. P33B
H. 175 - Ø 28



ART. P33C
H. 180 - Ø 30



ART. P8
H. 200 - Ø 20



ART. P9
H. 160 - Ø 16



ART. P10
H. 130 - Ø 13



ART. P31
H. 155 - Ø 16



ART. P32
H. 140 - □ 14



ART. P2
H. 200 - Ø 40



ART. P18A
H. 190 - □ 40



ART. P18B
H. 160 - □ 32



ART. P18C
H. 125 - □ 20



ART. P16A
H. 140 - Ø 38



ART. P16B
H. 125 - Ø 25



ART. P16C
H. 80 - Ø 20



ART. P12
H. 125 - Ø 32



ART. P24
H. 160 - □ 25



ART. P39
H. 140 - □ 14



ART. P40
H. 150 - □ 14



ART. P22
H. 140 - Ø 33



ART. P21
H. 210 - Ø 18



ART. P36
H. 160 - Ø 26



ART. P23
H. 130 - Ø 20



ART. P43
H. 140 - Ø 16



ART. P38
H. 120 - Ø 14

FLÈCHES ESTAMPÉES ACIER



ART. P15-12
H. 70 - □ 12



ART. P11
base Ø 18 - H 125
largeur 40 mm



ART. P38-01
H. 138 x l. 67
Ø 15x7 mm



ART. P42
H. 170 - Ø 50



ART. P50
H. 210 - Ø 32



ART. P25
H. 290 - □ 26



ART. 13-110
H. 238 x l 80
base Ø 50 mm



ART. 14-121
H. 235 - L 80
base Ø 50
filetage M8

LAITON

FLÈCHES FORGÉES ACIER



ART. FL1
H. 240 - Ø 25



ART. FL2
H. 210 - Ø 20

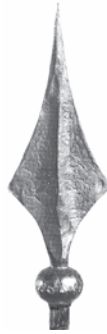

ART. FL3
H. 180 - Ø 16

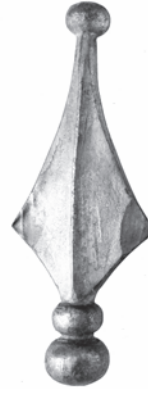

ART. FL4
H. 235 x L 95



ART. FL5
H. 190 x L 70

POMMES DE PIN ESTAMPÉES ACIER



ART. P35E
H 190 mm
base Ø 90 mm



ART. P35D
H 150 mm
base Ø 70 mm



ART. P35B
H 120 mm
base Ø 55 mm



ART. P35A
H 85 mm
base Ø 43 mm



ART. P35C
H 55 mm
base Ø 28 mm

PERCÉ TARAUDÉ M12



ART. P35BM12
h 120 mm
base Ø 55 mm



ART. P35G
H 90 mm
base □ 40 mm



ART. P35F
H 90 mm
base Ø 40 mm



ART. B23
H 90 mm
base Ø 50 mm



ART. B24
H 80 mm
base Ø 28 mm

LAITON



ART. P35BL
H.115 - L. 65 - base Ø 40 mm
taraudage M8

BOULES ESTAMPÉES ACIER



ART. B22A
base Ø 90 - h 140
boule Ø 110 mm



ART. B22B
base Ø 70 - h 125
boule Ø 90 mm



ART. B22C
base Ø 55 - h 100
boule Ø 70 mm



ART. B22D
base Ø 45 - h 85
boule Ø 55 mm

PERCÉ TARAUDÉ M12



ART. B22CM12
base Ø 55 - h 100
boule Ø 70 mm

EMBOUS MONTANTS



ART. B20
H 90 - Ø 50
trou Ø 33



ART. B21
H 90
boule Ø 50 mm



ART. B65E
H 85 - Ø 60 mm

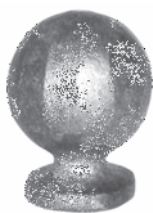

ART. B55E
H 75 - Ø 55 mm



ART. B45E
H 55 - Ø 45 mm



ART. B37E
H 50 - Ø 37 mm



ART. BD20
H. 160 x L 100
Base Ø 70



ART. FL16
H. 105 x L 70
Base Ø 50



ART. FL17
H. 80 x L 50
Base Ø 40



ART. FL18
H. 60 x L 40
Base Ø 30

BOULES FORGÉES ACIER PLEINES



ART. B2
Ø 20



ART. B3
Ø 30



ART. B4
Ø 40



ART. B5
Ø 50



ART. B6
Ø 60

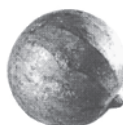

ART. B7
Ø 70

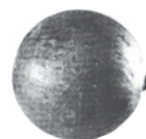

ART. B8
Ø 80

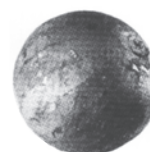

ART. B9
Ø 90

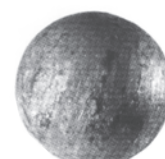

ART. B10
Ø 100

BOULES ESTAMPÉES ACIER PLEINES



ART. B15S
Ø 15



ART. B2S
Ø 20



ART. B25S
Ø 25



ART. B3S
Ø 30



ART. B35S
Ø 35



ART. B4S
Ø 40



ART. B5S
Ø 50



ART. B6S
Ø 60



ART. B7S
Ø 70



ART. B8S
Ø 80



ART. B9S
Ø 90



ART. B10S
Ø 100

BOULES ACIER CREUSES



ART. B4SC
Ø 40



ART. B5SC
Ø 50



ART. B6SC
Ø 60



ART. B7SC
Ø 70



ART. B8SC
Ø 80



ART. B9SC
Ø 90



ART. B10SC
Ø 100



ART. B120SC
Ø 120



ART. B150SC
Ø 150

BOULES RONDLES PERCÉES Ø 6



ART. B10P Ø 10

ART. B12P Ø 12

ART. B14P Ø 14

ART. B16P Ø 16

ART. B18P Ø 18

ART. B20P Ø 20

ART. B22P Ø 22

ART. B25P Ø 25

ART. B30P Ø 30

BOULES MÉPLATES PERCÉES Ø 6



ART. BM16P Ø 16 X 8

ART. BM18P Ø 18 X 11

ART. BM20P Ø 20 X 12

ART. BM22P Ø 22 X 10

ART. BM25P Ø 25 X 16

ART. BM30P Ø 30 X 20

GARNITURES BARREAUX



ART. G21
H.20 - Ø 40
P. Ø 16



ART. G22
H.22 - 35 x 35
P. □ 16



ART. G24
H.42 - Ø 39
P. Ø 16



ART. G25
H.135 - Ø 40
P. Ø 16



ART. AR78360
H135 x Ø 40
P. Ø 16



ART. AR78630
H 260 x Ø 50
P. Ø 25

BOULES DE DÉPART



ART. BL45
H. 68 - Ø 45
base Ø 28 mm
filetage M8



ART. BL75
H.110 - Ø 75
base Ø 40 mm
filetage M12



ART. BL85
H.125 - Ø 85
base Ø 65 mm
filetage M12



ART. BL105G
H.105 - L. 60
base Ø 35 mm
filetage M12



ART. P35BL
H.130 - L. 70
base Ø 40 mm
filetage M8



ART. P35DL
H.160 - L. 80
base Ø 45 mm
filetage M10

SUPPORT BARREAUX



ART. AR34300
130 x 95
Ø 16 mm

PLATINES CACHE SCCELLEMENT

NOUVEAU



ART. P60-30L
passage Ø 30
base Ø 110

ART. P60-40L
passage Ø 40
base Ø 110

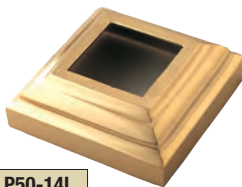

ART. P50-14L
passage □ 14
H25 - 60 x 60

ART. P50-16L
passage □ 16
H25 - 60 x 60

ART. P50-20L
passage □ 20
H25 - 60 x 60

ART. P50-25L
passage □ 25
H25 - 85 x 85

ART. P50-35L
passage □ 35
H25 - 85 x 85

FEUILLES LAITON



ART. F13L 90 x 30
ART. F15L 150 x 50



ART. F12L 90 x 30
ART. F14L 150 x 50

FERS DE LANCE



ART. 14-121
235 x 80 - Ø 50 mm
filetage M8

ROSACES



ART. RL-02
Ø 90



ART. PAL01
380 x 210

MAIN COURANTE ET CROSSES LAITON



ART. MCL15
barre L. 4500
environ

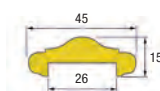

CROSSE
ART. S45L *



CROSSE
ART. C45L *

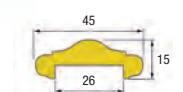



ART. BVA
 boule Ø 100
 base Ø 45



ART. BVO
 boule Ø 100
 base Ø 45

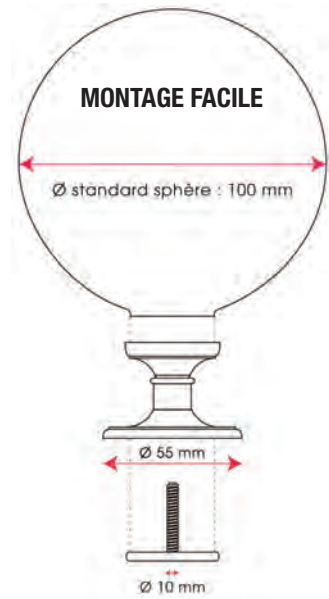

ART. BVP
 boule Ø 100
 base Ø 45



ART. BVV
 boule Ø 100
 base Ø 45



ART. BVM
 boule Ø 100
 base Ø 45



ART. BVZ
 boule Ø 100
 base Ø 45



ART. BVORR
 boule Ø 100
 base Ø 45



ART. BVORW
 boule Ø 100
 base Ø 45



ART. BCBARON
 boule Ø 90
 base Ø 51

Taraudage M12

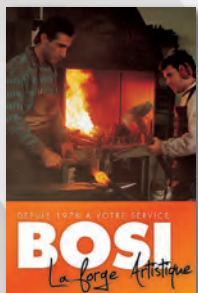

BOSI "La Forge Artistique"

Parc d'activité de la Siagne - Allée Charles Nungesser - 06210 MANDELIEU
Tél. 04 93 47 36 30 - Fax. 04 93 47 38 34

e-mail : ets.bosi@wanadoo.fr